

# SOP Amplification

## Practices and Techniques

This document describes practices and techniques commonly taught by Check and Training staff during crew transition training onto the Boeing 777 at V Australia and elsewhere.

Please note that where possible, references to Boeing and V Australia documentation will be provided against the issues raised in this document. However you will find many items raised here for which no reference is provided – generally this implies the problem is considered basic airmanship or common sense, based on operational experience in the Boeing 777 – or not yet documented.

This document also describes some of the more common errors encountered during training. Some of these errors are not necessarily common, but contain learning points that are considered valuable for all pilots undergoing transition training.

This document includes screen shots and reference text taken from Boeing and V Australia's documentation. These images and text are not necessarily up to date or amended – reference to the original documentation is always mandatory.

Finally, nothing in this document should be considered authoritative over any procedures found in the Boeing Normal Procedures (NP's). The NP's and V Australia A1 document are overriding.

*This document is based on extensive research and operational experience of the Boeing EICAS and ECL found in the 777, in conjunction with documented procedures in the Boeing 777 QRH, FCTM and FCOM. Material incorporated in this guide is taken from all three of the relevant Boeing documents, as well as Boeing publications from issues of Airliner magazine and other sources. Material from the V Australia A1 flight operations manual is also reproduced here.*

*As such the SOP Amplification is to be regarded as secondary in precedence to all these reference texts and should not be actively referred to with respect to operation of the aircraft.*

*Additionally this document incorporates techniques that have been developed and tested in conjunction with Simulator Training but not validated in operation of the aircraft, and must be read with caution.*

<b>1. DOCUMENT SUMMARY.....</b>	<b>7</b>
1.1. Why a Practices and Techniques document?.....	7
1.2. Is this a procedural document – do I have to follow it?.....	7
1.3. Checklist and Checklist Memory Items.....	7
<b>2. GENERAL OBSERVATIONS.....</b>	<b>8</b>
2.1. Recall during Flows.....	8
2.2. ATC make mistakes.....	8
2.3. Checking the next checklist.....	8
2.4. Keep the Lower MFD Clear.....	8
2.5. PF does the Rudder Trim.....	8
2.6. Glass Cockpit Scan.....	9
2.7. Two heads down – in general.....	9
2.8. Altimeter Subscale Setting.....	9
2.9. Altitude Selector 1000 vs Auto.....	9
2.10. Supplementary Procedures.....	9
<b>3. AUTO FLIGHT.....</b>	<b>10</b>
3.1. Calling FMA.....	10
3.2. Don't throw the aircraft at the Autopilot.....	10
3.3. What is A/T HOLD?.....	10
3.4. Heading Select THEN Select Heading.....	10
3.5. VNAV as a Tactical Mode.....	10
3.6. Keep pressing that Altitude Selector ... NOT.....	11
3.7. Altitude Selector and Engine Out Drift Down Descents.....	11
3.8. C'mon Mav, time to do some of that Pilot ........	11
3.9. Before you engage that mode ........	12
3.10. VS : (Not So) Very Special Mode.....	12
3.11. Flight Level Change and SPEEDBRAKE EXTENDED.....	13
<b>4. FLIGHT MANAGEMENT COMPUTER.....</b>	<b>14</b>
4.1. FMC Changes : “Confirm” ... “Execute”.....	14
4.2. Two heads down – FMC.....	14
4.3. Hold Page when Holding.....	14
4.4. Nav aids : To AutoTune or Not AutoTune.....	14
4.5. FMC Default Pages.....	15
4.6. Route Discontinuities are our Friend.....	16
4.7. ALTN Page – DIVERT NOW.....	17
4.8. The FMC is trying to tell you something – why aren't you listening?.....	17
<b>5. NON NORMAL.....</b>	<b>18</b>
5.1. Checklists and Checklist Memory Items you've never seen.....	18
5.2. Fly The Plane.....	18
5.3. Slow down, enjoy the emergency.....	18
5.4. Confirming Memory Items/Checklist actions.....	18
5.5. How to guard a control.....	18
5.6. Mayday vs PAN.....	19
5.7. Oxygen Masks.....	19
5.8. Cabin Altitude Memory Items.....	19
5.9. NNM Checklists Complete ... EICAS Recall vs Review.....	19
5.10. Wake up the PM.....	20

5.11.	Cancelling EICAS – Checklist still to complete .....	20
5.12.	Recovering from TCAS RA (or most Manual Flight NNMs).....	20
5.13.	ECL checklist Title usage .....	20
5.14.	Flaps for Go-Around .....	20
5.15.	Communication after a NNM – who do you call? .....	21
5.16.	Dual Engine Fail/Stall – who flies? .....	21
5.17.	Flaps/Slat problems & Speed Reduction .....	21
5.18.	Flaps/Slat problems & Slower Deployment .....	21
5.19.	Landing using Flaps 20 Yes/No .....	22
5.20.	Setting a NNM Vref – reference the ECL Notes.....	22
5.21.	Slats Drive – Do We Extend the Flaps? .....	22
5.22.	Memory Items Complete .....	22
5.23.	Fuel Jettison, Fuel To Remain – How Much?.....	22
5.24.	Overriding NM Checklist Items.....	23
5.25.	Rapid Descent and Task Protection .....	23
5.26.	Dispatch with a NNM.....	23
5.27.	Fire Engine – Use Your Own Clock.....	24
5.28.	Cabin Altitude Checklist (Silently).....	24
5.29.	Fuel Jettison & Fuel Imbalance.....	25
<b>6.</b>	<b>NON NORMALS ON THE GROUND.....</b>	<b>26</b>
6.1.	Keep the Big Picture .....	26
6.2.	Confirmation is not required .....	26
6.3.	To Stop or Not to Stop ... ..	26
6.4.	Who has the Radio?.....	26
6.5.	Passenger Evacuation & Paper QRH Usage .....	26
6.6.	If you’re going to Stop .....	27
6.7.	Passenger Evacuation & Clearing the Runway .....	27
6.8.	Landing NNMs & Passenger Evacuation.....	27
6.9.	Rejected Take Off – Give the CM1 a Chance .....	28
<b>7.</b>	<b>ENGINE FAILURE AFTER TAKEOFF (EFATO).....</b>	<b>29</b>
7.1.	Engine Failure After Takeoff (EFATO) – Pitch Attitude.....	29
7.2.	Engine Out, High Weight, High Altitude, Turning.....	29
7.3.	TO2 ... Engine Failure ... TOGA ... Vmc A/G? .....	29
7.4.	AICC – Announce, Identify, Confirm, Commence.....	30
7.5.	Fly The Aircraft – What does it mean? .....	32
7.6.	EFATO – Trimming .....	32
7.7.	In Flight Engine Start.....	33
7.8.	Thrust Lever Usage while Engine Out.....	33
7.9.	Engine Out – When do we Accelerate? .....	33
7.10.	Acceleration, Configuration and Memory Items.....	33
7.11.	Engine Failure Handling – a Paradigm Shift.....	34
7.12.	Engine Fire on Takeoff – Early Acceleration & Climb Thrust.....	34
7.13.	Engine Failure Analysis .....	35
7.14.	Engine In flight Re-Starts – Damaged Engines.....	36
7.15.	CLB/CON Thrust during EFATO Acceleration.....	36
7.16.	Engine Out Procedures – AIT.....	36
7.17.	Engine Failure on Takeoff – Overview Diagram .....	37

<b>8. PRE-FLIGHT .....</b>	<b>38</b>
8.1. Pre-Flight Briefing – Management .....	38
8.2. Pre-Flight Briefing – Expediting .....	39
8.3. Aircraft Power Up .....	39
8.4. EICAS Recall during Pre-Flight.....	39
8.5. Pre-flight : Keep the EICAS Clear .....	39
8.6. Starting the APU – Start, Release to ON.....	40
8.7. TFC on the ND during pre-flight.....	40
8.8. Pre-Flight Checklist – Altimeters .....	40
8.9. Seating – Eye Position.....	40
8.10. Defuelling.....	40
8.11. Revising the Standby Fuel Figure (NOT) .....	41
8.12. OPT and Takeoff Performance – Lessons from the Industry.....	41
8.13. OPT Usage – A Practical Application.....	42
8.14. OPT Independent Cross Check – The Next Level.....	43
8.15. ACARS OPT Check – Get what you Need, not what you <b>Wanted</b> .....	43
8.16. FMC Reserve Figure .....	44
8.17. ILS Tuning for Departure.....	44
8.18. Application of CDL Performance Limits.....	44
8.19. Re-Clearance Flight Plans & Final ZFW.....	45
8.20. Noise Abatement - FMC TAKEOFF REF P2/2.....	46
8.21. FMC vs CFP Lat/Lon Waypoints and Positions .....	47
8.22. FMC Track/Distance Checking – Oceanic, Lat-Lon, Off Airway Waypoints.....	47
8.23. FMC Initialisation with ACARS Uplink.....	48
8.24. Use of OFP RAMP and LNDG fuel correction figures.....	49
8.25. Uplinked Winds.....	49
8.26. Final ZFW – What do we do with that? .....	50
8.27. Aircraft DOW & DOI.....	51
8.28. Load Sheet Arrives – OFP Dispatch Message page.....	51
8.29. Cleared to disconnect external power Captain? .....	51
8.30. Pre-Start Hydraulic Pressurisation.....	52
8.31. Dispatch with the DDG – what does “None” <i>really</i> mean?.....	52
<b>9. PUSHBACK, ENGINE START .....</b>	<b>53</b>
9.1. “Can I close the Door Captain?” .....	53
9.2. Pushback Sequence .....	53
9.3. “Cleared to Pressurise?” .....	53
9.4. Start during push back.....	53
9.5. Engine Number One or Left Engine.....	53
9.6. Fuel Control Switch to RUN During Start.....	53
9.7. Starting engines quietly .....	53
9.8. Start Abnormalities and the Outside World.....	53
9.9. Clear to disconnect after Recall.....	54
9.10. Engine Anti-Ice ON after start .....	54
9.11. Guarding Fuel Control Switches .....	54
9.12. Anti-ice and the Before Taxi Checklist.....	54
<b>10. TAXI .....</b>	<b>55</b>
10.1. Takeoff Review – Read the Glass! .....	55
10.2. Weather Radar <b>ON</b> during Taxi.....	55



10.3.	When to run the Before Takeoff Checklist .....	55
10.4.	Thrust Usage on the Ground .....	55
10.5.	Carbon Brakes – Operating Differences .....	55
10.6.	Returning to Stand.....	56
10.7.	Taxi Technique – General Tips.....	56
<b>11.</b>	<b>TAKEOFF .....</b>	<b>57</b>
11.1.	HDG/TRK Select (and HOLD) for takeoff.....	57
11.2.	FMC Climb Direct Feature on the ground .....	57
11.3.	Main gear steering and Thrust Application .....	57
11.4.	Takeoff – wait for 55%.....	57
11.5.	“Takeoff” ... Then TOGA Switch.....	57
11.6.	Eighty knots, Check, Hold, Check.....	58
11.7.	Increasing VR for Strong Crosswind Conditions / Windshear .....	58
11.8.	Flap Retraction & Extension .....	59
11.9.	Takeoff Rotation Rate.....	59
11.10.	VNAV Path after Take Off? .....	60
<b>12.</b>	<b>CLIMB, CRUISE, DESCENT .....</b>	<b>61</b>
12.1.	Filling in a Flight Plan .....	61
12.2.	EDTO Critical Fuel Check.....	62
12.3.	EDTO Critical Fuel – Do We Need It? .....	63
12.4.	Use of VS to change Level at Higher Altitudes .....	63
12.5.	Block Clearances .....	63
12.6.	Updating FMC Winds.....	63
12.7.	EDTO Plotting Chart.....	64
12.8.	Route Offset via Track/Heading Select – Not via LNAV.....	64
12.9.	Step Climbs – OFP vs FMC (Optimum vs Recommended vs STEP).....	65
12.10.	Crew Handover Briefing.....	66
12.11.	Totalizer vs Calculated Fuel .....	66
12.12.	HF Radio Usage .....	67
12.13.	VHF Radio/RTP Usage .....	67
12.14.	Big Font, Little Font – the VOR/DME Ident.....	68
12.15.	Setting up for Approach – PF or PM? .....	68
12.16.	Hand on the Speedbrake Lever .....	68
12.17.	Stowing the Speedbrake near VMO/MMO .....	68
12.18.	Monitor Descent Profile .....	68
12.19.	No Published Transition Level .....	69
12.20.	FLCH Descent at 240 Knots.....	69
12.21.	Setting Vref Early .....	69
12.22.	Enroute CDL Performance Penalties .....	69
12.23.	When do you do the Recall and Notes? .....	70
<b>13.</b>	<b>APPROACH, MISSED APPROACH AND LANDING.....</b>	<b>71</b>
13.1.	VNAV Approach Validation.....	71
13.2.	VNAV Approach – No Path Indicator .....	71
13.3.	Alternate MCP Altitude Setting Technique .....	72
13.4.	Setting DH/MDA for Cat IIIB No DH Approaches.....	72
13.5.	VNAV Approach – Early Descent .....	73
13.6.	VNAV Approach – Speed Jumps Up.....	73
13.7.	MDA or MDA+50?.....	74

13.8.	FLCH during NPA's .....	74
13.9.	Modifying an Existing Hold .....	74
13.10.	Extending the Centerline .....	75
13.11.	VNAV ALT on Approach .....	75
13.12.	“Are you ready for the approach?” .....	75
13.13.	Parallel Runway Awareness .....	76
13.14.	LNAV into Localiser Capture .....	76
13.15.	Localiser Approaches – FMC Selection .....	76
13.16.	Arming Approach Mode .....	76
13.17.	Glideslope Intercept From Above.....	77
13.18.	Circling Minima .....	77
13.19.	Circling approach positioning by triangles .....	77
13.20.	ILS Approach to Circle .....	78
13.21.	Autopilot and MDA .....	78
13.22.	Flt Director OFF at Minima? .....	78
13.23.	Unnecessary Actions during Circling Approaches .....	78
13.24.	“Localizer” vs “Localizer Capture” (... and Glideslope ...)	78
13.25.	Circling Approach : Descent from MDA using AP .....	79
13.26.	Manoeuvring below Minima – Visually .....	79
13.27.	Boeing Thrust Reference Setting Anomaly .....	80
13.28.	CDU VNAV DESC Waypoint/Alt – FPA/Bearing/Vs information .....	81
13.29.	LVOPS – the Last 50 ft.....	81
13.30.	Visual Approaches .....	82
13.31.	Late Runway Change .....	83
13.32.	ANP, RNP, Position and Position Accuracy .....	84
13.33.	Navigational Performance Scales (NPS) .....	85
13.34.	Missed Approach Acceleration .....	85
13.35.	Rejected Landing Procedure.....	86
13.36.	Missed Approach from Above MAA .....	86
13.37.	Clean up, before trying again .....	87
13.38.	Reverse thrust before landing .....	87
13.39.	Reverse thrust after landing .....	87
<b>14.</b>	<b>AFTER LANDING.....</b>	<b>88</b>
14.1.	Autoland – Disconnect AP before A/Brake.....	88
14.2.	CM1 Speedbrake Lever Initiates After Landing Flow .....	88
14.3.	Towed Onto Stand .....	88
14.4.	Parking Brake & The Shutdown Checklist.....	88
14.5.	OFP Completion Post Flight .....	88
<b>15.</b>	<b>DIVERSIONS.....</b>	<b>89</b>
15.1.	General .....	89
15.2.	Extra Documentation.....	89
15.3.	Parking – Nose In? .....	89
15.4.	ADIRU & SATCOM .....	89
<b>16.</b>	<b>DOCUMENT CHANGE HISTORY.....</b>	<b>90</b>

## 1. Document Summary

### 1.1. Why a Practices and Techniques document?

During training instructors and trainees are consistently exposed to normal and non-normal situations that are not experienced during typical line operations. Instructors develop and observe operating practices and techniques that can benefit all crew if communicated in an approved manner to increase the knowledge and understanding of both **the** normal and non-normal operation of the aircraft.

Included in this body of knowledge is the exposure to repeated and repeatable mistakes and practices that lead to undesirable outcomes in both the training and non-training environment. These common errors can also be communicated to crew to the benefit of general knowledge and improved training outcomes. This document serves to share the benefits of the training experience gained by V Australia instructors with line crew.

### 1.2. Is this a procedural document – do I have to follow it?

This document is not to be used as a procedural reference text – for those answers, begin with the Boeing FCOM, FCTM and QRH, augmented by the V Australia SOP Amplification documentation.

This document is background reading and could be considered an historical reference text. If you know your SOPs, and are familiar with glass cockpit jet aircraft – this document for the most part will merely serve to remind you of them.

Many of the issues discussed here are not (yet) documented by V Australia. That does not make them any less valid – nor does it mean they should be followed religiously in anticipation that they will become SOPs. What's written here should make you stop; think; and reach your own conclusions.

The real intent of this document is to give students the opportunity to read about the mistakes observed to have been made by others, so they can go on to make new and completely original mistakes.

### 1.3. Checklist and Checklist Memory Items

In the last few years, Boeing removed the use of the word “Recalls” when referring to the memory items on NNM checklists - possibly because of confusion with the Recall/Cancel switch. Instead these items are referred to as “**Checklist Memory Items**”. Hence when a NNM event occurs that requires the actioning of a checklist with memory items, crew no longer call for “**Fire Engine Right Recalls**” but “**Fire Engine Right Memory Items**”. As much as a tongue twister as this is on the flight deck when you're under pressure, it's even more difficult to refer to clearly in print. As such in this document:

- When you read “**Checklist/Memory Items**” this means Checklists OR Checklist Memory Items (in other words, Checklists or Recalls).
- When you read “**Checklist Memory Items**” this means just that – the memory items of a NNM checklist (i.e. “Recalls”).

## 2. General Observations

### 2.1. Recall during Flows

There are several EICAS **Recalls** during flows, such as Before Start, After Start and prior to the Descent Checklist. These are actioned by the PM (or CM2) but require the involvement of the PF (or CM1). The correct procedures for all EICAS/ECL handling are documented in the EICAS/ECL SOP Amplification.

A correctly executed Recall begins with a clear EICAS display. PM/CM2 presses the Recall/Cancel switch, **calling out** the white **“Recall”** message **from the** EICAS. PF/CM1 verifies the **“Recall”** as displayed on EICAS – which confirms that the first page of EICAS messages is being displayed. PM/CM2 reads the displayed messages, while PF/CM1 verifies the messages and if willing to accept the next stage of flight, calls **“Cancel EICAS”**. PM/CM2 cancels the EICAS (potentially, one page at a time) and continues the flow.

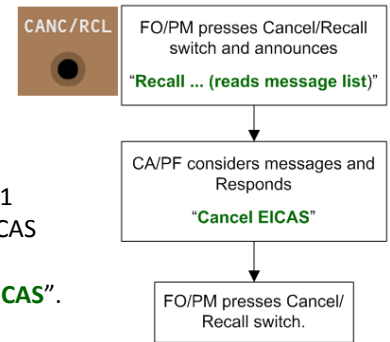

### 2.2. ATC make mistakes

It is an oversimplification to say that Australian domestic pilots tend to manifest a belief in the infallibility of ATC. That said – simulator experience indicates that this seems to be the case. One lesson that comes from overseas experience is that ATC **can** direct you into terrain; ATC **can** direct you into other aircraft; ATC **can** direct you into severe weather.

It is also even more accurate to say that in the **simulator** – ATC **will** direct you into hills, other aircraft and weather.

**It is the pilot who is responsible for terrain clearance at all times.** It is also the pilot who wears the consequences of any lack of vigilance in this regard. This includes during radar vectoring. Areas of the world with a history of terrain clearance issues provide a MVA or MRC chart to enable pilots to cross check position with a minimum radar vectoring altitude. However the non-existence of a MVA/MRC chart does not infer that mistakes have not been made in radar vectoring.

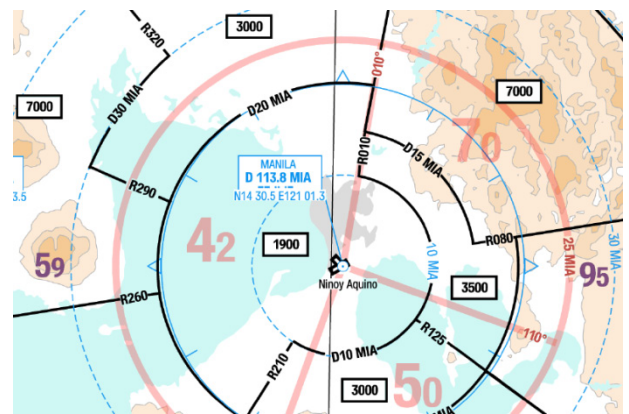

At any time during the flight a crew should be able to quickly determine a safe minimum altitude for the aircraft – particularly during climb and descent.

There is a call in the V Australia SOPs to highlight the fact that the aircraft has been cleared below MSA. The intent of this call is not just to highlight the point at which the aircraft descends below MSA – but to raise the situational awareness of the crew that it has been cleared **to descend below** MSA and is about to do so.

PF : **“Cleared Below MSA”** ... PM : **“Check”**

### 2.3. Checking the next checklist

When a NM checklist is **“\_\_\_ Checklist Complete”** the EFIS **CHKL** button should be pressed and the ECL closed. There is no need to click on the ECL **NORMAL** prompt to display the next checklist, nor should the **CHKL** button be pressed again to check if the next NM checklist is there, or to ensure the next checklist will not be forgotten. This habit also goes against the recommended technique of keeping the lower MFD clear unless it’s being used for a real purpose.

### 2.4. Keep the Lower MFD Clear

The lower MFD with its access to synoptics and ECL NM and NNM checklists is there to be used by the crew. That said, unless the lower MFD is being used for a purpose, it should be kept clear. This includes not displaying the next checklist when the SOP doesn’t call for it, and not displaying the secondary engine page continuously in flight.

### 2.5. PF does the Rudder Trim

The rudder trim control is in the PF’s area of responsibility in flight. There is a technique that has been taught at various times during engine failures after takeoff where the PF is encouraged to call for the PM to trim the rudder, when the workload on the PF is high and the aircraft close to the ground. This technique is discussed elsewhere (**7.6 EFATO – Trimming**) – but in any case, it does not apply at any other time. When an engine and the TAC fail at altitude, trimming the rudder is the responsibility of the PF. PM trimming the rudder is the exception, not the rule.

## 2.6. Glass Cockpit Scan

Apart from the PFD and ND, the EICAS and to a lesser extent the CDU (scratchpad) should also be in a Pilot’s scan. When an instructor sees trainees who are technically under low workload levels not noticing an EICAS advisory message for several minutes (bearing in mind it’s the instructor who generated the message), it’s usually a sign of a poor scan technique.

The scan of the ND should include reference to the current leg and active waypoint. It should be considered unusual to have an ND display that does not show the active waypoint. Keep your ND Map Scale at a value that promotes situational awareness – not detracts from it. Getting airborne in the sim with a 10 mile scale and keeping it there for the next ten minutes is just asking your instructor to place a CB 20 miles ahead ...

## 2.7. Two heads down – in general

This is probably one of the most common errors of a highly automated flight deck. The PF should be acutely aware of any tendency to watch what the PM is doing instead of flying the aircraft, and especially aware of assisting in the PM duties, instead of flying the aircraft.

A degree of two heads down will be tolerated, even encouraged during early simulator FBS transition training in order to maximise crew exposure to the lessons being taught, but as the crew moves into FFS, the simulator should be treated as an aircraft and two heads down avoided as the flight safety risk that it is.

## 2.8. Altimeter Subscale Setting

Altimeter subscale setting and the subsequent cross check is crucial beyond the importance accorded to it in SOP’s and Flight Operations Manuals. Incorrect subscale settings have caused accidents in the past. RNAV/GNSS approaches in particular are very susceptible to incorrect altimeter settings. Transition and the subsequent crosschecks, along with QNH changes and a subsequent altimeter cross check should be given a high priority, even in a busy flight deck – it’s part of **Fly The Plane**.

That said, remember that in the 777 during normal (no system degradation) operations, the cross check is the subscale only (**8.8 Pre-Flight Checklist – Altimeters**) and not an altimeter readout check.

## 2.9. Altitude Selector 1000 vs Auto

By habit the altitude selector should be left in the 1000 position. This is by far the most common usage when selecting altitudes (by 1000’s). **If a non x1000 intermediate altitude or MDA needs to be set, then selector should be moved to Auto, the altitude set,** then the selector placed back in the 1000 position.

## 2.10. Supplementary Procedures

The Boeing FCOM incorporates a number of Supplementary Procedures which cover the range of aircraft supplementary operations. Some of the supplementaries include procedures that are run by the crew on a step by step basis, some provide background information to a process that crew perform regularly by memory.

In many cases Supplementary Procedures should be reviewed by the crew (as a crew) prior to the actual need for the procedure. With procedures such as those associated with Engine Starting a good technique is to review the relevant procedure as part of the “Operational” component of the C-Two-Plus briefing. A general knowledge of the procedures and information topics that exist in the FCOM supplementary is an important component of 777 flight operations.

You can’t call for the correct SP if you don’t know what it does, or that it exists.

Supplementary Procedures		Chapter SP
Table of Contents		Section 0
Cold Weather Operations	Airplane General, Emer. Equip., Doors, Windows	SP.1
Exterior Hot Weather Operat	Doors	SP.1.1
Engine Start	Entry/Service Door Closing	SP.1.1
Engine A	Entry/Service Door Opening	SP.1.1
Automatic	Emergency Equipment	SP.1.2
AFDS	Emergency Oxygen Use	SP.1.2
Structural Consi	Flight Deck Door Access System Test	SP.1.2
Climb, Cruise, a		
Manual Flight in		
Heading	Communications	SP.5
Heading	Flight Deck Communications System (Datalink)	SP.5.1
Track B	Flight Instruments, Displays	SP.10
Track S	QFE Operation	SP.10.1
Altitude		
Flight Level Change		
Vertical Speed, Climb	Electrical	SP.6
Flight Path Angle, Cl	Electrical Power Down	SP.6.1
Anti-Ice, Rain	Electrical Power Up	SP.6.2
Inst	Anti-Ice Operation	SP.3.1
Windshield Wiper Use	SP.3.1	SP.11.2
		SP.11.3



### 3. Auto Flight

#### 3.1. Calling FMA

All FMA changes (including mode arming) should be called. This begins with the “**Thrust Ref**” call after **THR REF** is engaged during the takeoff roll, through to the last FMA change above 200 ft on approach, normally “**Land Three, Rollout and Flare armed**” after 1500 ft AGL.

#### 3.2. Don't throw the aircraft at the Autopilot

It would be somewhat unusual for a pilot to raise the nose to 20°, roll in 35° of bank, close the **thrust** levers and call across to the other pilot “**You have control.**” Apart from anything else, it's rude. However there seems to be no such inhibition when it comes to throwing the aircraft at the autopilot.

The Boeing FCTM requires that the aircraft be **in trim** (this includes rudder) and **satisfying the commands of the Flight Director** prior to AP engagement. Those of you who have handed the aircraft over to the autopilot when neither of these requirements were being met, only to have the AP then disengage (you know who you are) – are effectively demanding more of the AP than it can cope with.

Typical examples of poor AP engagement behaviours are observed after TCAS RA or Windshear recovery where FMA modes are inappropriate for the flight path required, the FD's are not being followed, but the aircraft is thrown at the auto pilot anyway.

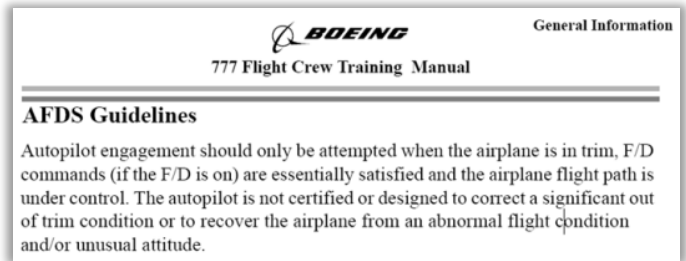

#### 3.3. What is A/T HOLD?

Auto-throttle HOLD mode is the equivalent of the auto-throttle saying to the PF “**You Have Control.**” At this point, the A/T is still armed and can potentially re-engage without an associated Pitch FMA change, but basically the A/T has set a thrust (usually, but not necessarily IDLE) and has then taken its “hands” off the thrust levers. The PF can increase or decrease thrust to modify the rate of descent (such as during FLCH Descents).

This is quite critical on takeoff when the A/T annunciates HOLD just after 80 knots. By this stage, takeoff thrust must have been set in order to satisfy the performance requirements of the takeoff. Crucially, if after this point the CM1 decides an increase in thrust is required, CM1 can advance the thrust levers to increase thrust without fighting the A/T.

#### 3.4. Heading Select THEN Select Heading

When Heading/Track Select is engaged, the AFDS initiates a turn towards the heading/track bug **in the shortest direction of turn**. This means if the crew are executing a near 180° turn and do so by first setting the heading bug, then engaging heading select, the aircraft could well turn in the wrong direction.

**For this reason it is good practice to engage heading select before turning the heading bug.** Note however that crew should not engage heading select without first having an awareness of where the heading bug is and which way the AFDS will turn. Since one of the tasks of the PF (or PM if the AP is not engaged) is keeping the heading bug in synch, it should all go swimmingly well ...

#### 3.5. VNAV as a Tactical Mode

Generally VNAV is not good for those tactical **speed/altitude** changes. The MCP is where you want to be implementing those short term vertical flight pitch changes, unless it's changing cruise level in a low workload environment.

For example, when told to limit your speed on climb until a certain level, there is a small advantage of VNAV – you can set 230/15000 in the VNAV CLB page and the aircraft will accelerate by itself as you climb through FL150 (all else being equal). However this is considered a small benefit as opposed to the heads down requirement of implementing this in the FMC at low level (below 10,000 AGL) and the increased opportunity for error this introduces into the Flight Deck.

Generally speaking – use the MCP for lower level vertical path (speed/altitude) changes. Just don't forget to keep that change in your mind if you have to cancel it later.



### 3.6. Keep pressing that Altitude Selector ... NOT

When an instructor sees a student needlessly pressing the altitude selector after a selected altitude change, it can be an indicator of several things. Primarily automation confusion, but it is also often an indication of the lack of AFDS situational awareness. There are generally four reasons to press the altitude selector after an MCP selected altitude change.

- The aircraft is in VNAV ALT or VNAV PATH and the PF wishes to initiate a climb/descent.
- The aircraft is in VNAV SPD (climb or descent) or VNAV PATH (descent) and the PF wishes to delete the next RTE LEGS page speed/altitude restriction (which is between the aircraft and the MCP selected Altitude Selector).
- The aircraft is NOT in VNAV, but the PF wants to delete the next RTE LEGS page speed/altitude restriction.
- The pilot needs to increase the Cruise Altitude in the FMC Cruise Page, based on the MCP Altitude Selector.

The most common error is level flight in basic (non VNAV) modes, a new altitude is selected and the PF presses the altitude selector to commence the climb/descent. The habit of pressing the altitude selector needlessly can cause difficulties when approaching a VNAV NPA approach as the PF can un-intentionally delete the altitude restriction at the IAF (or elsewhere on the STAR/approach).

### 3.7. Altitude Selector and Engine Out Drift Down Descents

The question often arises whether you should press the altitude selector during the commencement of an Engine Out Drift Down descent. Firstly – go back and read the paragraph **3.6 Keep pressing that Altitude Selector ... NOT**

If the standard procedure has been followed to commence an engine out descent in VNAV, there are now **three** (perhaps **four**) reasons to use the altitude selector.

- The FMA is in VNAV ALT (Either it was VNAV ALT before the engine failure, or the altitude selector was not reset to the preferred engine out level off altitude when the EXEC button was pressed) – Pressing the altitude selector once will commence the Engine Out Drift Down if the MCP Altitude is **first** set correctly.
- The Altitude selector is set to a different altitude (usually a quadrantal level) to the FMC Engine Out Cruise Altitude and PF needs to **update** the FMC Cruise Altitude to **match** the MCP selected altitude – pressing the Altitude Selector will achieve this.
- **Once commenced, the crew decide to expedite descent to the selected engine out cruising altitude. Pressing the Altitude Selector at this point will transition VNAV to either a cruise descent (1250 fpm) or an idle thrust descent.**
- **Potentially, if the aircraft was near top of descent AND there was an altitude restriction on the legs page above the new Engine Out Cruise Altitude, the altitude selector may be required to clear that restriction.**

Note that pressing the altitude selector during an engine out drift down unnecessarily can result in the FMC transitioning from an engine out drift down into a cruise descent of 1250 fpm, or a standard idle thrust descent.

### 3.8. C'mon Mav, time to do some of that Pilot ...

Pilots new to the aircraft tend to be enamoured with the FMC (especially once they begin to understand it), at times to the exclusion of common flying-the-plane sense, particularly in a training environment. For example:

You are level at 9000 ft after departing Sydney (VNAV ALT for those who looking at their FMA). It's 09:56 UTC and ATC want to know if you can reach FL150 by time 1000z. How can you find an answer to this?

- You can look at the legs page. If there's a waypoint near the time 1000z, it may have a crossing altitude that will tell you what altitude the FMC is planning you at for that time. That'll be pretty close.
- You can place FL150 in field 6R on the Fix page. This will give you a distance to run to that point on your present track. You can then convert that distance to an altitude using a magical formula that I haven't thought of yet.
- You can change your cruise altitude to FL150. Then the FMC will give you a time at top of climb on the Progress and VNAV CLB pages.

**Or** you could verbalise something like "Ok, six thousand feet in four minutes means 1500 fpm to FL150 – not a problem – tell them Yes." Turn and Burn.

3.9. Before you engage that mode ...

Crew should not select an AFDS mode without an awareness of what flight path changes will result from the associated mode engagement. As obvious as this may sound, crew new to the Boeing AFDS have a tendency to “throw” the aircraft at the AFDS. Considerations for the various mode engagements are details in this table.

In many cases, the selection of AFDS modes is the result of a process following an ATC instruction and the considerations here are superfluous. In the case of VNAV, often insufficient automation knowledge exists to anticipate the result of mode engagement.

Remember when you’re about to engage heading select, the information you need to know is on the PFD/ND heading bug indication. When you’re about to engaged FLCH, the information you need to know is the selected altitude on your PFD.

AFDS Mode	Considerations
HDG SEL TRK SEL	<ul style="list-style-type: none"> <li>Where is the Heading/Track Bug?</li> <li>Which way will the aircraft turn?</li> <li>Are you in Heading or Track reference?</li> </ul>
FLCH	<ul style="list-style-type: none"> <li>Where is the Altitude Selector set?</li> <li>Are we going to Climb or Descend?</li> </ul>
LNAV	<ul style="list-style-type: none"> <li>Where is the active waypoint?</li> <li>Where is the active flight leg?</li> <li>Is LNAV going to ARM or ENGAGE?</li> </ul>
VNAV	<ul style="list-style-type: none"> <li>Is the FMC in CLB, CRZ or DESC mode?</li> <li>Where is the VNAV Profile at this point?</li> <li>What speed will VNAV command?</li> <li>So, what will the aircraft do?</li> </ul>
APP LOC/GS	<ul style="list-style-type: none"> <li>Is the ILS Tuned / Identified?</li> <li>What are Localiser/Glideslope indications?</li> <li>Are you expecting Arming or Engagement?</li> </ul>

When you’re about to engage LNAV, the information you need is on the ND – the active waypoint, the active leg, the aircraft position.

When you’re about to engage VNAV, the complete picture is partly PFD – current altitude, selected altitude – but mostly the VNAV CDU page – whichever one (CLB/CRZ/DESC) pops up when you press the CDU VNAV switch.

3.10. VS : (Not So) Very Special Mode

There is a perception that VS (and by association, FPA) is somehow an AFDS mode with inherent flight safety implications and should only be used as a last resort. Generally speaking this attitude stems from a poor understanding of the AFDS VS/FPA mode. While FLCH is usually superior in most situations to VS, there are a number of situations where VS is highly appropriate.

It is true that VS has some issues related to airspeed. These issues are inherent in the design of the mode – unlike FLCH and VNAV SPD, the primary controlling parameter is not IAS. As such, IAS is sacrificed where necessary to maintain the primary controlling influence of Vertical Speed. Therefore VS/FPA can be inappropriate at high altitude (and/or high weight) when thrust is insufficient and airspeed may reduce towards minimum manoeuvring margin. Very high VS selections in either climb or descent can result in inappropriate speed excursions.

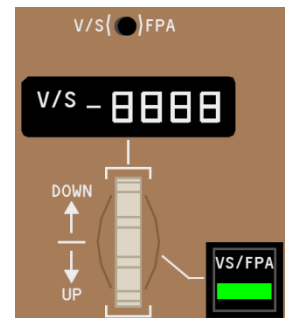

One specific issue is the use of VS or FPA at high altitude. Engaging VS/FPA from VNAV opens the speed window to the current IAS indication. VS/FPA level changes with IAS as the parameter commanding elevator at high altitude is inherently risky – the MCP airspeed selector should be changed to MACH.

VS/FPA however is the mode of choice for:

- Reducing rate of climb or descent when approaching an altitude/level and other aircraft are in the vicinity.
- Non Precision Approaches when VNAV is not available.
- Continuous Descent Arrivals.

### 3.11. Flight Level Change and SPEEDBRAKE EXTENDED

Often the PF will select FLCH for a smaller altitude change (generally less than 3000 ft) and subsequently commence Speedbrake extension to increase the rate of Descent. Occasionally this will result in a **SPEEDBRAKE EXTENDED** Caution Message and Beeper. At this point the PF realises that the thrust levers are at an intermediate thrust setting, instead of **IDLE** – hence the EICAS Caution.

It's worth noting that a FLCH descent is not necessarily an idle thrust mode. FLCH determines a thrust setting based on the level change requirement. Smaller level changes (generally requiring less than three minutes to complete) will result in an intermediate thrust setting. This can be determined from the THR annunciation on the AFDS, rather than either IDLE or HOLD.

The solution to FLCH/Descent/**SPEEDBRAKE EXTENDED** is generally to follow through on the thrust levers during FMA mode changes and close the thrust levers manually prior to extending the Speed brake lever.

The thrust setting calculation performed by FLCH works this way for climbs as well. FLCH may well set less than the current thrust limit in order to achieve a level change in (approximately) two minutes.

## 4. Flight Management Computer

### 4.1. FMC Changes : “Confirm” ... “Execute”

Strictly speaking, all FMC changes that result in the activation of an Execute light should move the PM to call “**Confirm?**” to the PF, and upon verification, the PF should respond “**Execute**”. Trainees tend to be fairly good in this regard when all is quiet at altitude and operations are normal, but this highly recommended safety/situational awareness technique tends to be abandoned with the pressure is on during NNM events. **This is exactly the time when the confirmation of FMC changes should involve the other pilot.**

Another aspect of the **Confirm ... Execute** technique is that it tends to separate the roles of the two crew members on the flight deck – one pilot makes the change, the other approves it, and we avoid both pilots being heads down at the same time.

A useful tip for the PF when confirming Direct To’s that don’t **easily** show on the ND (such as when a significant distance away) is for the PF to briefly switch to PLAN mode on the ND. Usually this will show the Direct To waypoint centrally on the screen with the dashed white modification line leading straight into it for a quick, accurate confirmation of the pending modification. **Ensure the correct ident has been used however and gross error check the distances involved.**

### 4.2. Two heads down – FMC

Contrary to popular belief (and simulator experience) – **it only takes one pilot to make a change to the FMC**. In fact changes to the FMC seem to occur faster, with less error and a more positive post-change / pre-execute cross check, when only **one** pilot is involved in making the entries.

So as the PF, resist the temptation (especially during training, altitude/level changes, approach, Non Normals and other high workload activities) to get involved in the PM’s manipulation of the FMC. Be patient – PM will find the right page eventually, and probably learn more from the self discovery experience as well. When prompted “**Confirm?**” do a positive cross check that the changes are as requested before confirming “**Execute.**” As the PF, isolating yourself from the process of modifications to the FMC helps enforce your role as an independent verifier of the changes made.

### 4.3. Hold Page when Holding

Ideally the FMC Hold page should be displayed on a CDU (typically the PF side) when entering a holding pattern, and while holding. If the CDU is required for another purpose then it should be used at the requirements of the crew, then returned to the Hold page when no longer required. The crew who keeps the Hold Page up on a CDU tends to be the one that remembers to activate **Exit Hold** before it’s too late.

### 4.4. Nav aids : To AutoTune or Not AutoTune ...

Choosing to manually tune the VOR’s for departure and arrival is usually a personal choice. However the following factors should be taken into account when deciding to manually tune the VOR’s (and thereby disable AutoTune for that receiver):

- Generally AutoTune will select the correct aids based on the SID/STAR/Approach/Missed Approach programmed in the FMC. However if you fly a procedure that is not stored in the FMC database, AutoTune may not be helpful.
- Usually the Left VOR will tend to tune forwards, the Right VOR will tend to keep over flown VOR’s active a while longer (very subjective).
- Sometimes a better alternative to manual tuning is to back up AutoTune with appropriate pre-selects, ready for selection in the event that AutoTune does not function as desired.
- Some crew advise using VOR frequencies in the pre-selects rather than navaid identifiers. This means that in the event of a double FMC failure, the pre-select frequencies will work (Navaid Idents would not be recognised by the CDU). This is fine as far as it goes, however the more likely event is an AutoTune problem, and the Navaid Idents tend to be easier to recognise when trying to get back an Aid after an AutoTune problem than the frequencies.
- AutoTune is not perfect – often it tends to tune forwards when the PF would prefer to retain the over flown aid. The times and places this occurs become known to crew who remember to include raw data in their scan ...
- Manual Tuning is perfectly acceptable and within the responsibility of the PF (PM should be made aware). Typically manual tuning is employed when a particular procedure has a known associated history of undesirable AutoTuning.
- Try to remember to restore the VOR receiver to AutoTune once Manual Tuning is no longer required.

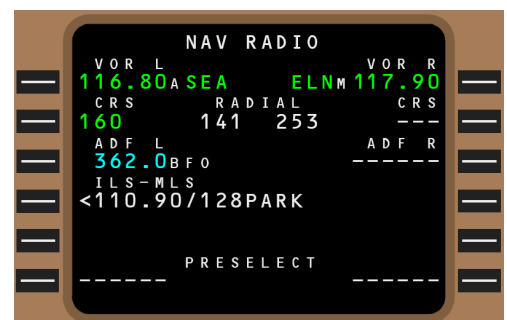

#### 4.5. FMC Default Pages

There are some recommended pages for the FMC CDU at various stages of flight. **These are NOT mandatory.** If a pilot wishes to use another page with better information relevant to the situation at hand, this is good airmanship and is to be encouraged. However experience has found that certain pages offer the best access to information and automation management at certain phases of flight.

Note that poor CDU page selections for significant amounts of time are indicative of poor scan rate and lowered situational awareness on the part of either or both pilots.

Flight Stage	Recommendation	Reasoning
<b>Pre-Flight</b> Performance Entry	CDU-L : PERF INIT	After CDU Pre-Flight, but prior to final load notification, if the CM1 keeps the Left CDU on PERF INIT page, this assists in remembering to enter the performance data.
<b>Taxi</b> Prior to the Takeoff Review	CDU-R : RTE Pg 2	Displayed for the SID identifier (or lack thereof) in the Takeoff Review.
	CDU-L : TAKEOFF REF	Displayed for the Flap, Runway and $V_2$ in the Takeoff Review.
<b>Take off</b>	PF CDU : TAKEOFF REF; or VNAV CLB	The Boeing FCTM recommends the TAKEOFF REF page for the take off roll in the event that the PF needs quick reference to the takeoff speeds. Experience has also proven the value of the VNAV CLB page, giving the target speed airborne ( $V_2+25$ ) as well as the first waypoint with an altitude/speed restriction in the departure. Note that once airborne, a single press of the INIT REF key will display the THR LIM page for quick access to alter the climb thrust limit selection.
	PM CDU : LEGS	The LEGS page gives the PM quick access to departure routing changes, as well as both pilots an overview of the speed and altitude constraints on the departure.
<b>Cruise</b>	PF : VNAV CRZ	Generally PF will keep the VNAV CRZ page displayed when no other page is required. This gives access to cruise altitude related information such as Maximum/Optimum/Recommended and predicted Step Altitudes.
	PM : LEGS	By default, the LEGS page is usually displayed by the PM. Some crew prefer the PROGRESS page or LEGS RTE DATA for time and fuel estimates.
<b>Descent</b>	PF : VNAV DESC	The VNAV DESC page gives the PF quick reference to descent speed, speed transition and the next waypoint speed/altitude limits. Reference is often made to the PROGRESS pages for distance to run to destination for height/distance cross checks.
	PM : LEGS	The venerable LEGS page gives the PM (and PF) access to speed/altitude restrictions as well as giving the PM quick access for arrival routing changes.
<b>Holding</b>	PF : RTE HOLD	When slowing to holding entry speed and while established in the hold, it is recommended for one CDU to display the RTE HOLD page.
<b>Approach</b>	PF : Various	VNAV DESCENT gives the Waypoint Speed/Altitude restrictions, as well as Waypoint VB/VS/FPA information. PROGRESS Pg 2 gives VNAV profile deviation, as well as Tail/Cross Wind components and LNAV deviation.
	PM : LEGS	LEGS page for speed and altitude restrictions, particularly during NPAs is recommended.

#### 4.6. Route Discontinuities are our Friend

There is a misconception that route discontinuities are a bad thing that must be removed from the flight plan during pre-flight or during approach preparation.

The Boeing FCOM does not help in gaining an appreciation of the usefulness of route discontinuities, advising that all discontinuities should be cleared. This is a fairly simplistic view of what is actually a very useful tool in the real world airline environment.

Route discontinuities come about because one part of the route does not meet up with a subsequent part of the route. Often this occurs for a very good reason.

Most common on departure is the discontinuity after a SID that does not meet up with the CFP route – the Sydney RW16R KAMPI departure for example. Before removing the discontinuity – crew should ask themselves “**Why is it there?**” In the case of the KAMPI departure, the question is more correctly “**What do I want the aircraft to do after KAMPI?**” The SID is designed such that the aircraft should be given a vector, or cleared direct to an enroute waypoint prior to KAMPI. But in the event this does not happen – what would you want the aircraft to do? What would ATC expect you to do? If you remove the discontinuity, the aircraft will turn and track towards the next waypoint (for example, WOL on the way to Melbourne), which may not be the best action.

What happens if the aircraft flies into a discontinuity? The CDU scratchpad displays **ROUTE DISCONTINUITY** and an associated EICAS **FMC MESSAGE** will display. LNAV will remain engaged, as will the autopilot. The AP/FD will command straight ahead. Essentially the aircraft keeps flying, but **communicates** you have a problem to solve.

Another common cause of route discontinuities is data problems with uploaded flight plans. An historical example would be flights planned enroute over Ayers Rock. The identifier for the NDB and the VOR at Ayers Rock was AY. Since the CFP uplink could not determine which waypoint to use, the FMC would instead insert a discontinuity. Crew would close the discontinuity without determining the reason for it (or cross checking the CFP correctly) and the FMC would contain the uplinked flight plan without Ayers Rock. The aircraft would fly across the area without Ayers Rock being reported through FANS and ATC would file a report.

Another common use of discontinuities is during descent phase. For airfields without published STARS, the CFP and airways clearance will often plan for the aircraft to track to the primary aid at the airfield – usually the VOR. Experience tells you to expect to be vectored from about 20 miles towards a downwind position. A PBD waypoint (VOR/-20), followed by a route discontinuity, then the instrument approach can leave you with a legs page that will comply with your clearance (even after the discontinuity, it will continue to track towards the VOR) but provide the FMC with the right track miles to provide a reasonable VNAV descent profile. If you get to 20 miles without a vector – AP/FD commands straight ahead and you are informed of the problem via scratchpad/EICAS.

The long and the short of route discontinuities is – they are there to be used and when used, should be briefed as to the intent of the discontinuity and the action that will be taken as it is approached.



**Flight Management, Navigation Chapter 11**  
**Flight Management System Operation Section 31**

**Preflight**

The departure/arrival (DEP/ARR) page can be used to select a SID. Selection of the SID may cause a route discontinuity. Resolution of the discontinuity and execution of the modification should be accomplished on the ROUTE or LEGS page.



4.7. **ALTN Page – DIVERT NOW**

Unless you are being radar vectored back to your departure airport, the ALTN page is the quickest and most complete method for setting up a diversion in the FMC. The **DIVERT NOW** prompt clears out all the legs page entries except that required to return and sets the new destination airport in the Route page, which gives access to the STARS and approaches for the airport.

A common error associated with this FMC feature is the deletion of the active waypoint the PF is using in LNAV – or the holding pattern the aircraft is currently following.

Most commonly **DIVERT NOW** is used to:

- Route direct to the airport identifier (eg: YSSY); or
- Route first to a waypoint that is already on the LEGS page (not necessarily the active waypoint) then the diversion airport identifier.



Best practice is to use the **DIVERT NOW** prompt on the individual airfield page of the ALTN page, to verify the choice of diversion waypoint prior to selecting the feature. Ensure either DIRECT TO or OVERHEAD XXX has been selected (<SEL>) as desired by the PF.

Finally, when the Execute light is lit – a **check of the LEGS page on the CDU** (either PF or PM side) gives a last chance opportunity to save the Hold or Active Waypoint that wasn't supposed to be deleted.

This last LEGS page check is what the FMC does when the Final Course INTC feature is selected from the DEP ARR page. This feature also deletes all LEGS page waypoint, and establishes an inbound final approach course to a database selected final approach course fix. Prior to execution, the pilot is **automatically** shown the LEGS page so the destruction of the flight plan can be confirmed prior to execution. Unfortunately Honeywell did not implement this feature in the **DIVERT NOW** feature logic – so you should do it.

4.8. **The FMC is trying to tell you something – why aren't you listening?**

The CDU scratch pad is the FMC's only way of trying to tell you something. Messages like "VNAV/PERF UNAVAIL" or "INERTIAL/ORIGIN DISAGREE" or "ROUTE DISCONTINUITY" are the FMC's way of communicating a problem to the crew – a problem that is valid, even if the crew don't understand the message. **It's not uncommon to see crew clear those messages with minimal acknowledgement, a habit that unfortunately commences during simulator training.**

CDU Scratchpad messages need to be dealt with like any other annunciation in the flight deck. Noticed, Called, Analysed, Acted Upon. **Some of the more common (ly ignored) FMC messages are listed here.**

FMC/CDU Message	Meaning
<b>INSUFFICIENT FUEL</b>	Because of a change in flight conditions or the route, the computed route fuel burn exceeds the total fuel on board, less reserves. Is there a valid reason for this?
<b>UNABLE HOLD AIRSPACE</b>	The radius of the holding pattern, calculated by the FMC, exceeds the FMC maximum protected airspace limits.
<b>UNABLE CRZ ALT</b>	Performance predicts a zero cruise time at the entered cruise altitude. Typically if the FMC was in VNAV CLIMB mode (note FMC not necessarily the Aircraft) but has now calculated the programmed Cruise Altitude is not feasible. The FMC has in effect just transitioned to VNAV DESC mode and should begin to calculate a descent path.
<b>RW/ILS CRS ERROR RW/ILS FREQ ERROR</b>	Either the airplane is within ILS automatic tuning range and the tuned ILS frequency/course does not match the frequency/course for the active arrival runway, or the FMS is not receiving valid course data from the same ILS that the FMS is using for frequency data, or valid frequency data from either ILS.

**A complete list of FMC/CDE messages and their meanings can be found in the Boeing/Honeywell 777 FMS Guide.**

## 5. Non Normal

### 5.1. Checklists and Checklist Memory Items you've never seen

The Boeing Flight Training transition course is reasonably complete. It's certainly considered complete by CASA, who certify crew as type rated as the result of successfully completing the course. But it certainly does not cover all the available non normals, nor practice and evaluate all of the Checklists and NNM manoeuvres present in the QRH and FCTM.

So if you front up to a refresher course having been signed out on your Type Rating, OPC/IR check – and encounter an event in which you are required to action a checklist with memory items, or fly a manoeuvre you don't know, because you haven't seen it in the simulator – whose fault is that?

As a general principle, students on transition course should also consider all un-annunciated checklist titles and condition statements as memory items along with the memory items in all checklists. Action items associated with manoeuvres such as the Terrain Escape Manoeuvre and Windshear are also to be memorised.

### 5.2. Fly The Plane

In a training environment, these words, this thought process, the actions associated – all should be foremost in a Trainee's mind.

- Instructor asks you “**What would your initial actions be in the event of an engine failure at altitude?**” The answer is: “**Fly The Plane.**”
- Instructor asks you “**What would you do in the event of an FMA VNAV ALT annunciation when you engaged VNAV prior to commencing an NPA?**” The answer is: “**Fly The Plane**”
- Instructor asks you “**Are you buying the beer in the pub tonight?**” The answer is “**Yes**” and “**Fly The Plane**”

### 5.3. Slow down, enjoy the emergency

Yes, it's an airborne emergency. Yes, quick action may be required (rarely). Yes, you knew it was coming (in the simulator). Yes, you know how to deal with it. All of these are **not** reasons to justify quick and **possibly** ill-considered actions during a Non Normal. You are usually advised to treat the simulator like the aircraft. In that case – slow down! Statistically, this is the only engine failure you ever going to see – slow down, enjoy it, get it right.

Indications of the need for a crew to slow down include hunting for the Engine Fail checklist in the ECL before the  **ENGINE FAIL** message has **even** made it to the EICAS. The response to an engine failure (or any malfunction) should include a **failure analysis**, prior to selecting the checklist to be actioned.

Another indication of rushing is launching into the Cabin Altitude Memory Items prior to the (relatively) slowly climbing cabin reaching 10,000 ft. Ideally, it would be nice to confirm an inability to control the cabin, prior to descending to 10,000 ft and committing the aircraft to a new destination for a malfunctioning outflow valve.

The right action, implemented after some thought and analysis will almost always provide a better solution **– or at least the same one –** than an impulse response, irrespective of whether it is right or wrong. In this regard – two heads are usually better than one.

Checklist memory items and checklist actions should also be competed in a calm, unhurried, crew co-ordinated manner. While items which are irreversible, or have a significant impact on flight safety are generally confirmed by both pilots – there are still many items in the various checklists and memory items which are not – but can make life very difficult when you action the wrong switch, or the right switch in the wrong manner.

### 5.4. Confirming Memory Items/Checklist actions

Often the PM falls into the habit of confirming all checklist actions with the PF during NNMs – especially when new to the aircraft. There is actually a very limited set of controls that need the confirmation of the other crew member prior to being actioned during a Memory Item/Checklist. There is no need for the PM to confirm **all** the items in a NNM checklist with the PF.

### 5.5. How to guard a control

Note that the guarding of controls is optional in V Australia.

When guarding a control (such as the Fuel Control Switch), **the PF should not grip the control**, as if about to action it; rather PF should prevent the control from being actioned – even by the PF. An example of this methodology in action is resting a clenched fist on the Engine Fire Switch (so that can't be pulled) as well as up against the fuel control switch, so that it cannot be selected to Cutoff.

## 5.6. Mayday vs PAN

Boeing documentation does not provide clear guidance on what conditions should result in a Mayday call to ATC, vs what call should result in a PAN PAN PAN. Anytime the checklist calls for **Land ASAP** crews should consider one these calls. Other considerations are as follows.

- Any time critical failure such as an un-extinguishable engine fire or un-controlled (or un-determined source) smoke/fire in the cabin should be a Mayday call.
- Severe engine failures, engine fires, smoke/fire in the cabin (whether under control and/or source) – should be a Mayday as well.
- Other engine failures, hydraulic failures resulting in significant flight control system loss (or single source hydraulic remains), single remaining electrical source, unreliable airspeed resulting in manual flight with minimal instrumentation – all such failures should result in **at least** a PAN call.
- Where a PAN call has been used and inadequate support from ATC is obtained – crew could consider upgrading to a Mayday call.
- There are some countries where the use of a PAN call could create more confusion than assistance from ATC.
- Crew can always declare a Mayday during the initial stages of a NNM, then later downgrade to a PAN call.

## 5.7. Oxygen Masks

Oxygen Masks are usually donned during one of the few times during NNM operations where time is a significant factor in the successful outcome of a NNM event. This is probably why it's often poorly done in the simulator. Donning an oxygen mask is a simple procedure:

- Place your headset backwards around your neck.
- Grab the Oxygen Mask Release Levers, pull and squeeze to inflate the mask harness.
- Place the inflated oxygen harness over your head and when in place, release the release levers and ensure a comfortable fit. Breathe. Don't forget to breathe.
- Move your headset back over your ears, select Flight Interphone (consider enabling the speaker as well) on the RTP and test call "**Captain On Oxygen**". Look for a response from the other pilot.

Note that if you are not using a headset at the time, the speaker should have already been selected, but may require a significant increase in volume in order for the crew to communicate. Glasses (prescription or otherwise) are an additional complication and crew should know ahead of time how they will handle prescription glasses in conjunction with an oxygen mask. Experiment in the simulator.

Removing them successfully is slightly more complicated. When at 10,000ft Cabin Altitude with flight path and navigation established, **someone needs to go first**. Instructors don't like to see both pilots disappearing off to the sides to come off oxygen – who's flying the plane? Once the first mask is removed, the Oxygen door closed, the reset switch pushed, the second pilot can then have a go. In the sim, hang the mask on the headset hook behind you so you don't run over the tubing with the seat later on ...

## 5.8. Cabin Altitude Memory Items

There are at least a couple more points worth making about Cabin Depressurisation and potential Rapid Descent.

Firstly – note the word **potential**. Not all cabin pressurisation problems lead to Rapid Descents. Often they are controllable through a NNM checklist. It's **worth noting** that sometimes the crew that takes the aircraft unnecessarily down to 10,000 ft over the Pacific, will have just committed the flight to an overnight on an island somewhere, irrespective of whether the aircraft is successfully re-pressurised.

It's also worth noting that the memory items associated with the Cabin Altitude are a higher priority than an ATC call.

Finally, the memory item is "**Passenger Oxygen .. Push to ON and HOLD for one Second**" not "Look at the EICAS and see if PASS OXYGEN ON is showing, then move along with your life citizens." PM should backup any auto deployment by actioning the required memory item and press the switch.

PASS OXYGEN switch . . . . . Push to ON and hold for 1 second

## 5.9. NNM Checklists Complete ... EICAS Recall vs Review

It is not necessary to perform a Recall of the EICAS when NNM checklists are complete. At this point the PF will normally want to clear the EICAS to move on with the management stage of the NNM. Unless the PF wants a complete review of all NNM failures that have occurred since engine start – all that is required is an EICAS Review to facilitate clearing the EICAS messages.

### 5.10. Wake up the PM

Considering how workload intensive for the PF exercises such as TCAS RA, Windshear low to the ground and Terrain Escape exercises can be – it’s interesting how often during these exercises nothing is heard (or nothing of use anyway) from the PM. Just at the time when the PF could really use information like “**Two Hundred RAD ALT AND DESCENDING**” during a windshear exercise, the PM is focussed on the same inch square part of the PFD that has the PF’s attention, and says nothing at all. It’s worth noting that during exercises that involve the potential for ground contact (Windshear, CFIT, etc) – calling useful information is a skill that benefits from forethought, just like any other skill. Calling Rad Alt values rather than indicated Altitude tends to communicate the needs of the situation more clearly.

As the PM you’re there to assist and monitor the PF – not be caught by the same tunnel focus attention deficit problems that strike the pilot flying the aircraft. Also a call to ATC (eg “**TCAS RA**”) to let them know what’s going on is useful when circumstances permit as well.

### 5.11. Cancelling EICAS – Checklist still to complete

There should never be a situation where an EICAS message with an associated (☐) incomplete checklist is cancelled. A Captain may choose not to commence, or choose to halt a checklist – but the associated EICAS message should remain displayed.

### 5.12. Recovering from TCAS RA (or most Manual Flight NNMs)

After a TCAS RA, the PF is now (hopefully) in control of an aircraft that is in complete manual flight – including thrust. The aircraft has most likely deviated away from its previous flight path (usually either ALT, VNAV ALT or VNAV PATH) including selected speed. If you have read the comment elsewhere in this document about not throwing your aircraft at the autopilot you’ll know that the answer to this is NOT to engage the AP and hope it fixes the problem. That’s not what it’s certified for.

During and after a TCAS RA – don’t forget manual thrust is required for speed. Without appropriate manual thrust inputs either an over speed or under speed is a likely outcome – fly the aircraft.

- For the recovery, firstly verify that your altitude selector is where you want to be. If not – call for it to be corrected by the PM.
- Then call for FLCH (you’re manually flying – the switch is not yours to press). In one press, this mode will engage the auto throttle and the flight director pitch bar in the correct modes to return your vertical flight path to where it needs to be to regain your desired altitude.
- Now consider your lateral mode – do you need Hdg/Trk select or is LNAV doing the job?
- All that remains at this point is to **steer the flight director** and you can **then** engage the autopilot.

### 5.13. ECL checklist Title usage

Crews are encouraged to use the ECL in a formalised, regimented manner. Good habits practiced during times of low stress and workload transfer to periods when the workload and stress is higher.

- Call for a checklist by its full and correct title “**Engine Severe Damage Separation Left Checklist**”
- Read the checklist title and condition statement in full once the checklist is displayed on the MFD.
- Read the checklist title in full and the completing statement when a checklist is complete “**Engine Severe Damage Separation Checklist Complete Except For Deferred Items.**”

### 5.14. Flaps for Go-Around

There is a common misconception that following a Flap 20 Approach/Landing, the missed approach is flown with Flaps 5 – “**Go-Around ... Flaps 5**”

In fact Flaps 5 in the Go-Around should only be called for when specifically directed by the ECL NNM checklist, which is usually done to improve climb performance characteristics during the missed approach.

**Note:** Use flaps 20 and VREF 30 + 20 for landing. Higher approach speeds improve airplane maneuvering characteristics.

**Note:** Use flaps 20 and VREF 20 for landing and flaps 5 for go-around.

Examples where Flaps 5 is **not** called for during a go-around after a Flaps 20 approach include the following.

- **STABILIZER** : Flaps 20 is used to provide increased airflow over the tail to ensure sufficient elevator authority for landing. Flaps 20 is maintained during the Go-Around.
- **FLIGHT CONTROLS** : Flaps 20 is used to provide increased airflow over the flight controls and improve airplane manoeuvring characteristics. **Flaps 20 is maintained during the Go-Around.**

## 5.15. Communication after a NNM – who do you call?

In the simulator, we tend to play lip service to the communication requirement after a NNM event. No instructor wants to sit through an extended NITS briefing to the FM, long details to the Company or Engineering, nor an off the cuff, hesitant, convoluted and occasionally alarming PA to the passengers.

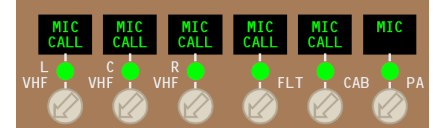

However these actions must be included in your thinking after a NNM. At least until command training, something along the lines of “**Ok now I’d call the Company ... Done**”, then “**And now I’d give the FM a NITS briefing ... Done.**” Finishing with “**Ok let’s tell the Passengers what’s going on ... Done**” meets the need.

If you need a crutch to remember who to call after a NNM – look at your primary communications device – the RTP. There’s a checklist built right into it. Look through the various possible MIC selections and analyse who you normally talk to through that channel – there’s your checklist of who you might need to talk to:

- VHF L - ATC (Distress Call, Assistance Request, Information)
- VHF C(DATA) - ACARS (Weather, Diversion Report, Other Company Reports)
- VHF R - Company, Engineering.
- FLT Intercom - Ground Engineering
- CAB - FM, Cabin Crew.
- PA - Passengers

Who to contact after a NNM will vary with the situation, as will the order in which they should be contacted and the information to be provided. Who is told what, how much is communicated, and the order in which it’s done begins with remembering to do it in the first place.

## 5.16. Dual Engine Fail/Stall – who flies?

The initial indication of a Dual Engine Fail/Stall (apart from the loss of both engines) is the reversion to standby electrical power. During those first critical 30 seconds or so, the aircraft is essentially on battery power **and only the CM1 has flight displays**. As soon as this is recognised, control should be handed over to the CM1, and CM2 should become the PM to run the memory items. It can be quite a challenge flying a 300 ton glider without easy visual reference to flight instruments.

Some displays are restored as the RAT is successfully deployed, and full electrical capability is achieved as the APU comes online. Control can then be handed back to the CM2 at the discretion of the CM1.

## 5.17. Flaps/Slat problems & Speed Reduction

Normally during the speed reduction associated with Flap/Slat extension there is no requirement to wait for Flap/Slat extension **to complete** before reducing speed. If you are at Flaps 1 and call for Flaps 5, as soon as the **5** indication is evident on the speed tape, PF will bug the speed straight away **even as the Flaps run to 5**.

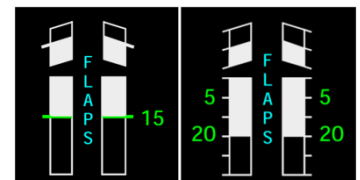

However during Flap/Slat failures that use secondary electrical extension such as **FLAPS PRIMARY, FLAP/SLAT CONTROL** or **FLAPS/SLATS DRIVE** crew are advised to **wait to reduce the airspeed until after** the requested flap/slat extension has been achieved. This is due to the slow speed at which the Flaps/Slats extend during these failures. This is particularly important during the extension of Flaps/Slats to Flaps 5, which can take significantly more time.

## 5.18. Flaps/Slat problems & Slower Deployment

Flap/Slat extension through the secondary electronic motors such as during **FLAP/SLATS PRIMARY** or **FLAP/SLAT CONTROL** comes with a NNM checklist note to plan additional time for Flap/Slat extension.

**[ ] FLAPS PRIMARY FAIL**

**Note:** Plan additional time for slower flap operation.

It’s worth quantifying the effects of slower extension. The figures here are not definitive and based on ISA conditions at Max Landing Weight, but do give an idea of the average increase in distance/time for secondary extension. Note that the times shown here under NM/NNM are cumulative. The increase in time is approximately 2 minutes, or less than half a hold. From Flaps Up to Flaps 20 takes approximately 10 track miles under secondary extension.

Flap Extension	Time (mm:ss)		
	NM	NNM	Incr
UP → Flaps 1	0:10	1:00	+ 0:50
Flaps 1 → Flaps 5	0:30	1:50	+ 0:20
Flaps 5 → Flaps 20	0:40	2:35	+ 0:45
			+ 1:55



5.19. Landing using Flaps 20 Yes/No

Often at this point during a NNM checklist, crew are observed to dive down into the FMC and select the Flap and Speed setting implied by this question in the checklist. While this is a good procedural technique for several reasons – at this point it’s still a little early.

Shortly after this question in the NNM checklist, the crew will be instructed specifically what flap setting and speed additive to use for the approach. In the case of many checklists this may not be the reference speed associated with the flap setting – as in the example shown here. **As such the proper technique is to wait for the Note advising Flap and Vref additive setting.**

19 Choose one:

- ◆ Landing using flaps 20:
  - GND PROX FLAP OVRD switch . . . . OVRD
  - Note:** Use flaps 20 and VREF 20 for landing and flaps 5 for go-around.
  - ▶▶ Go to step 20
- ◆ Landing using flaps 30 (performance permitting):
  - Note:** Use flaps 30 and VREF 30 for landing and flaps 20 for go-around.

5.20. Setting a NNM Vref – reference the ECL Notes

There are a variety of NNM’s that affect the Vref setting for approach in the FMC. Specified by the applicable ECL/QRH Note will be the flap-basis of the speed (usually either Flap 20 or Flap 30) as well as a variety of speed additives. Anytime a crew member is setting a non-standard Vref, the ECL/QRH Notes should be directly referenced to ensure the accurate setting of the Vref Flap/Speed selections – don’t rely on memory.

5.21. Slats Drive – Do We Extend the Flaps?

There is occasionally some confusion on the flight deck associated with the **SLATS DRIVE** NNM. A Slats Drive failure leaves the Slats unavailable to the crew. While not necessarily mechanically correct – you can think of this failure as the detection of an asymmetric Slat extension and therefore the FSEU has shut down the affected system to preclude further asymmetric control surface deployment. This is one reason why Alternate Flaps – which overrides the FSEU for BOTH Flaps and Slats – is specifically forbidden.

**[ ] SLATS DRIVE**

Condition: The slat drive mechanism is failed.

- 1 Do not use alternate flaps. Asymmetry and uncommanded motion protection are not provided in alternate mode.
  - Note:** Use flaps 20 and VREF 30 + 30 for landing. This provides better handling qualities when the slats are not fully extended.

Having been told they must not use Alternate Flap extension, Crew are sometimes reticent to extend Flaps through the normal Flap lever. However a visual review on the PFD of the nominated QRH NNM approach speed (Vref 30+30) confirms the need for additional flap extension for landing. The checklist also says “Use Flaps 20 and ... for landing.”

5.22. Memory Items Complete ...

When the PM has completed all the memory items associated with a QRH Checklist, the standard call “(checklist title) ... **Memory Items Complete**” is required. This call is often overlooked by crew. The call is important as it identifies the need for the PF to direct the next phase of NNM operations – Either an EICAS Review, Call for another Checklist/Memory Items, or complete the associated NNM checklist.

5.23. Fuel Jettison, Fuel To Remain – How Much?

The decision of **Fuel To Remain** when running the Fuel Jettison checklist is usually driven by the target of Maximum Landing Weight, but other considerations should also be taken into account.

**More Fuel** : Sometimes it’s worth keeping another airport within fuel range of the aircraft. If you’re looking at returning to Perth (which means considering fuel to Adelaide), if the ZFW is high (which can leave as little as 14 tons) – an overweight landing may be worth considering.

**Less Fuel** : Occasionally performance issues such as shorter runways or obstacles in the missed approach may make it worth considering a fuel load less than Maximum Landing Weight – particularly with a low ZFW. The conditions would need to be extreme however, typically for a 10 ton change in aircraft weight, runway distance improves by less than 100 meters and climb performance improves by less than 1%.

**Fuel Jettison**

Condition: Fuel jettison is needed.

- 2 Choose one:
  - ◆ FUEL TO REMAIN is acceptable:
  - ◆ FUEL TO REMAIN must be changed:



**5.24. Overriding NM Checklist Items.**

Some NNM events result in NM checklist items failing to close loop. Typical examples include Flap/Slat failures such as Flaps/Slats Drive or Flap/Slat Control. Approach and landing is flown with Flap 20. The Landing Checklist has the relevant item Flaps .... 20 – but despite the flaps being selected and indicating 20, the NM checklist Flaps items fails to complete the loop. Crew must **Item Override** in order to complete the checklist.

It's important to for crew **not** to focus on the need to override the checklist item – but instead focus on the need to verify that the checklist item has been met – in the example above, make sure the Flaps **are** at 20, before overriding the checklist item.

**5.25. Rapid Descent and Task Protection**

There is a long standing CRM principle called Task Protection. Basically the intent of this is that despite the multi tasking needs that are placed on a pilot during the complex operation of a multi-crew, automation dependant flight deck – most people can really only do one thing, very well, at a time. Allowing the quality of your current task to be degraded by commencing a second, or even third one is not good airmanship or common sense. Especially when the second and third tasks could well have waited, and the first one involves saving lives.

A case in point is the **Cabin Altitude** checklist/memory items. Once the memory items are complete and the aircraft is established in the rapid descent, the option of calling for and completing the associated checklist presents (or not), along with the other NNM event handling aspects of this failure.

In the simulator (after the adrenaline raising onset to this exercise) a period of low activity is encountered by the crew, **and the instructor**. Memory Items are complete, NNM checklist is held (or not), the aircraft is flat out descending with Speedbrake and the regular sound of Darth Vader breathing can be heard in the simulator. There's nothing to do and the crew are keen as mustard to find something. This is NOT the time to contact ATC for the weather. This is NOT the time to decide where to divert to. This is NOT the time to communicate with the cabin or passengers (although it is funny to listen to - **"Ladies and Gentlemen, PSSST PSSST, we have experienced a minor technical difficulty PSSST PSSST with the air conditioning system PSSST PSSST and are descending to ten thousand feet where PSST PSST you can all begin breathing again."**)

Protect Your Task. Your task is:

- a) Get the aircraft safely to 10,000 ft.
- b) Get yourself and fellow oxygen breathers safely off the oxygen masks so you can talk and plan effectively again.
- c) Assess the Flight Path and Navigation – are you safe? Where's the Terrain? Do you need a mini-plan?
- d) Complete the Non Normal Checklists – all of them.

Then it's time to move onwards to ATC, Cabin, Passengers, Company, etc.

It should be noted that in the worst Cabin Depressurisation and Rapid Descent (such as a door/window blowout) where the cabin altitude climbs at tens of thousand feet per minute (or more) – it's unlikely the crew will be in any condition to attempt the Cabin Altitude Checklist during the descent. It will be all they can do to breathe and concentrate on flying the aircraft as they attempt to deal with several nasty effects of high altitude flight including middle ear pain, chilling, internal pressure gas expansion and the potentially associated internal tissue trauma, decompression sickness and hypoxia. On the day – **unless as a crew you're up to it** – the checklist can wait. Fly the plane.

That covers Rapid De-Pressurisation/Rapid Descents. Not all de-pressurisations are rapid. If the rapid descent is established and if all the memory items are done – and at the direction/agreement of the PF/PM – the **Cabin Altitude** checklist **can** be called for onto the MFD. It can be run by the PM, monitored by the PF and in the very least used to back up the important memory items of the drill.

Like so many other things in Aviation, this is a valid technique as long as you don't mess it up ...

**5.26. Dispatch with a NNM**

When dispatching with a defect under the DDG, no information is provided to crew as to how the NNM should be handled after start when EICAS detects the fault. One common response by the crew is to override any NNM checklist – this is usually the wrong response.

Run the NNM checklist. Any Notes generated as a result will gather for the Recall/Notes part of the Arrival Briefing/Descent Checklist. Usually these notes are relevant to the operation – because the equipment is actually failed and needs to be taken into account during subsequent flight operations.

ATA 27 777 Dispatch Deviations Guide Section 2

27-02-08 Thrust Asymmetry Compensation (TAC) Function			
Interval	Installed	Required	Procedure
C	1	0	

PLACARD  
As appropriate

### 5.27. Fire Engine – Use Your Own Clock

Once that first fire bottle has been fired, the intent of the **FIRE ENG** checklist memory item is for the PM to start the onside clock to time for 30 seconds in preparation for the second bottle. Bringing up the  **FIRE ENG** checklist at this point to use the inbuilt timer instead of your own clock is against the operating philosophy of the EICAS/ECL. In the event that there are multiple checklist or the timer doesn't function it also exposes the NNM to inaccurate timing.

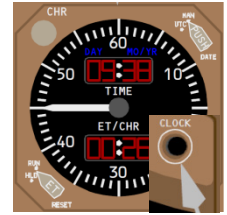

### 5.28. Cabin Altitude Checklist (Silently)

A technique commonly taught to crews regarding the Cabin Altitude/Rapid Descent NNM Event is for the PM to display the Cabin Altitude Checklist after the Memory Items were completed and then silently verify the completion of the memory component of the NNM checklist during early stages of the Rapid Descent. This technique is not in accordance with Boeing NNM checklist philosophy.

Some justification for this technique can seem to be found in the QRH Checklist

The last paragraph (highlighted) can be read to endorse this technique of verifying the completion of the memory items prior to the PF calling for the Cabin Altitude Checklist.

When a non-normal situation occurs, at the direction of the pilot flying, both crewmembers do all memory items in their areas of responsibility without delay.

The pilot flying calls for the checklist when:

- the flight path is under control
- the airplane is not in a critical phase of flight (such as takeoff or landing)
- all memory items are complete.

For checklists with memory items, the pilot monitoring first verifies that each memory item has been done. The checklist is normally read aloud during this verification. The pilot flying does not need to respond except for items that are not in agreement with the checklist. With the electronic checklist, items that are complete (green) do not need to be read or verified. The item numbers do not need to be read.

Instructions (CI 2.4).

In fact, this paragraph must be read in the context of those before it. In sequence the events are:

- a) Non Normal Event Occurs.
- b) At the direction of the PF, both crew members complete the memory items in their area of responsibility without delay.
- c) When flight path is under control; clear of a critical phase of flight; memory items complete – PF calls for the NNM Checklist associated with the completed Memory Items.

At this point, the paragraph in question becomes applicable. The NNM checklist is commenced at the request of the PF. If this checklist includes Memory Items – these will be at the beginning of the checklist and if completed (as they should be at this point), the Memory Items will be one of the following two types:

- Closed Loop – PM does not need to read these reference items.
- Open Loop, Action Performed – PM must read them, check them off as done. PF does not need to respond.

In the event the PM is operating the paper QRH, all items will be read aloud and verified complete by the PM, with no involvement required by the PF, assuming all Memory Items were completed correctly.

So this paragraph does not endorse the silent running of the Cabin Altitude checklist after the completion of the Memory Items, but addresses the normal commencement of a NNM checklist that begins with Memory Items.

### 5.29. Fuel Jettison & Fuel Imbalance

After the loss of an engine at heavy weight, crews will often be confronted with the EICAS **FUEL IMBALANCE** advisory, having already commenced fuel jettison to reduce weight for landing. The Fuel Imbalance will occur after the Centre Tank has been emptied by the jettison (and the remaining engine).

The FCOM/FCTM contains no limitation on simultaneously running both procedures. The **FUEL IMBALANCE** message itself is not inhibited during fuel jettison. Inherently many Captains are distrustful of running two fuel NNM's at the same time – perhaps for good reason (many of them have flown Airbus).

The issue of the need to combine fuel jettison with the fuel balancing procedure is rarely encountered in the simulator, in spite of the fact that it should be a common event. Instead the jettison is commenced normally, but then expedited down by the instructor towards the final jettison fuel figure – a process which automatically balances the fuel load. Often the unwanted fuel is dumped by the instructor without use of the jettison system at all, once the crew identify the heavy aircraft weight. With fuel jettison from maximum takeoff weight to maximum landing weight taking over 40 minutes, instructor intervention to expedite is not surprising.

In fact the question is **not** “Should you run the Fuel Imbalance Checklist while engaged in Fuel Jettison?” but in fact “Should you choose NOT to run the Fuel Imbalance Checklist during Fuel Jettison.”

Choosing NOT to run a NNM checklist is always within the purview of the Captain – but the implications of not running that checklist should be mitigated (see SOP Amplification : EICAS/ECL, **How NOT to do a Checklist.**)

If the crew choose not to run the Fuel Imbalance checklist, then potentially they could be accepting a 6-8 ton fuel imbalance by the time the jettison is stops, with less than 5.2 tons in the main tank providing fuel to the remaining engine. Potentially the Overweight Landing Checklist will still be required, as the **FUEL JETTISON MAIN** system failure occurs when fuel in one of the main tanks reaches jettison standpipe level (5.2 tons) before the fuel jettison target fuel load is reached.

A Captain can always choose not to do, or to halt a NNM checklist. In this case the best method may be to commence the Fuel Imbalance checklist, verifying there is no fuel leak, then halt the checklist prior to the commencement of the actual fuel balance procedure. Complete the fuel jettison, then return to the Fuel Imbalance checklist and proceed.

On the other hand, the Fuel Imbalance checklist works well enough during fuel jettison – as long as nothing else goes wrong. The main tank jettison pumps take no part in the balancing of fuel, they feed into a separate manifold. As long as the jettison nozzles are open, fuel from the centre tank takes the path of least resistance out the jettison valves. When jettison is complete the pumps cease operation and the centre tank isolation valves are closed automatically.

The point of this section is to explain the issues associated with Fuel Imbalance combined with Fuel Jettison – and to point out that this is another of those times where if the crew chooses NOT to do something – it should be NOT done, properly.

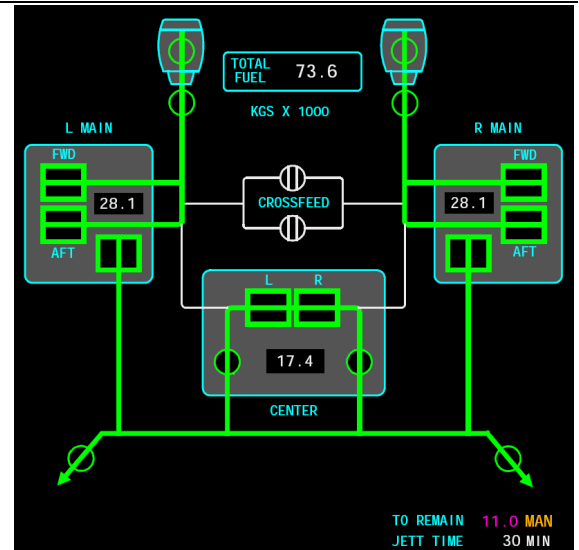

Fuel imbalance between main tanks for taxi, takeoff and landing must not exceed:

- 3000 lb (1360 kg) when total main tank fuel exceeds 123,000 lb (55,791 kg).
- 4500 lb (2041 kg) when total main tank fuel is less than or equal to 90,000 lb (40,823 kg).
- A linear interpolation between 4500 lb (2041 kg) and 3000 lb (1360 kg) when main tank fuel is greater than 90,000 lb (40,823 kg) and less than or equal to 123,000 lb (55,791 kg), respectively.

6. Non Normals on the Ground

6.1. **Keep the Big Picture**

A common error during NNM's on the ground is for the flight crew to forget the outside world. Whether this is an engine start abnormal, a pack failure after pushback, or something more serious, there is a tendency to forget the ground engineer connected below, ATC and the fact that the aircraft is probably blocking a taxi way while the NNM is being actioned. Keep the ground engineer and ATC in the loop, maintain the big picture during ground NNM's.

6.2. **Confirmation is not required**

When running Memory Items or Checklists that use the word "Confirm" during NNM's on the ground – confirmation of the intended action is NOT required. The lack of confirmation on the ground is specifically useful during time critical memory items such as Engine or Cargo Fires, or other failures which are leading towards a Passenger Evacuation requirement. PM gets on with the Checklist/Memory Items in an expeditious, if careful manner.

The word "Confirm" is added to checklist items when both crewmembers must verbally agree before action is taken. During an inflight non-normal situation, verbal confirmation is required for:

- an autothrottle arm switch
- an engine thrust lever
- a fuel control switch
- an engine or APU fire switch, or a cargo fire arm switch
- a generator drive disconnect switch.

QRH CI 2.5

Note however that this does not necessarily preclude the PM from choosing to confirm with the PF (or CM2 confirming with CM1) irreversible actions during NNM events on the ground **that are not time critical**. Such a confirmation could be considered good airmanship when time is not of the essence and achieving the aim of a NNM Checklist/Memory Item accurately **as a crew** is a higher priority.

6.3. **To Stop or Not to Stop ...**

When a NNM event occurs on the ground, one of the first considerations should be whether or not to stop the aircraft. Irrespective of which pilot is PF, this is usually the call of the Captain (CM1). CM1 should seriously consider stopping the aircraft if the NNM event is likely to lead to:

- Calling for Checklist Memory Items.
- NNM Checklists that will require the attention of both pilots (Cautions/Warnings?)
- Any potential for a Passenger Evacuation.

In particular – if there is any potential for a Passenger Evacuation – CM1 should take control, bring the aircraft to a halt, set the Parking Brake, (decide whether to) stand the Cabin Crew to Attention – and call for the appropriate Checklist/Memory Items.

This control handover stems from the requirement for **the CM1 to be the PF during the Evacuation Checklist**, and a recommendation to avoid changing PF/PM during Checklist/Memory Items.

6.4. **Who has the Radio?**

When calling for Checklist/Memory Items on the ground, CM1 has a brief opportunity to take the radio for the duration of the NNM. During events such as Fires, Rejected Takeoff and Passenger Evacuation the radio as a potential source of information can be determinative on the outcome of the NNM. Direct access to that information can expedite the CM1's decision process and ensure the accurate flow of information. CM1 taking the radio also leaves CM2 to run the NNM checklist/memory items without distraction.

6.5. **Passenger Evacuation & Paper QRH Usage**

During the Passenger Evacuation Checklist the removal of AC power sources requires the use of the Paper QRH (no ECL), which is made more difficult (at night, or anytime in the sim) by the removal of AC power and therefore the majority of flight deck light sources.

Additionally the Passenger Evacuation checklist requires action items of the CM1, both at the beginning and in the middle of the checklist. CRM is best served when both crew have access to the checklist during the procedure.

Because the Dome Light remains functional through to the end of the checklist, the best solution tends to be for the CM2 to place the QRH on top of the lower MFD, turn on the Storm light switch and run the checklist from there. In this position the checklist remains illuminated by the Dome light and both crew can review the QRH checklist as it is actioned.

Evacuation		
Condition: An evacuation is needed.		
1	Parking brake . . . . .	Set C
2	OUTFLOW VALVE switches (both) . . . . .	MAN F/O
3	OUTFLOW VALVE MANUAL switches (both) . . . . .	Push to OPEN and hold until the outflow valve displays show fully open to depressurize the airplane F/O
4	FUEL CONTROL switches (both) . . . . .	CUTOFF C
5	Advise the cabin to evacuate.	C
6	Advise the tower.	F/O
7	Engine fire switches (both) . . . . .	Pull F/O
8	APU fire switch . . . . .	Override and pull F/O
9	If an engine or APU fire warning light is illuminated:	
	Illuminated fire switch . . . . .	Rotate to the stop and hold for 1 second F/O

6.6. If you're going to Stop ...

Anytime the aircraft is stopped on the ground with NNM's in progress, actions are taken based on **Pre-Flight Areas of Responsibility (AOR)**.

This does not mean the FCOM CM1-PF/CM2-PM AOR – the QRH CI is referring to the FCOM Pre-Flight Scan Flows actioned by CM1/CM2 during flight deck setup.

**Basically – when actioning switches during a NNM on the ground with the aircraft stopped – switches and knobs are activated during the Checklist/Memory Items by the pilot that pre-flighted them before engine start. So:**

- Auto Throttle Arm Switches – CM1
- Thrust Levers – CM1
- Fuel Control Switches – CM1
- Engine Fire Switches – CM2

The QRH identifies C or F/O on the QRH Passenger Evacuation checklist, confirming the pre-flight areas of responsibilities for the relevant checklist actions.

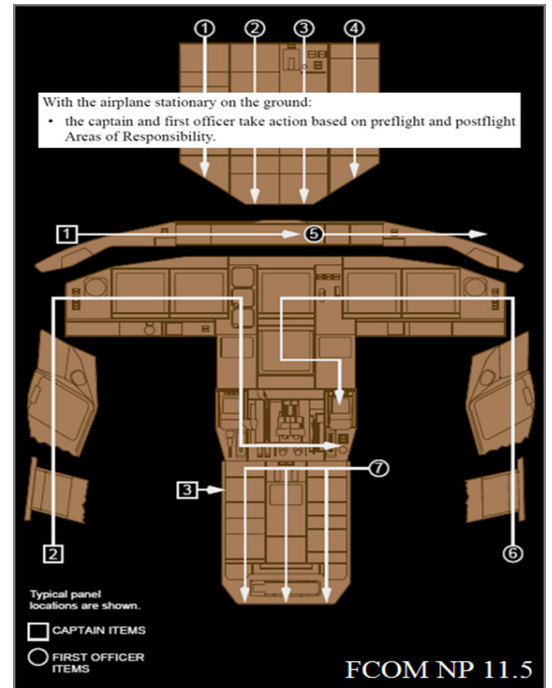

6.7. Passenger Evacuation & Clearing the Runway

The issue of whether to clear the runway prior to a passenger evacuation (as part of a rejected takeoff) is hotly debated amongst trainers and crew alike. The benefits of clearing the runway usually revolve around leaving the runway open for airport operations and potentially turning the aircraft into wind in the event of engine/APU/cabin fire.

One of the dangers of leaving the runway, particularly when a fire is involved, is the potential to expose the aircraft to a crosswind that could burn across the fuselage and turn an engine fire into an airframe fire. At some airfields where taxi ways are narrow the aircraft can be left in a position where access to an engine fire by fire services can be significantly restricted. Airfields that include taxi ways with bridges across roads and waterways can cause similar issues with fires on the ground.

Generally the conservative approach is considered to be to bring the aircraft to a halt on the centreline of the runway and commence the required NNM procedures. Any turn off the runway must be undertaken in full knowledge of the prevailing wind and ideally briefed as part of the emergency briefing, and potentially updated as the aircraft approaches the runway.

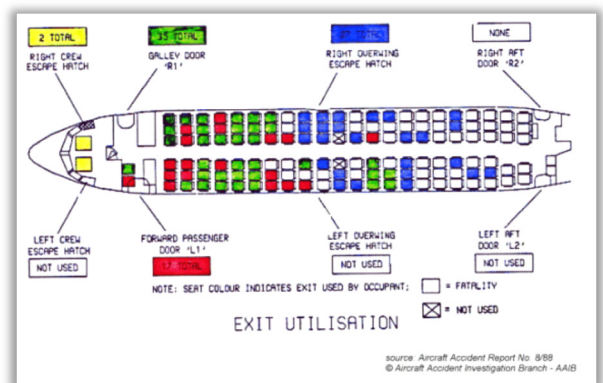

A similar issue exists after a high speed rejected takeoff where passenger evacuation is not required. Typically there is a limited time period before the potential for a brake fire must be considered. While clearing the runway might well be considered a friendly action to airport operations – doing so onto a narrow taxi way where fire services can't access the brakes needs to be a higher consideration.

6.8. Landing NNMs & Passenger Evacuation

When landing with an abnormal that might lead to a passenger evacuation, whether forewarned and pre-briefed such as a previously existing un-extinguishable engine fire, or late notice such as an APU fire on short final, it is generally recommended that the CM1 take control during at some point, **bring the aircraft to a stop, set the parking brake and stand the crew to stations** "This is the Captain ... Cabin Crew To Your Stations." From this point on CM2 is the PM and will run the appropriate Recalls/Checklists and CM1 retains oversight of the NNM and may also choose to take communications as well (6.4 Who has the Radio?).



## 6.9. Rejected Take Off – Give the CM1 a Chance

One common error observed during a rejected takeoff (or a landing NNM that potentially requires a passenger evacuation) is the CM2's need to push into the NNM cycle prior to the CM1 completing the current task of **executing** the RTO.

Typically the CM1 will rejected the takeoff, perform the required actions, along with the CM2 calls, verifications and ATC call. As the aircraft comes to a halt, the CM1 stows the reversers and sets the parking brake, CM2 will launch into the assessment phase – calling the EICAS or analysing the engine failure.

At this point the CM1's focus needs to be task protection. The CM1's task is to bring the aircraft safely to a halt, set the Parking Brake and decide whether to stand the crew attention to the doors, and execute that decision. Only then should the CM1 allow the NNM to move forwards and ask the CM2 for an assessment. CM1's need to focus on task to completion, so CM2's need to be careful distracting CM1's during this critical phase.



## 7. Engine Failure After Takeoff (EFATO)

### 7.1. Engine Failure After Takeoff (EFATO) – Pitch Attitude

Students are often taught during engine out training to target a pitch attitude of 8° to 11° after takeoff rotation. This is because a pitch attitude significantly more than this usually results in a subsequent loss of airspeed to V<sub>2</sub> (or below) and a necessarily correcting pitch change to recover. Typically engine failures in the simulator are practiced at maximum landing weight with de-rated thrust.

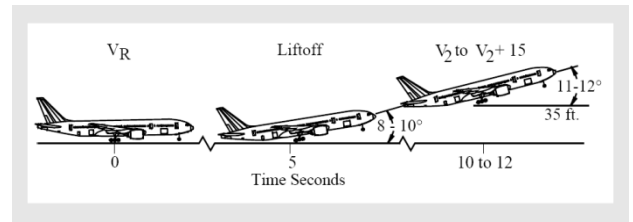

It is common (in the simulator) to see a student pitch to about 12° after an EFATO which initially results in a stable speed – but then as the Landing Gear retracts the speed decays and a pitch attitude at or below 8° is usually required (with an associated loss of climb performance) to recover. Typically this recovery manoeuvre is necessary just as the student has commenced trimming the aircraft – hence the admonishment to aim for 10°.

However the Boeing FCTM is quite specific in this area. It should be noted that Boeing FCTM guidance is intended to cover the full operating envelope of the aircraft – from lower weight takeoffs with high thrust settings, to higher weight takeoffs with de-rated thrust. Engine out takeoff rotation should have the following characteristics.

- Flight director pitch commands are not used for rotation.
- Rotation at ½° per second less than normal (i.e. 1½° to 2° per second)
- **Towards** a pitch attitude 2° to 3° below the normal all engine target (i.e. 12° to 13° Nose Up)
- Liftoff should be achieved in approximately 5 seconds (1 second more than that for All Engine) with a typical liftoff attitude of 9°
- Once Airborne, adjust pitch attitude to maintain desired speed (V<sub>2</sub> to V<sub>2</sub>+15 knots) – note that shortly after airborne this is the guidance the Flight Directors should provide.

As such, it is incorrect to teach (or target) a pitch attitude of 8° to 9° for EFATO - not the least of which because this may delay liftoff. The best advice regarding this issue is to follow the FCTM rotation guidance. Then once airborne, fly the aircraft until the gear is fully retracted and the pitch attitude and speed stable, before commencing a distraction such as trimming. Beware of the flight director indications until you have achieved this stability – continue to fly attitude and airspeed until fully airborne and stable. **At this point the Flight Directors are providing guidance to achieve V<sub>2</sub> to V<sub>2</sub>+15 and are providing appropriate guidance.** Note that if the aircraft is allowed to slow to less than V<sub>2</sub> the Flight Directors may well command a descent to recover the speed.

### 7.2. Engine Out, High Weight, High Altitude, Turning

During an EFATO, the aircraft's angle of bank at low speed will be limited by the AFDS. This protection keeps the aircraft clear of the increase in stall speed during turns, as well as providing some degree of compliance with the design of EOSIDs which require an angle of bank of not more than 15° (still air)

**Note:** The AFDS limits the bank angle to 15° until V<sub>2</sub> + 10 knots to maintain at least adequate maneuver margin. The bank angle limit increases to 25° by V<sub>2</sub> + 20 knots if LNAV is engaged, or when HDG SEL or TRK SEL is engaged with the bank limit in AUTO.

However this protection is not available once the aircraft has commenced acceleration. V Australia EOSIDs that require turning typically schedule the turn once the aircraft has reached Engine Out Acceleration Height. Crew need to be aware that the combination of large angles of bank (both Heading/Track Select and LNAV will command angles of bank well in excess of 15°) and the usual practice of Flap retraction 20 knots below minimum flap manoeuvring speed can result in a low speed excursion, including EICAS AIRSPEED LOW and EICAS AUTOPILOT. This is of course exacerbated when manoeuvring engine out in marginal performance conditions (high weight, high density altitude). This condition can be corrected by either delaying acceleration until the engine out manoeuvring is complete, or limiting the angle of bank.

### 7.3. TO2 ... Engine Failure ... TOGA ... V<sub>mc</sub> A/G?

At light weights and low takeoff speeds utilising a fixed thrust derate such as TO2, the application of full TO thrust after an engine failure can theoretically place the aircraft at risk owing to the likely proximity of VMCG/VMCA. Since TO2 is based on a fixed de-rate (25%) the takeoff speeds are selected against a reduced maximum TO2 thrust VMCG. Thus on the ground it is at least theoretically possible to advance asymmetric thrust to the maximum (TO) and compromise VMCG. Since thrust loss prior to V<sub>1</sub> should result in a rejected takeoff, the risk only presents at and above V<sub>1</sub> speed.

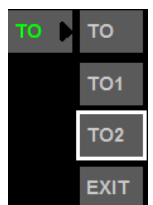

Meanwhile the V<sub>2</sub> chosen by OPT at any Assumed/Fixed thrust setting provides the minimum regulatory margin over full TO thrust VMCA. As such full TOGA thrust is available anytime after V<sub>2</sub> is achieved irrespective of previous derate.

7.4. AICC – Announce, Identify, Confirm, Commence

During training a model is used during engine failure sequences to lend structure to one of the few non normals that doesn't depend solely on the EICAS messages to diagnose, and is trained most often during a critical phase of flight – this model is AICC, used for engine malfunctions.

AICC is a four phase solution to calling, analysing, confirming and actioning the indications associated with an engine failure during takeoff (or any time). **Announce** (the problem); **Identify** (the specific failure); **Confirm** (the identification); **Commence** (the appropriate procedure).

Note that while the following discussion applies AICC directly to an engine failure at a critical point during takeoff – AICC can in fact be applicable any time an engine malfunction occurs. Nothing contained within this procedure should be seen to diminish the authority of the Captain to exercise judgement in altering the procedure as required to assure a safe outcome when dealing with the situation.

Announce

PM : "Engine Problem."  
PF : "Check."

An engine malfunction is identified through a variety of means. At the point of detection, a clear and unambiguous statement is made by the first pilot to observe an indication of the problem, typically the PM. The **Announce** phase is typically prior to 400 feet at which point the PM needs to communicate clearly that there is a problem, but not enter into any analysis of the failure.

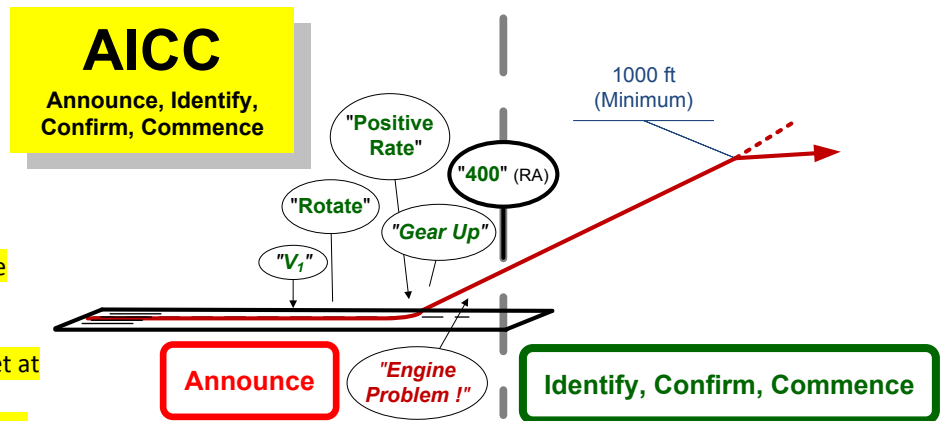

- EICAS Warning/Caution/Message
- Abnormal Noise/Vibration
- Abnormal aircraft or engine handling/operating characteristics.

At this point of the failure the **Announce** step **does not** attempt to perform any analysis of the failure, nor does it necessarily identify the engine affected. The primary intent of **Announce** is to ensure situational awareness of the problem by both pilots. Note the use of the word "**Problem**" rather than "**Failure**" which could be confused with reading the EICAS.

The Announce call itself for an engine malfunction can be either the generic "**Engine Problem**" or the failure specific EICAS Message:

- "**EICAS ENGINE FAIL / ENGINE THRUST / FIRE ENGINE / (LEFT/RIGHT) \***" – Engine Problem (as displayed on EICAS)
- "**Engine Problem**" – Various Engine Problems (as identified by EICAS/Engine/Thrust/Airframe indications)

\* Note that our SOPs permit the crew to call the EICAS message related to an engine failure/fire (including the Left/Right identifier) at any time, even shortly after takeoff prior to being asked by the PF to identify the failure – see **5.4 Takeoff Non Normal Calls**, EICAS/ECL Guide for a discussion on this.

This is a break from the tradition of not identifying an engine failure as left/right until an analysis has been completed. This is based upon the introduction of EICAS into our flight decks. **Any failure that does not include a specific Left/Right EICAS message should not involve initially calling which engine shows the malfunction.** It is also acceptable for a crew member (as a matter of personal preference) to decline early identification and opt to choose to call "**Engine Problem**" rather than "**EICAS ENG FAIL LEFT**" prior to the Identify phase of AICC.

## Identify

PF : "Identify the Failure."

PM : "EICAS ENGINE FAIL LEFT and TAC. We have Airframe Vibration – Recommend ENGINE SEVERE DAMAGE SEPARATION LEFT Memory Items."

Once aircraft control and flight path is established the PF calls for the PM to "Identify The Failure". This commences a brief process to identify which of the NNM Engine Malfunction checklists is appropriate.

This process should commence after flight control is established, after AP engagement, after 400 ft, after the PF has considered any immediate engine out procedure (EOP) navigation requirement. The **Identify** process consists of:

- Calling relevant displayed EICAS Messages.
- (Unusual) Airframe Vibration assessment.
- (Unusual) Engine Instrument Indications (if required).

With the current Boeing engine failure analysis paradigm, most failures now do not require a detailed engine instrument indication assessment. Caution should be exercised in identifying failures that are not clearly identified by an EICAS message. Refer to **7.11 Engine Failure Handling – a Paradigm Shift** and **7.13 Engine Failure Analysis**

The PM should verbalise the high points of the analysis and state the assessment in terms of the recommended checklist/memory items.

- "EICAS ENG FAIL LEFT, no Airframe Vibration ... Recommend ENG FAIL LEFT."
- "EICAS ENG THRUST LEFT, we have some Airframe Vibration ... Recommend ENG LIM SURGE/STALL LEFT Memory Items"
- "EICAS ENG FAIL LEFT, TAC. There's Airframe Vibration ... Recommend ENG SEV DAM/SEP Memory Items"
- "EICAS FIRE ENG LEFT"

## Confirm

PF : "Confirmed ..." ; or

PF : " (Name the Identified Failure) Confirmed ... "

It is now the PF's task to confirm the PM's assessed failure identification. PF's primary task is always to fly the aircraft, but the confirmation of the PM's assessment should be completed without delay. Apart from confirming the diagnosis of the failure itself – the Left/Right Engine aspect of the failure is verified by the PF as well.

There's always the possibility that the PF does not agree. In which case an appropriate response may be as follows, although the provision of additional information to guide the PM's assessment may be advisable.

PF : " Negative, Identify the Failure. "

The Confirm stage leads directly into the **Commence** stage, initiated by the PF.

## Commence

PF : " Confirmed ... (Commence) ENGINE SEVERE DAMAGE/SEPARATION (L/R) Memory Items."

If the PF confirms the assessment of the failure, the PF can immediately initiate the recommended Checklist/Memory Items as appropriate. Memory Items are commenced in accordance with documented V Australia SOP's (See SOP EICAS/ECL Guide).

PF should continue provide attention to the flight path and navigation requirement of flying the aircraft. Often action needs to be taken during the NNM Commence phase relating to the 3rd segment – acceleration and configuration. Refer to **7.10 Acceleration, Configuration and Memory Items** for a discussion on acceleration during memory items.

7.5. Fly The Aircraft – What does it mean?

This axiom has been over used in Aviation. In the training environment – and during line operations when things are getting a little tense – you’ll hear these words used as an admonishment, a reminder, as encouragement, as criticism, as a standardisation. But when the student hears it – will he know what it means? How do you implement Fly The Aircraft practically?

In the context of this discussion (EFATO) – Fly The Aircraft is the physical control of the aircraft during and after the point of thrust loss associated with an engine malfunction. It refers to the control inputs (Rudder, Aileron, Elevator and Thrust Lever) actioned by the PF to achieve **Attitude** (in all three axis) and **Performance**. In actuality – it’s the achievement that’s all important. You set Attitude and Thrust to achieve **Performance**.

What performance? Without clear criteria in the mind of the PF, Fly The Aircraft degenerates into a high minded philosophical concept with little real application to an Engine Failure. After an engine failure, prior to engaging the AP, the PF needs to achieve the following Attitude/Performance:

**Pitch** : About 10°      **Roll** : Wings Level      **Yaw** : Slip/Skid Centered      **Thrust** : TOGA/Sufficient.

- It is incorrect to teach a specific pitch attitude for engine out flight (see 7.1 Engine Failure After Takeoff (EFATO) – Pitch Attitude). The intent of pitching the aircraft is to attain and maintain speed – V2+15 by certification. That said, students need something to aim for initially and once the aircraft is airborne and climbing; 10° works well enough under most conditions. Much higher than 10° between 50ft and 200ft certainly makes life difficult as energy/airspeed suffers during the gear retraction cycle.
- The correct lateral/longitudinal attitude during engine out flight is a neutral control wheel deflection with a small angle of bank towards the live engine – this is what the PF should be aiming for during flight/trimming. That said, there’s nothing wrong with starting with wings level/ball centred initially, and once the aircraft has settled down, optimum performance through wing down flight should be attained.

Prior to AP engagement at >200 ft AGL, the PF should make a positive check that Power + Attitude = Performance is correct – then engage the AP (with or without trimming) and move onto the next phase of the NNM.

7.6. EFATO – Trimming

Boeing specifically delineate the rudder trim as in the PF’s area of responsibility. As such the technique of the PF asking the PM to set a specific number or trim units is clearly against the intent of the Boeing SOP, and not encouraged by V Australia SOPs.

This technique comes generally from an observation during EFATO simulator training of the PF reaching for the rudder trim shortly after rotation and either (a) focussing on the trim to the detriment of aircraft flight path control; or (b) trimming in the wrong direction.

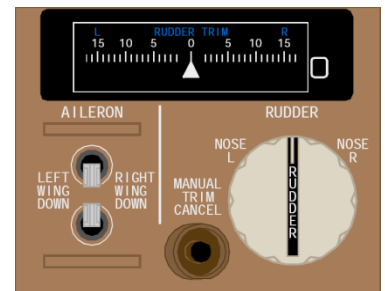

This issue is usually the result of unfamiliarity with the rudder trim control (a training issue); or the tendency of the PF to trim too early after an engine failure.

The solution to this is usually to delay trimming until the aircraft is stabilised, in trim (sufficient rudder deflection to centralise the control column) and climbing adequately. Trimming prior to this point (and prior to the completion of the gear retraction cycle) is usually premature.

A suggested technique is to first concentrate on flying the aircraft to 200 ft RA. This is the earliest point that the AP can be engaged – if the aircraft is under control, climbing adequately and in trim (rudder input sufficient to result in zero aileron input); the AP **should** be engaged. Then make a conscious decision to review the need for trimming (has the TAC failed?) and deliberately establish a trim setting appropriate to the rudder demand. Typically by 200 ft the EICAS inhibit has ended, and while it would be inappropriate to start running Checklists at this stage, a quick look can confirm the status of the TAC **if there’s any doubt, rather than peremptorily releasing the rudder.**

There are a number of home-brew techniques for trimming such as using Fuel Flow on the operating engine as a numeric guide (14 tons/hour needs 14 units) which generally work well enough – but essentially sufficient trim achieves control wheel neutral with a slight angle of bank and small displacement of the slip indicator towards the live engine.

7.7. In Flight Engine Start

In flight engine start is usually attempted subsequent to an engine failure where the engine has been assessed damage free and the need to re-start the engine has been established. This usually takes place as part of the ENG FAIL checklist, although the Engine In-Flight Start checklist also exists for this purpose.

The engine in flight start procedure raises some issues, particularly for new Captains. Although Autostart will be used to start the engine, the in flight EGT start limit will not be applied by the Autostart system. In fact the EGT is allowed to increase to an un-specified value between the Start and time limited Takeoff EGT limits.

As such the decision about whether to allow a high EGT during the start should be made prior to commencing the start, and the Fuel Control switch should be guarded until the start is complete. Therefore Captains may want to evaluate who should fly the aircraft, and who should start the engine. In either method – a quick discussion to review the impending start is a good practice to follow.

Consideration could be given to using the lower MFD for the secondary engine instruments to assist in the start – typically the NNM checklist on the lower MFD forces a compacted engine display which may be less than ideal for an in flight start on a miss-behaving engine. The ECL could be run on the PM’s ND. Another alternative would be to briefly review the compacted engine display with a view to the expected indications during the start.

7.8. Thrust Lever Usage while Engine Out

During engine out flight, some crew prefer to keep both levers up in parallel while others keep the failed thrust lever at idle. Boeing provide no specific guidance on this, although it could be said that all the engine failure checklists require the thrust lever of the failed engine set to Idle, then do not refer to it again.

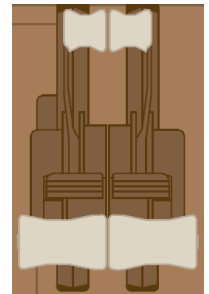

The significant dis-advantage of not keeping the failed thrust lever in the idle position is that it can promote confusion on the flight deck between the operating vs failed engine. Workload is increased during Autothrottle operation as the failed thrust lever must be continually matched. One advantage of keeping the failed thrust lever in the idle position is that it gives you somewhere to rest your arm while following through Autothrottle operation of the thrust lever.

7.9. Engine Out – When do we Accelerate?

Most airlines construct their engine out procedures to be flown to completion at a maximum speed of V<sub>2</sub>+25 and an angle of bank of 15°. Thus irrespective of the published engine out acceleration altitude, acceleration is delayed until after engine out manoeuvring is complete to ensure the flight path is contained within design area. Then there’s V.

V Australia Engine Out Acceleration altitudes are selected to ensure terrain clearance during any engine out manoeuvring. As such it is not required to delay acceleration because of a promulgated EOSID. Any requirement to do so will be clearly annotated on the EOSID for the associated runway.

7.10. Acceleration, Configuration and Memory Items

It is not unusual for memory items associated with an engine fire/failure to carry past the acceleration height. The issue of 3<sup>rd</sup> segment acceleration during the running of checklist memory items can be a contentious one.

Typically there are three options:

- Use VNAV Speed Intervention (or TOGA) to extend the second segment – ideally before the speed increase is selected by VNAV at the Engine Out Accel Height.
- Allow acceleration to commence, but delay configuring (raising the flap) until the memory items are complete. The aircraft will accelerate to the current Flap setting limit speed less 5 knots, then continue climbing.
- Allow acceleration to commence and re-configure on schedule, raising flap at the same time as Memory Items are actioned. Priority is typically given to appropriately actioning the Memory Items over the Flap Lever.

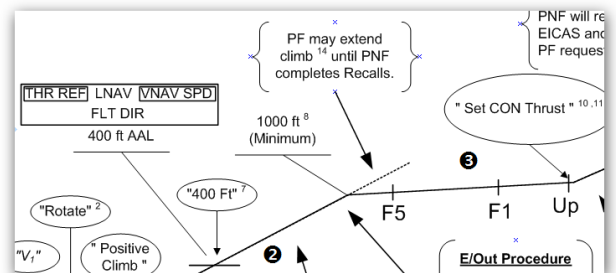

All of these options carry risk factors whether they be obstacle clearance, task prioritisation/workload issues or engine thrust time limit related. Crew must understand the risks of the these procedures for dealing with acceleration during Memory Items and manage the risk appropriately. Decide early what your response will be and consider briefing it.

### 7.11. Engine Failure Handling – a Paradigm Shift

A re-design of the Boeing 777 QRH in 2007 brought a paradigm shift in engine malfunction handling on the 777. One of the drivers behind these changes was to reduce any un-necessary requirement to action memory items at low altitude after an engine failure during takeoff.

This change manifests in a few key areas:

- The analysis of an engine failure for the purpose of checklist selection reflects on the failure indications **at the time of the analysis** – not the time of the failure. This means that if there was a loud bang, airframe vibration, and/or engine limit exceedences during the failure – only those aspects of the failure that persist through to the point of the analysis are considered.
- Engine Damage is not indicated by N1 or N2 Seizure; only by the conditions stated in the Engine Severe Damage/Separation checklist – which essentially comes down to Airframe Vibration.

These two factors result in sweeping changes in engine malfunction handling. In all but a few extreme engine failure scenarios, memory items (that is the Lim/Surge/Stall or Severe Damage/Separation) are not required.

Another significant result of this change is that whereas previously a “damaged” engine (N1 or N2 seizure, engine vibration during the failure, etc) would result in the Engine Fire Switch pulled at low altitude, under the new paradigm the Fire Switch will not be pulled at all.

Boeing and GE have been consulted extensively regarding both the changes to the 777 QRH and the engine fire switch. Boeing’s response confirmed the desire to minimise the use of memory items at low altitude and the reduced requirement to run either the Lim/Surge/Stall or the Severe Damage/Separation checklists for failures that result in engine speed below idle.

#### 1 Engine Fire Switches

In (normal position, mechanically locked) – unlocks automatically for a fire warning, or when the FUEL CONTROL switch is in CUTOFF.

Out –

- arms both engine fire extinguishers
- closes the associated engine and spar fuel valves
- closes the associated engine bleed air valves
- trips the associated engine generators off
- shuts off hydraulic fluid to the associated engine–driven hydraulic pump
- depressurizes the associated engine–driven hydraulic pump
- removes power to the thrust reverser isolation valve.

### 7.12. Engine Fire on Takeoff – Early Acceleration & Climb Thrust

A commonly observed event in the simulator during an **FIRE ENG** on takeoff is the early acceleration of the aircraft - often due to an early two-engine altitude capture no longer justified by the remaining single engine performance. The use of FLCH SPD by the crew in a recovery attempt results in setting CLB (or CON) with the potential inability of the aircraft to accelerate for flap retraction - is also a common error associated with this scenario.

The solution to this is usually to revert to basics – trigger the TOGA switches to return the FMA to basic modes, then review the need for another lateral mode (LNAV? TRK SEL?). If acceleration is required (prior to ALT capture) the PF may need to increase the speed on the MCP.



7.13. Engine Failure Analysis

When an engine malfunction occurs during any phase of flight, the crew are required to assess the malfunction in order to identify the specific checklist required for the NNM prior to calling for the checklist/memory items.

Engine problems can be detected through EICAS messages such as **ENG THRUST** or **ENG FAIL**. Alternatively the engine problem could well involve unusual engine indications with/without external stimuli such as noise, airframe vibration, flames in the inlet exhaust, lack of response to thrust lever movement and various degrees of asymmetric flight. In any case – the intent of the **Analysis** is to identify which of the engine failure checklists is the most appropriate response to the malfunction.

**Checklist Priority**

Using the EICAS checklist prioritisation philosophy (See SOP EICAS/ECL document) and common sense, crew should start at the top of the priority list, eliminating checklists until the appropriate response is selected.

- **FIRE ENG** (displayed on EICAS) Memory Items
- **ENG SVR DAMAGE/SEP** (un-annunciated) Memory Items
- **ENG LIM/SURGE/STALL** (un-annunciated) Memory Items
- **ENG FAIL** (displayed on EICAS) Checklist

**An Analysis Flowchart**

All failure analysis commences with the EICAS. Please note that the following technique and flowchart come from documentation review, discussion and experience – but not from Boeing.

**FIRE ENG** is analysed using standard EICAS/ECL procedures. If it's not a FIRE ENG ...

**Engine Separation** (leading to  **ENG SVR DAMAGE/SEP**) can be less clear, but typically results in total thrust loss, missing engine instrument indications and engine service related failures such as hydraulic/electrical system events as well as probably the loss of the TAC.

Further analysis is facilitated by answering the following two questions, in turn **based on indications at the time of the analysis** (not the **initial** failure):

**Q1 : Is the Engine Failed ??** (EICAS  **ENG FAIL L/R** )

**Q2 : Do we have (unusual) Airframe Vibration ??**

These two questions will lead to one of the three remaining Engine Malfunction Checklist/Memory Items.

Note that during this analysis phase crew are **not** looking for a limit exceedance, surge/stalling, lack of response to thrust lever movement, engine flames or asymmetric flight, etc.

Assessment of these conditions are not necessary at this point - these indications lead **into** the analysis process, and aren't now required as part of it.

If the engine is still running, the Airframe Vibration assessment allows for Minimal Vibration leading to the Eng Lim/Surge/ Stall checklist/memory items. The crew need to ask themselves what they want to achieve – a malfunctioning engine at idle thrust, or a malfunctioning engine shut down/secured. The answer will depend on the severity of the failure. If the engine/airframe combination has significant airframe vibration – crew are likely to shut it down (Sev Dam/Sep) rather than leave the engine running at idle thrust. Note the option of commencing the Lim/Surge/Stall checklist/memory items and upgrading to the Severe/Damage Separation remains valid.

The PM should summarise the indications that lead to the specific checklist, stating the title of the recommended checklist as the result of the analysis - arming the PF with the ability to confirm the failure identification and call for the agreed checklist/memory items. See **7.4 AICC – Announce, Identify, Confirm, Commence**

**Eng Svr Damage/Sep L, R**

Condition: One or more of these occur:

- Airframe vibrations with abnormal engine indications
- Engine separation

**Eng Lim/Surge/Stall L, R**

Condition: One or more of these occur:

- Engine indications are abnormal
- Engine indications are quickly nearing or show an exceedance
- Abnormal engine noises are heard, possibly with airframe vibration
- There is no response to thrust lever movement
- Flames in the engine inlet or exhaust are reported

**[ ] ENG FAIL L, R**

Condition: Engine speed is below idle.

Objective: To attempt engine restart if needed, or configure for single engine operation.

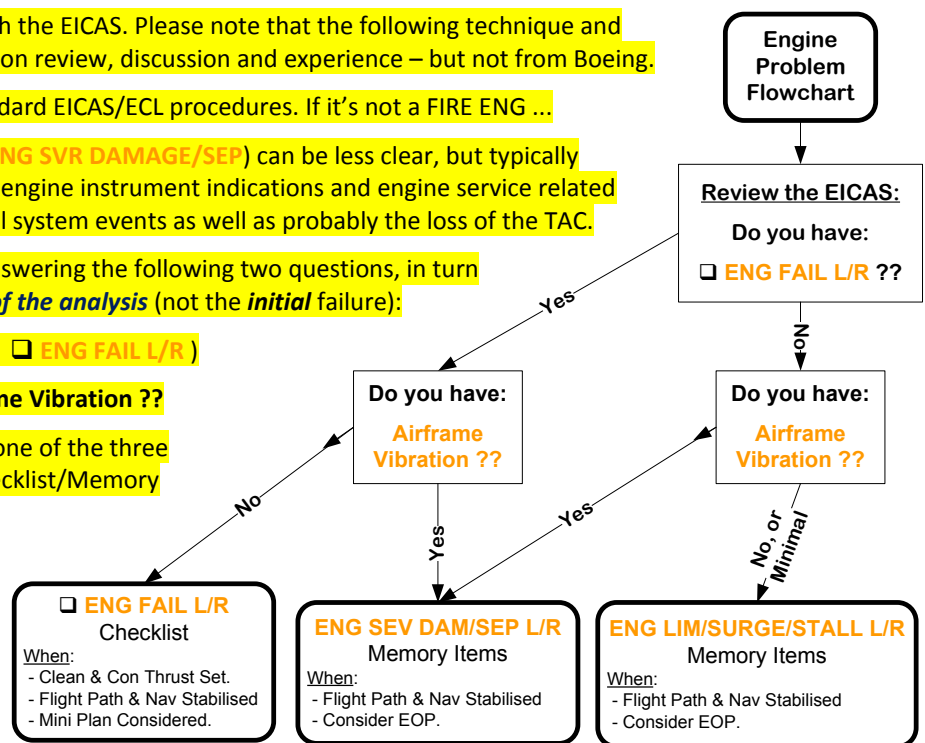

7.14. Engine In flight Re-Starts – Damaged Engines

Re-lighting an engine in flight contains some potential pitfalls that are worthy of discussion. Refer to the EICAS/ECL SOP Guide chapter on In-flight Relight Envelope for a discussion on the AFM assured-start operating envelope.

One discussion point is the result of a recent change in the Boeing QRH with respect to engine in flight starts. Traditionally the QRH would advise that re-start may be attempted if **no indications of engine damage were present**. This has now been reduced to confirming **no abnormal airframe vibration**. Based on this, a re-start could be attempted in the event of a frozen N1/N2, zero oil pressure and a high engine vibration indication (without associated airframe vibration). Boeing’s response to queries on this change is as follows:

- At low airspeeds typically associated with engine out operation, the N1/N2 indication is not guaranteed and thus should not preclude a start attempt (if needed). An in flight re-start attempt with a genuinely seized core (or fan) will only result in a failed start attempt. The N2 rotor drives the accessories which can drag the windmilling N2 indication below reliable indication.
- Similarly, Low Oil Pressure may be a normal indication with a failed engine and low forward airspeed. Very low oil quantity (with accompanying low oil pressure) may be an adequate reason to preclude a re-start attempt, but this would depend on the perceived need to re-start the engine.
- EICAS vibration indication alone does not necessarily indicate engine damage. Associated airframe vibration would be required, which should have lead the crew to the Engine Severe Damage/Separation checklist instead without the option of a re-start.

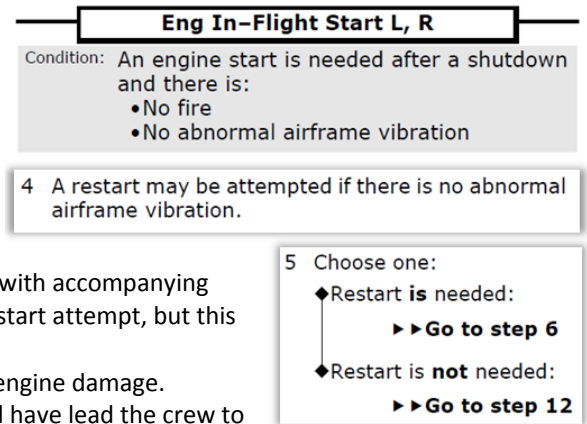

In summary - the minimum requirement prior to attempting a re-start is that the engine is indicating neither current Limit/Surge/Stall or Engine Severe Damage/Separation conditions; **no abnormal airframe vibration**. From this point onwards, only the need to restart the engine is required.

7.15. CLB/CON Thrust during EFATO Acceleration

Occasionally during an EFATO sequence, CLB/CON thrust is unintentionally (or intentionally) set as the engine thrust limit. This can occur because the engine failure/shutdown occurs after VNAV engages CLB thrust or because FLCH is used inappropriately during the EFATO sequence. A similar situation can occur during engine out go-arounds.

There are various options to correct this situation:

- If CLB thrust set, the MCP CLB/CON switch should set CON thrust;
- The default FMC INIT REF page at this point will be THRUST LIM, so pressing INIT REF ... TO will set TO/GA thrust;
- **The TOGA switches will clear all de-rates as well as returning the aircraft to basic modes.**

The CLB/CON switch is a simple selection, but in the case of high weight or high de-rate takeoff’s, CON will not be enough thrust to guarantee adequate acceleration/terrain clearance. While TO/GA thrust can be set using the FMC CDU, this is usually an inappropriate time for FMC manipulation; mistakes are easily made.

The use of FLCH is regularly selected crew – FLCH is usually a save-all mode that sets and engages A/Thr and correct AFDS pitch mode anomalies as well. The first issue is that FLCH will set CON thrust (see previous). The second is that the aircraft will now be accelerating through the third segment in a mode that was never intended for the purpose. The 80/20 distribution of thrust for speed/altitude change may not meet the certification requirements of third segment acceleration (which is designed to be essentially level).

The correct response is usually the TOGA switches to re-engage TO/GA modes and TO/GA thrust. Lateral mode selection (LNAV? TRK SEL?) needs consideration as well as potentially a speed selection to either delay or continue acceleration.

During an EFATO sequence or an engine out go-around without VNAV engaged, CON thrust should not be selected by the PF until the Flaps have been selected up and minimum clean speed (Up) has been achieved.

7.16. Engine Out Procedures – AIT

Each V Australia EOSID contains a documented EOP from the runway to MSA - in this case to track 340° to 5<sup>D</sup> ML VOR, then turn right and track 130°, climb to MSA. AIT stands for After Initial Turn and refers to the path to be followed should the engine failure occur after the initial turn on the SID, in this case track direct to EPPing NDB and climb to MSA.

**Engine Failure Procedure:**  
TRK 340. At 5.0 DME ML RT TRK 130.  
AIT: TRK to EPP CLB MSA.

### 7.17. Engine Failure on Takeoff – Overview Diagram

This diagram overviews a sequence profile for Engine related NNM's during takeoff and must not be extrapolated across the spectrum of other takeoff NNMs or other phases of flight – refer to Boeing EICAS/ECL/NNM handling in the FCTM/ QRH.

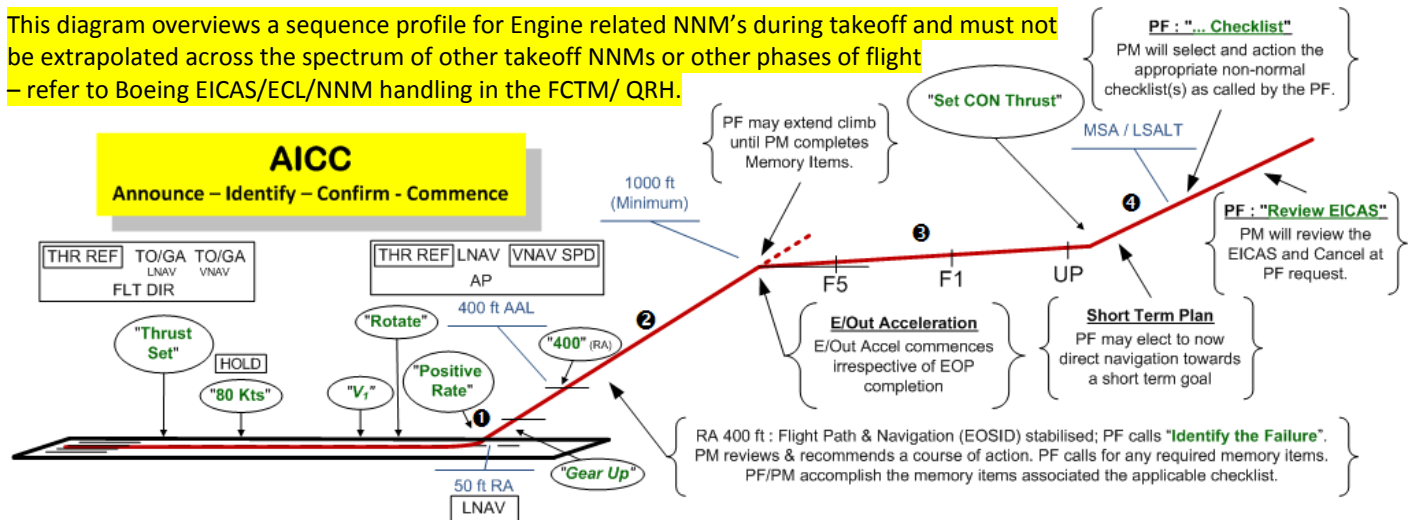

- Between A/Thr **HOLD** and liftoff, only manual advancement of thrust is available. Once airborne the TO/GA Switches are available. It is acceptable to push the thrust levers forward below 400ft to increase thrust and still preserve LNAV/VNAV engagement. The A/Thr re-engages at 400 ft AAL if VNAV engages and re-sets any derated takeoff thrust.
- PM may call "Engine Problem" or the relevant EICAS message during takeoff – however nothing should prejudice the requirement for "Rotate" and "Positive Rate" from the PM.
- If performance is marginal and PF is struggling with flight control, PM can consider a call of "TOGA Thrust Available" at the appropriate time.
- If the PF is observed to be trimming with TAC available, a call of "TAC is Available" can help.
- AP engagement is strongly encouraged above 200 ft with flight path and performance stabilised. The aircraft does not have to be trimmed, but **should be In Trim** before AP engagement.
- Apart from rudder pedal feedback, TAC failure will be indicated by EICAS after the takeoff inhibit ends (approx 200 ft). If the aircraft is accidentally trimmed with TAC engaged, use of the Trim Cancel Switch will remove **pilot** trim inputs.
- The correct technique for manual trimming achieves Control Wheel Neutral, with a slight angle of bank towards the live engine.
- TOGA Thrust should applied as required by flight path and performance, by the PF. PM may suggest as appropriate. Prior to 400 ft AAL, the thrust levers can be moved forwards by the PF without TOGA Switch use.
- If TOGA lateral tracking is incorrect, one option is to steer the required track and re-select TOGA. Note this will deselect LNAV/VNAV arming/engagement.
- The "400"ft (RA) call is a **lateral awareness call** from normal ops standard calls. During EFATO this call serves to remind the PF to consider the EOSID and the APFD modes required to follow them – such as runway track/track select when the normal departure LNAV/SID requires otherwise.
- EOSID Navigation takes priority over failure assessment and checklist/memory items.
- The AFDS limits bank angle engine out (HDG/TRK SEL in AUTO) to 15° until V<sub>2</sub>+10 kts, then increases to 25° at V<sub>2</sub>+20 – unless in LNAV. If full manoeuvring is required in HDG/TRK Select, the bank angle selector must be utilised to increase the limiting bank angle.
- Engine out turns are based on still air, speed V<sub>2</sub>+15, and a maximum angle of bank of 15° while at minimum speed (the EOSID may specifically vary these). The EOSID is commenced irrespective of achieving engine out acceleration height, depending on EOSID specification.
- Engine Out Acceleration takes place at a minimum of 1000 ft AAL, or higher as specified by takeoff performance calculation. Second Segment climb can be extended in order to complete checklist memory items – see **7.10 Acceleration, Configuration and Memory Items**

- The second segment (2) is extended using Speed Intervention. Remember to cancel Speed Intervention when Memory Items are complete.
- TOGA thrust is limited to 10 minutes from EGT above 1050°C (CON Thrust). Also Max N1 %110.5 and N2 %121.0
- If the 10 minute thrust limit is reached, CON thrust can be selected in order to avoid exceeding certified thrust limits, terrain permitting.
- CON thrust is not set until Flaps are **selected Up** and V<sub>REF</sub> 30+80 (Up speed) reached. In basic modes use **FLCH** or A/Thr **CLB/CON** switch.
- The "Short Term Plan" is used to manage short term flight path and navigation requirements between Clean/CON and completion of the NNM checklists. Typically the short term plan will conform to that briefed during the Departure Briefing and cover items such as immediate tracking/altitude requirements, any need to hold/jettison and general intent of destination. NNM checklists may well change these items.

#### Below 400 Feet.

No actions other than:

- Raising the Gear
- Silencing any Warning
- Application of TOGA

Possible Exceptions include:

- Reverser Unlocked
- Engine Failures that may ...

*Affect the Continued Safety of the Flight.*

#### PF Actions/Responsibilities:

##### 1. Fly the Aircraft :

- ↳ Engage Auto Pilot as available
- ↳ TAC Inoperative - Trim Aircraft

##### 2. Gear Up

} Actions to Ensure

##### 3. TOGA Thrust

} Required Performance

#### PM Actions/Responsibilities:

##### 1. Monitor PF

- 2. Gear / Cancel Warnings / TOGA
- 3. Call of TOGA / TAC Status

#### Checklists Complete...

##### Further Considerations (FORDEC)

- In Flight Relight Considerations
  - \* "No abnormal airframe vibration"
  - \*  ENG FAIL Checklist Actioned
- Weather for Return/Diversion
- Call Company
- Brief FM & Pax (NITS)
- Dangerous Goods (NOTOC)
- Fuel Jettison (MALW / Fuel for ALTN)
- Overweight Landing Checklist?
- Landing Configuration
- Flap 20 for Go Around Climb Limit ?
- Landing Distance
- FMS (Eng Out & Hold / Return Approach)
- Recall ... Notes ... Arrival Briefing
- Descent & Approach Checklists.

## 8. Pre-Flight

### 8.1. Pre-Flight Briefing – Management

The complexity and volume of the pre-flight paperwork of a long haul international flight, coupled with the time pressure that is typical of the pre-flight regime must be managed effectively by the flight crew.

Captains new to augmented operations must also learn to manage the effective and efficient use of the relief crew during pre-flight. Use of relief crew outside of in-flight relief duties should be done in a manner that decreases the workload on the operating crew without introducing opportunities for error, nor reducing the situational awareness of the Operating Crew – irrespective of the rank of the relief crew available.

Captains are encouraged to allow the First Officer to run the pre-flight briefing when the FO is PF.

#### Crew/Task Management

Captains can utilise the available relief crew to divide the tasks required during pre-flight briefing in order to expedite and improve the process. As long as the crew present are qualified, there are no limitations associated with assigning one relief crew member the Weather and another the NOTAMS, as the operating crew review and discuss the OFP together. However a summary of the pertinent information must be reviewed by the crew as a whole once each crew member has completed their task.

It's important for Captains to realise that when Briefing components are delegated – particularly to non-operating crew members – the task is being delegated but not the responsibility. Captains must ensure that as the result of the pre-flight documentation review they have a sufficiently detailed knowledge of the OFP, Weather and NOTAMS to be able to certify as to the legality of flight dispatch and make informed decisions on aspects such as the fuel load, choice of alternates, etc.

Likewise relief crew must appreciate that when reviewing NOTAMS/Weather for the operating crew, this task is unlikely to be re-checked prior to dispatch and as such the operational responsibility implied is significant. Relief crew who are delegated the task of reviewing NOTAMS and Weather are not being asked to ensure the legality of dispatch – they are being tasked with gathering information relevant to the flight necessary to inform and therefore enable the Captain to assess the legalities of the flight, as well as other aspects such as the fuel load.

Typically the NOTAMS and Weather are delegated to different crew members, despite the need to analyse both of these information sets against each other simultaneously to gain a full overview when making dispatch related decisions. Thus the individual crew reviewing these segments of the information must allow for the possibilities of the other when summarising the results.

For example ...

- If Destination Melbourne Runway 27 is closed by NOTAM for the arrival, this might not seem crucial (“not a show stopper”) because RW16/34 remains available and is the primary runway of use in any case – but if the wind was a strong westerly near the crosswind limit of the aircraft and the crossing runway closed - extra fuel might well be a consideration. In any event – closure of a useable runway at an operational airport should be a must know for the Captain, irrespective of other runways that are available.
- If the VOR at the Alternate Avalon was unserviceable, this might not be considered relevant to dispatch because the Avalon ILS would be the primary approach aid in any case. But if the wind in Melbourne is a northerly, this coupled with the current lack of RNAV approach approval requires a circling approach. Couple this with some average weather against the high alternate circling minima requirement and suddenly Avalon looks like a poor choice as an alternate. Particularly if thrown into the mix is a re-clearance flight plan resulting in minimum contingency fuel.

**LAX-SYD**

**VA2**

**VH-VOZ**

**16 May 2009 (Local)**

**Briefing Document Generated: 17 MAY 2009 0438 UTC**

Document Contents

1. Cover Sheet
2. Dispatch Message
3. Flight Plan
4. Intam
5. Pilot Weather Briefing
6. Route Plot
7. SigWX Imagery
8. Notam Briefing

*(Additional text from the document image: CAPTAIN, OPERATIONS, SECURITY CHECK, DISPATCH MESSAGE, FLIGHT PLAN, INTAM, PILOT WEATHER BRIEFING, ROUTE PLOT, SIGWX IMAGERY, NOTAM BRIEFING, etc.)*



**8.2. Pre-Flight Briefing – Expediting**

Often there is limited time before departure for a complete review of the flight briefing package on long haul and particularly ultra long haul flights. Even with an augmented crew (*sometimes especially with an augmented crew*) time is tight and this process needs to be reduced to the minimum necessary for legal departure. Typically this means:

- **Weather and NOTAMS for Departure** (including **Takeoff Alternate** if required), **Destination, Destination Alternate(s)** and **EDTO Alternates**.
- **Area & FIR NOTAMS for Departure, Destination and First Flight Hour.**

When time is tight, these are the minimum items required to ensure legal dispatch of the aircraft.

**Weather Forecast Review**

Reviewing airfield weather can be expedited by having in mind a set of wind, cloud and visibility criteria used to avoid a detailed assessment of a forecast. If the forecast does not involve Wind of more than 30 knots; significant cloud below 1000 ft; visibility below 5km/3sm then the forecast does not need to be read in detail. These values allow for dispatch with an EDTO airfield that has one runway and a non-precision approach. This should cover all cases other than perhaps a one way runway with a strong tailwind component.

If a first glance at the weather forecast reveals phenomena below these minima’s then a quick look at the validity period, or presence of a leading TEMPO or INTER often allows the rest of the forecast to be skipped. Other than the alternate; destination and final EDTO airfields – ULH flights generally have lots of fuel.

**NOTAM Review**

Similarly, speed reading NOTAMS is typically not a process of looking for applicable NOTAMS, but rather a process of eliminating non-applicable ones. NOTAMS that can quickly be eliminated include:

- NOTAMS outside the validity period of your flight/flight segment;
- NOTAMS that concern Runways/Approaches/Procedures the V Australia 777 isn’t authorised for;
- NOTAMS that don’t directly affect dispatch legality – such as taxi ways; parking stands; STARS at departure; SIDS at enroute, destination and alternate airports; Airport works that don’t directly affect Runway lengths; etc.

Assuming the minimum pre-flight briefing, NOTAMS need to be reviewed in detail shortly after top of climb as the enroute and destination and destination alternate airfields come into range – prior to this only the legalities of the operation need to be considered when time is short.

**8.3. Aircraft Power Up**

REF : FCOM SP 6.2 ELECTRICAL POWER UP

Aircraft power up is a seldom used procedure. Rather than actioning from memory, or by some form of off the cuff pre-flight scan – this process should be done using the specific Supplementary Procedure in the Boeing FCOM.

Electrical Power Up	
The following procedure is accomplished to permit safe application of electrical power.	
BATTERY switch .....	ON
C1 and C2 PRIMARY pump switches .....	OFF
DEMAND pump selectors .....	OFF

If you arrive the aircraft after a power down (such as LAX) and it’s clear the power up procedure was not done correctly

(eg: **Battery** Switch still off) – speak to the engineer and/or verify the rest of the Electrical Power Up procedure.

**8.4. EICAS Recall during Pre-Flight**

During the initial pre-flight, the CM2/1 should complete an EICAS Recall (not a Review) to clear the EICAS. Ideally this should consist of cancelling all displayed EICAS messages until the EICAS is clear. Then the Secondary Engine pages should be displayed. The first press of the EICAS Recall/Cancel switch will:

- Display the word “Recall” under the EICAS NNM Message list area;
- Display the first page of the EICAS Message List
- Display any existing engine exceedences on either the primary engine instruments or the secondary engine display.

Further presses of the EICAS Recall/Cancel switch will display any subsequent pages of EICAS Messages, until the display is blank. At this point the secondary engine indications can be cleared off the lower MFD.

**8.5. Pre-flight : Keep the EICAS Clear**

During the pre-flight, CM2 should conduct an EICAS recall and review the displayed messages as part of the panel flow. Once satisfied the messages are appropriate, they should be cancelled **and the EICAS kept clear**. Subsequent display of EICAS messages should be reviewed, considered and cancelled. The practice of keeping all EICAS messages displayed and having them disappear one by one as the engines are started is not recommended.

### 8.6. Starting the APU – Start, Release to ON

The 777 APU Start Switch has a known history for releasing back to the OFF position after it is started in a fairly casual manner by crew. The technique is to position the switch from OFF through ON to START, Pause, then Release to ON – ensuring the inbuilt spring does not allow the switch to flick through to OFF.

### 8.7. TFC on the ND during pre-flight

It is easy to miss the fact that TFC (or TCAS OFF) is not displayed on the ND during pre-flight. Crews have been observed to complete a simulator session without any TFC display right up until the point where a TCAS RA activation during descent brings the TFC popup for both pilots.

There are several techniques employed by crews to trap this human factors weakness in the aircraft. Some involve a pre thought out scan of the ND during pre-flight (working left to down to Right – ARPT, WXR/TERR, TFC, VOR-L, GPS, VOR-R, then DATA, POS).

The TFC selection is probably best trapped by the CM2 during the Before Start Flow. As a general airmanship principle switches and controls in the aircraft should not be actioned without verification. Based on this principle, when the CM2 selects 'TCAS RA' on the centre console during the after start flow, CM2 should look up at both ND's to ensure that TFC has replaced the TCAS OFF annunciation.

### 8.8. Pre-Flight Checklist – Altimeters

The Altimeters check in the Pre-Flight Checklist is a cross check of the barometric subscale setting – not the altitude reading itself. Thus the proper response to the blank line on this checklist is the current subscale setting, not the indicated altitude.

The ADIRU takes air data from two sets of balanced sources, and produces a single output to both PFD's – as such there should never be a difference in altimeter readout (assuming the correct subscale is set) between the two PFD's, unless a system failure is present (NAV AIR DATA SYS) or an Air Data/Attitude Source Select switch has been selected.

Note that the Integrated Standby Flight Display sources air data and attitude information from its own independent sources, not the ADIRU/SAARU systems.

### 8.9. Seating – Eye Position

It is very common for crew to have poor seating position in the aircraft. Boeing provides very specific guidelines on correct seating position in the FCOM – crew should be familiar with the procedure.

Typically this seating position maximises the pilot's view over the glare shield while maintaining good eye line with the instrument panel. The seating position proscribed is most crucial at the minima in poor visual conditions where clear sight of the approach lights can determine the outcome of the approach, as well as in the landing flare where a poor seating position can mean the pilot has to stretch upwards to see the end of the runway in the last moments of the landing.

Once in the proscribed position, if you feel like you're sitting with your head on the roof and your nose on the window and you're not at all comfortable – you probably have it right.

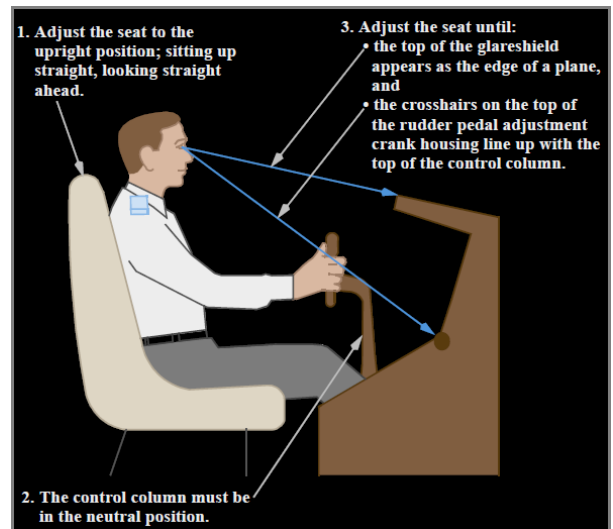

### 8.10. Defuelling

If you are ever required to de-fuel the aircraft, best of luck to you.

- Typically defueling pressure may well only be provided by the aircraft pumps only. As such the rate is approximately 80kg/min (includes APU usage).
- Countries with extensive domestic operations (such as Australia) have local regulations that do not permit the mixing of international and domestic fuel. This means the availability of a "sucking" defueling truck may be limited.
- A1, Maintenance Procedures Manuals and Local Regulations should be carefully consulted because defueling with passengers onboard can be prohibited by some authorities.



### 8.11. Revising the Standby Fuel Figure (NOT)

Before pre-flight the Ground Handling Agent (GHA) provides the airport refuelling personnel a Standby Fuel Figure (3 tons below OFF Fuel Required) to which the aircraft is to be initially fuelled.

**When providing the Refuel Record Form to engineering/refueller – Flight Crew should avoid providing a Standby Fuel figure different to this, unless a lower one is required because of early notification of a significant ZFW drop.** This will allow for a gross error check of the standby fuel figure and reduce refueller workload as detailed below.

Refuelling personnel will arrive at the aircraft, prepare the refuelling equipment, connect to the aircraft and establish a refuelling configuration based on the GHA nominated 3 ton below figure. This figure is established through the Integrated Refuelling Panel in the Left Wing, which has to be accessed through a lifting platform.

If the pilots then subsequently provide a revised figure, the refueller has to re-visit the refuelling panel, often to adjust the intended 3 ton below figure by a few hundred Kg. Unless final ramp fuel is going to be less than the GHA nominated figure – this revision to the Standby figure is un-necessary, resulting in an increase in workload and another opportunity for error in the refuelling of the aircraft.

**Essentially : The Standby Figure provided on the Refuel Record Form should only differ from the 3 ton below OFP figure provided by Ops when this figure is likely to be more than Final Ramp Fuel.**

DEP FUEL ORDER	
kg x 1000	
STAND BY	31.1
FINAL	28.1

Since this usually means a drop in Ramp Fuel in excess of 3 tons (reduction in ZFW of over 7 tons) it shouldn't happen very often.

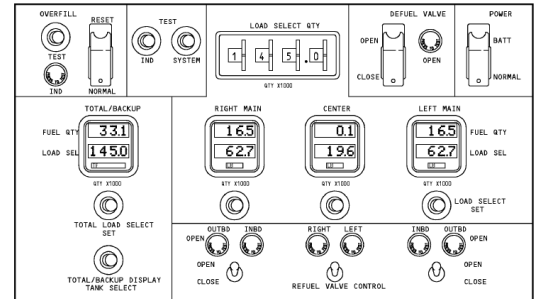

### 8.12. OPT and Takeoff Performance – Lessons from the Industry

In January 2011 the Australian ATSB released a [safety report](#) into Takeoff performance calculation and entry errors. This report details 31 accidents/incidents from Australia and internationally that involved takeoff performance calculation/entry errors along with the analysis and benefits of hindsight from these occurrences.

#### Change and Distraction

One of the major threats applicable to our operation identified in this report is **Change in Conditions**. Whether a runway change, aircraft weight change, or some other requirement forcing a re-calculation and re-entering of performance data – having followed a robust set of SOPs to achieve an accurate takeoff calculation, crew procedures must not be allowed to break down subsequently into a casual update of the “changed” information. The takeoff data re-calculation must be subject to the stringent SOP crosscheck and data entry procedural flow of the first solution.

While we are at least as subject to change as any other airline, we are also clearly subject to **Distraction** during the pre-flight phase. The words included in this section of the ATSB report include Task experience/recency, Time pressure, Distractions, Incorrect task information, High Workload, Task completion pressure, Preoccupation, and Fatigue – all should be familiar to the pilots of our ULH flight operation.

The following are some of the features of our SOPs which seek to eliminate the common errors associated with takeoff performance calculation errors, and must be protected during the busy, pressured pre-flight environment.

#### Independent Laptop/Pilot cross check

The completely independent cross check with two laptops and two pilots is manifest in our SOPs. Crew should not skimp on the check, subjecting both the source data (Load sheet, ATIS) and solution (OPT, FMC) to this check. When performance calculations must be re-calculated due to changes – the complete procedure should be repeated.

#### Laptop as the Source for CDU Data Entry

The SOPs require that the data entered by the CM1 into the FMC CDU comes directly from the (validated, crosschecked) CM2 laptop.

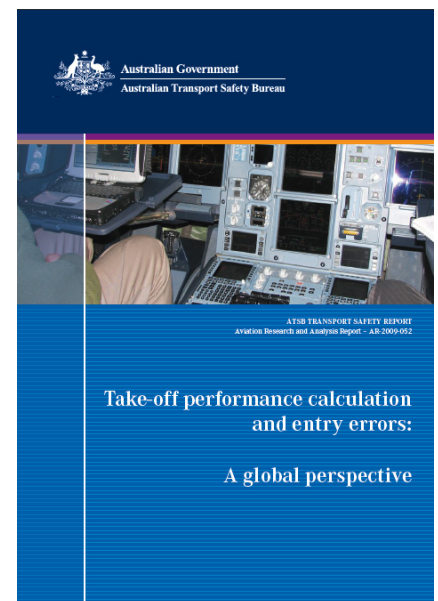

8.13. OPT Usage – A Practical Application

SOPs mandate a number of requirements on OPT usage – such as an independent cross check requirement, operating crew involvement, etc – prior to using OPT figures operationally on the flight deck. What the SOPs don't cover particularly well is the practical implementation of the two OPT installations, who does what, when and how the cross check is performed as part of the ebb and flow of the pre-flight regime. What follows is a suggested implementation – the circumstances of actual use will be up to each Captain to dictate on the flight deck, and may need to be modified to suit the timing/data availability requirements of each departure.

Like all SOPs, OPT procedures techniques are based on a two crew operation, then altered where practical to benefit from augmented crew operations. As much as possible, augmented crew operations should streamline and reduce workload, without compromising the situational awareness of the operating crew when it comes to OPT usage.

In the most basic sense, there is only one crucial (ie: operational) set of OPT calculations – the last one. While several iterations are often run during pre-flight, all of these can be performed by operating or relief crew – in the end SOP OPT usage comes down to a single calculation completed just prior to FMC data entry, which is cross checked against a separate OPT installation/calculation prior to entry. Thus OPT SOPs also come down to this single moment prior to FMC data entry.

A two crew operation would require both the Captain and First Officer to complete their own solution and cross check. From an airmanship point of view, both operating crew should have the full knowledge of the data used and the solution itself that only really comes with running the calculation yourself.

Load sheet Checked – Final FMC Takeoff Data Entry.

Once the load sheet has been verified, the final takeoff performance data can be entered into the FMC. Irrespective of what checks/calcs may have been done prior – when the load sheet has been checked the Captain has one OPT, the First Officer has the other.

With final weights entered and completed solutions in front of them both, one pilot will take the lead and proceed together to verbally cross check the OPT installation against LIDO (runway distance); the OFP (validity dates); and the other pilot's solution (data entered and solution result).

One pilot will read out the entirety of this cross check which consists of:

- 1) OPT vs LIDO Runway TORA (ARPT INFO).
- 2) OPT vs OFP Version Check (Version).
- 3) Runway/Atmospheric Data (Airport, Runway, Intersection, ATIS Data).
- 4) Aircraft Configuration Selections (Flaps, Thrust, Air-conditioning, Anti Ice).
- 5) Aircraft Weight.
- 6) Calculation Solution (Runway, Thrust Fixed De-Rate/N1, ATM, FRH, Flap, V-Speeds and VREF 30 and Takeoff Weight).
- 7) Engine Out SID.

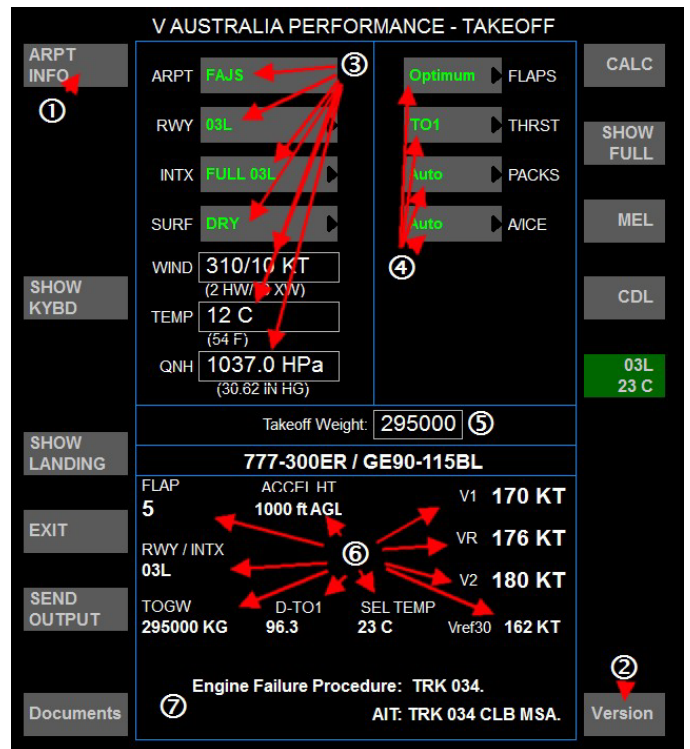

Ideally this check is completed immediately prior to data entry. Note that a useful way for the CM1 to call the Calculation Solution (6+7) is to read it out as written onto the OFP. This provides an effective structure that covers all the items and is easy for the CM2 to document on the OFP.

RWY	THRST	ATM	FRH	FLAP	V1	VR	V2	VREF30	TOGW
RW34L	TO1/96.9%	46°	1000	15	170	176	181	179	344.5
EOSID									
TRK 340° ATM L5.0° RT TRK 130° AIT: TRK TO EPP & HOLD									

Don't skip on the items of the cross check – read it all out and ensure the other pilot verifies the cross check. Between the potential for OPT to produce up to 8 solutions (Full and ATM for 4 runway lengths) as well as the possibility of altering flap required for only slight changes in wind/weight etc – the only valid cross check is the complete one.

#### 8.14. OPT Independent Cross Check – The Next Level

The SOPs require an independent crosscheck of the OPT solution that is to be used operationally. The reasons for this are clear – there is a long established history of issues associated with the Man/Machine interface and takeoff performance calculation – essentially garbage in / garbage out. When takeoff performance is calculated by computer pilots (especially those new to the aircraft) are removed from the “feel” of takeoff performance and are ill-equipped to subject OPT results to reasonableness/gross error cross checks. Thus it becomes crucial that a series of cross checks are included in OPT use. Many of these are built into the SOPs – but the Independent Cross Check is where it all begins.

**The concept of Independent Cross Check is not just a procedure however – it’s code of practice that can and should be applied to all aspects of OPT data entry / solution calculation.**

Consider the following weak points with respect to OPT data entry. As much as you might embrace the concept of an independent OPT cross check at the end – are you falling victim to the following holes in the Swiss cheese?

- During pre-flight, CM2 tunes the ATIS and writes it down on the flight plan. The CM1 arrives back from the walk around and uses the OFP ATIS for data entry into the OPT. At this point the concept of independent data cross check breaks down against the single source data on the ATIS – most notably Wind, Temperature, Pressure, etc.  
**- Ideally the two pilots calculating OPT should copy/enter the ATIS separately.**
- The load sheet arrives and the CM1 checks it. During this check the TOW is read out and the CM2 enters it into the OPT (as does the CM1). At this point the concept of independent data cross check breaks down as the CM2 copies the TOW read out by the CM1 – and they cross check the same number against each other.  
**- Ideally the two pilots calculating OPT should copy/enter the TOW from the load sheet separately.**
- The CM2 powers up the laptop after the load sheet calculations are complete, turns to the captain and says “We calculated takeoff weight at 345.1 – what weight do you want to use in the OPT?” CM1 considers and replies – “Let’s add 500 Kg or so – make it 314.5” At this point the independent cross check philosophy breaks down as a single source of data is used to determine the takeoff weight. Did you pick up on the transposition?  
**- If you insist on using an additive to the load sheet Take Off Weight for OPT – make it an additive – use “Let’s add 500 Kg”, rather than a specific weight.**

No SOPs can proceduralise OPT usage to the point where all possibility of error is removed. There will always be a requirement on professional aviators to exercise airmanship (thank goodness) and apply common sense – such as independent cross checks – to relevant areas of the operation. It’s a simple axiom that Takeoff Performance Kills People. It’s certainly done so in the past. Be on your guard with respect to garbage in / garbage out and the OPT; as much as practicable ensure that any opportunities for error are subject to a valid crosscheck with the other pilot.

Finally the introduction of augmented crew operations to this process should improve efficiency and reduce workload **without impacting flight safety**. This requires some good management skills on the part of the Captain/Operating Crew as well as a clear understanding of the implications of task delegation and the impact on areas such as independent data sources and cross checking.

#### 8.15. ACARS OPT Check – Get what you Need, not what you Wanted

Remember that when you’re checking the ACARS OPT data that comes back from Operations – your focus should be on the validity of the data of the top half (what was entered into the Operations OPT) as well as the bottom half (the performance solution) rather than a comparison with the original request.

**Ensure the performance data you’re about to use is valid against the conditions that will exist for takeoff – rather than the conditions that existed when the original request was made.**

### 8.16. FMC Reserve Figure

The FMC Reserves figure is based on the minimum figure required at the destination airport to reach the Alternate in the event of a diversion. This includes OFP Alternate Trip, OFP Alternate Holding and OFP Final Reserves (30 minutes) Fuel.

PLANNED	TIME	FUEL
TAXI		466
TRIP FUEL	12.37	105316
CONT	00.32	3500
DEST WX/TFC	00.00	0
ALTN LAS/KLAS	00.33	6483
ALTN WX/TFC	00.00	0
FINAL RSV	00.30	3037
EDTO ADDNL		0
ADDNL		0
FUEL RQD		118802

= 9.6

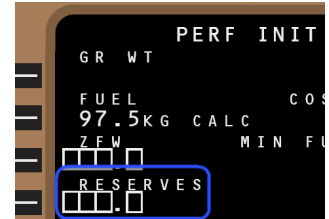

The purpose of this value in the FMC is twofold:

- The FMC scratchpad message “INSUFFICIENT FUEL” is generated when the predicted fuel on board at Route Destination is equal to or less than the RESERVES value.
- The HOLD AVAIL time calculation on the FMC Hold Page is based on arriving at Destination with at least RESERVES intact.

It should be noted that while the SOP is to insert the minimum figure into the FMC RESERVES field during pre-flight, re-considering this value during the pre-descent setup is often worthwhile. Typically most pilots prefer for the FMC to advise them slightly (1 ton or so?) prior to that point at which the flight is unable to continue to destination with OFP alternate diversion fuel intact, rather than just after an unintended commitment to destination.

In the event of a diversion from planned Destination, this figure will need to be altered. While typically the OFP 30 minute reserve fuel figure is used, entering a value of 4.2 tons should warn the crew in advance of an impending requirement to run the FUEL LOW Checklist.

### 8.17. ILS Tuning for Departure

During LVOPS, crew are advised to tune the runway ILS to provide a positive confirmation of the correct runway, and to potentially provide some lateral guidance on the runway for the takeoff.

It should be noted that localizer guidance is not certified for takeoff, nor is it a requirement for an LVOPS departure. It’s also worthy to note that the Localizer becomes more sensitive as the aircraft proceeds down the runway.

If there is no ILS for the runway of departure, it is possible to tune the reciprocal ILS for the opposite direction. In this situation the normal course QDM should be entered (as depicted on the approach chart) – the ILS received will still provide correct sense command indications on the PFD/ND. Specifically – if departing off RW16, the RW34 ILS can be tuned with a course of 340 – this will provide correct Left/Right guidance.

### 8.18. Application of CDL Performance Limits

The aircraft CDL (contained in the DDG) allows dispatch with airframe/aerodynamic defects and in some cases includes performance penalties that affect one or more phases of flight.

- Take off
- Enroute Climb
- Approach / Landing Climb
- Landing
- Specific decrements against certified Taxi/Takeoff/Landing/Zero Fuel/Max Quick Turnaround limit weights.

#### OPT Takeoff/Landing Performance Penalties

OPT will account for CDL performance penalties in the Takeoff, Approach/Landing Climb, Landing and Landing Field Length cases if the appropriate CDL defect has been selected in the software (see SOP Opt Guide, D5)

Most of the CDL defects that come with takeoff/landing performance limits affect only the **performance limit**. As such typically a CDL defect may have no impact on the resulting takeoff weight of the aircraft. Check the OPT.

That said there are CDL items that must be applied to the **Certified** weight limits, irrespective of any performance penalties (see CDL 57-31-03). OPT observes both the performance and/or certified limit penalties in the performance calculations.

Additionally the CDL introduction should be consulted for dispatch with multiple CDL defects, and provides detail on:

- The cumulative (or not) nature of multiple defects.
- Limitations to apply to multiple defects with “negligible” performance penalties.

Enroute performance penalties may need to be applied to the OFP PDA (Fuel/Drag) penalties when dispatching with a CDL defect. The CDL introduction provides detail on this, and Dispatch should be consulted. See **12.22 Enroute CDL Performance Penalties** for the practical application of checking enroute performance penalties in flight.



8.19. Re-Clearance Flight Plans & Final ZFW

Re-clearance flights plans are utilised when the need to maximise payload against a limiting takeoff weight exists – whether a performance or certified limit. The increase in payload comes at the expense of contingency fuel and the Company accepts the statistical increase in the likelihood of a diversion as the result of dispatching the flight with minimal fuel.

The essential concept is that the flight is planned to a fixed point short of the destination, and from that point a re-clearance OFP is provided to an en-route airport that requires less fuel overall than continuing to destination. In this way the flight can be dispatched to destination legally with less than standard contingency fuel - down to a minimum of 1000 Kg.

Note the Departure -> Re-Clearance WayPoint -> Alternate has it's own contingency fuel requirements defined in the A1.

It's worth noting that dispatch using re-clearance contingency fuel in combination with the fuel-closest alternate can result in low estimated (and actual!) fuel remaining at destination, which comes with its own implications for in-flight arrival planning.

V AUSTRALIA EDTO 180 FLIGHT PLAN			
FLT	NBR	DATE	ORG /DST
VAU	12	22NOV10	KLAX/YMML
PLANNED	TIME	FUEL	CORR
TAXI		833	.....
TRIP FUEL	14.33	124424	.....
CONT	00.09	1000	.....
DEST WX/TFC	00.00	0	.....
ALTN AVV/YMAV	00.24	4597	.....

ENROUTE RECLEARANCE ALTERNATE NAVIGATION LOG											
DIVERSION	DIST	TIME	AVG W/C								
YBBN	405	0055	P04								
ETI - RP	MARLN	1335	ETA . . . .	RETA . . . .							
POSN	ROUTE	MRA	FL	WIND	MTR	TAS	DIS	TIME	ETA	ATA	REMF
FIR	LATITUDE		LONGITUDE		TTR	GS	RMD	ACTM	RTA		MINR
	POSN		FULLNAME								
MARLN	DIVERT . . . . 9.0										
30S53	DCT		4/014	358	485	246	30				5.5
	S30	02.1	E153	00.0	011						
TOD	DCT	66	360	24/005	354						5.1
					006	490	130	0033			

V AUSTRALIA NAVIGATION LOG											
POSN	ROUTE	MORA	FL	WIND	MTR	TAS	DIS	TIME	ETA	ATA	REMF
FIR	LATITUDE		LONGITUDE		TTR	GS	RMD	ACTM	RTA		MINR
	POSN		FULLNAME								
MARLN	N774	35	360	13/021	263	485	25	3			12.8
YMML	S34	02.1	E153								

The re-clearance airport is not planned with (fuel for) an alternate unless the forecast weather is below the alternate planning minima (not landing minima) as defined in the A1.

In flight the crew decide prior to the re-clearance point as to whether they will be able to continue on to destination or will be required to divert to the re-clearance airport. Remember that after departure, contingency fuel is not required; only the MINR value must be achieved at the re-clearance waypoint to continue on to destination – and even that figure can be re-calculated in flight to maximise the potential of continuing to destination.

Pre-Flight : Restoring Contingency

Be aware that in this situation the OFP should be constructed – and final fuel calculated by the crew – to increase the contingency up to the standard planning figure of 3500 Kg as much as practicable.

- If the OFP is planned with 1000 Kg contingency but below the relevant performance limit (M.TOW? M.LDW?), crew should consider increasing final fuel towards the relevant weight limit to recover some contingency fuel.
- If the final ZFW drops below the planned figure – final fuel should be increased to recover as much of the 3500 Kg contingency fuel as practical.

Re-clearance dispatch comes with an inherent statistical increase in the likelihood of a diversion. When sufficient fuel exists at the re-clearance point to continue on to destination crew are then placed in the circumstances of arriving into destination with very little fuel in excess of that required to divert to alternate – commitment to destination is very likely in this scenario.

**8.20. Noise Abatement - FMC TAKEOFF REF P2/2**

The three values of Engine Out Acceleration Height (EO ACCEL HT), All Engine Acceleration Height (ACCEL HT) and All Engine Thrust Reduction Height (THR REDUCTION) on the FMC TAKEOFF REF page 2/2 are referenced to the departure runway elevation and are derived from a combination of airline policy, noise abatement and engine out takeoff performance requirements.

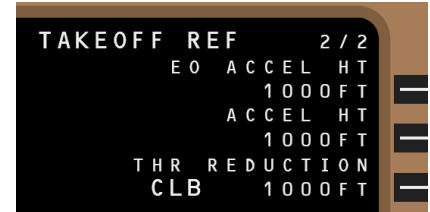

It should be noted that the small font representation of these values in the FMC indicate the Airline Policy defined defaults. If these values are correct there is no need to “harden” them up by manually entering large font values.

**Airline Policy**

V Australia standard profile in the absence of noise abatement is 1000/1000/1000. These values need to be verified by the crew during pre-flight and adjusted for any noise abatement procedures (NAP) in force, or non standard engine out acceleration height.

V Australia specifies a minimum value of 1000 ft AAL for All Engine/Engine Out Acceleration and Thrust Reduction – irrespective of any noise abatement requirement.

**Noise Abatement Profiles – NADP1 / NADP2 (and ICAO A & B)**

There are two ICAO Noise Abatement Procedures (NAP) documented in the A1 and LIDO – NADP1 and NADP2.

An airport/regulatory agency may specify the use of one of these two procedures, in which case crew should enter FMC settings to comply with the requirement. When

the airport/regulatory agency specifies a Noise Abatement requirement without a specific profile – the crew have the ability to choose either NADP1 or NADP2. In some cases Flight Operations may recommend one particular NAP profile for a specific airport/runway (eg: YSSY RW34L) – this will be documented in the C1.

	Standard	NADP1	NADP2	ICAO A	ICAO B
EO ACCEL <sup>1</sup>	1000 (OPT value if higher)				
ACCEL <sup>1</sup>	1000	3000	1000	3000	1000
THR REDUCTION <sup>1</sup>	1000	1000	Flap 1/5 <sup>2</sup>	1500	Flap 1/5 <sup>2</sup>
Then UP Speed to	-	-	3000 <sup>3</sup>	-	3000 <sup>3</sup>

<sup>1</sup> Increase to at least EO ACCEL as required by OPT.

<sup>3</sup> Where appropriate, maintain UP speed to 3000 ft AAL.

<sup>1</sup> EO ACCEL (OPT) is a minimum height for all EO ACCEL / ACCEL / THR REDUCTION entries, irrespective of NAP.

<sup>2</sup> NADP2/ICAO B requires thrust reduction with the first stage of flap retraction during the acceleration segment. This is enabled through the FMC CDU TAKEOFF REF Page 2/2 by entering the flap selection that is one less than the takeoff flap selection. Note that a subsequent change of takeoff flap setting may require an update of the entered CDU THR Reduction Flap setting.

Takeoff Flap	CDU Thr Reduction
5°	1
15°	5
20°	5

<sup>3</sup> NAP procedures that specify acceleration below 3000 ft AAL usually require VzF (Flaps Up Speed) to 3000 ft AAL – which may also require either MCP Speed Intervention or a FMC VNAV Climb Page speed/altitude restriction to comply at lighter operating weights.

Note that the NADP1 specification is minimum/maximum altitudes and as such the values are often interpreted differently by various airlines/regulatory authorities. The table above reflects V Australia’s NADP1 requirement.

The B777 FMC can schedule a second segment climb speed (all engine) up to V2+25 knots. This is considered acceptable for the purposes of noise abatement. (A1 8.3.1.8 Noise Abatement Procedure)

Finally some airfields give specific a NAP, typically based on out of date procedures such as ICAO-A or ICAO-B. Accordingly crew should make FMC selections to follow these profiles. Remember that any specified altitude requirements will have to be converted to heights above runway prior to entry into the FMC TKOFF REF P2/2.

**Engine Out Acceleration Height**

V Australia standard engine out acceleration height is 1000 ft AAL. OPT may specify a height in excess of this, in which case all three height values on FMC TAKEOFF REF P2/2 should reflect this height increase.

For example, if Noise Abatement is not required and the OPT ACCEL HT is 1130 ft, FMC EO ACCEL HT, ACCEL HT and THR REDUCTION should all be set to 1130



### 8.21. FMC vs CFP Lat/Lon Waypoints and Positions

The FMC Pre-flight requires both crew to **independently** verify the uplinked/entered FMC route against the OFP.

#### Lat/Lon Waypoint Line Selection

When a route includes lat/lon waypoints, this verification must include line selection of these waypoints into the FMC scratchpad. The FMC displays all lat/lon waypoints using an abbreviated **N26E179** format whether crossing exact meridians/parallels or not. Scratchpad verification is the only way of ensuring accurate lat/lon FMC values.

The PM/PF must **line select** each Lat/Lon waypoint into the FMC scratchpad to verify accuracy against the OFP.

#### Route Checking

Route checking consists of a basic Airway/Waypoint cross check between the OFP and the FMC. If uplinked, both pilots independently check the result. If manually entered – the second pilot checks the first pilot’s work. There are two recommended OFP pages for route checking.

- OFP Filed ATS Plan page; or
- OFP Navigation Log pages.

**OFP ATS Plan** : The OFP ATS page summarises the route into airways/airway crossing waypoints and is normally the most efficient for cross checking the OFP against the FMC RTE pages. However lat/lon waypoints may not be of sufficient detail on the ATS page for accurate checking and no track/distance information is available.

**OFP Navigation Log** : The Navigation Log page **provides** a full representation of the flight plan including detailed lat/lon waypoint and true/magnetic tracks and distance. However the Nav Log can contain extraneous waypoints such as FIR crossing boundaries that are not uplinked to the FMC, or in the ATS plan. Additionally the Nav Log can be cumbersome when checking airway/airway intersection waypoints against the FMC RTE pages.

It should be noted that the OFP abbreviates latitude/longitude waypoints into a format that is not acceptable for cross checking or manual entry into the FMC (eg **27S70**) in the route description on the main OFP page.

### 8.22. FMC Track/Distance Checking – Oceanic, Lat-Lon, Off Airway Waypoints

The route of flight must be checked by both pilots independently during pre-flight. In addition to this, any route segments involving latitude/longitude waypoints also require a track/distance check of OFP against FMC LEGS page data. This check should also be done on segments using off airway waypoint to waypoint tracking in Oceanic Space, even if no lat/lon waypoints are involved.

Tolerance should be within  $\pm 2^\circ$  Track and  $\pm 2$  nm between the FMC LEGS page and the OFP Navigation Log pages.

There is no requirement for an independent/double cross check on tracks/distances. This check is in fact best done by the two operating crew working together FMC against OFP.

**FILED ATS PLAN**

```
-N0497F310 DCT SY G595 ALLOC DCT GORDO DCT 31S160E 2955S16300E
2746S16817E/N0499F330 27S170E 2500S17304E 20S180W
1655S17616W DCT IKENA DCT 05S164W/N0495F350 00N160W 05N156W DCT
WINTY B581 CAMOS DCT 20N140W/N0482F370 27N130W DCT WEDES B581
FICKY C1177 SXC V208 VTU V25 LAX DCT
```

**V AUSTRALIA EDTO 180 FLIGHT PLAN**

FLT NBR	DATE	ORG /DST	ACFT/REG	PLAN ID	GRIB
VAU 1	18MAR09	YSSY/KLAX	B77W/VHVPD	31160106	1800

DM ROUTE IDENTIFIER - SYDLAX8HQ

```
YSSY DCT SY G595 ALLOC GORDO 31S60 27S70 20W80 IKENA 05W64 00N60
05N56 WINTY B581 CAMOS 20N40 27N30 WEDES B581 FICKY C1177 SXC V208
VTU V25 LAX DCT KLAX
```

**V AUSTRALIA NAVIGATION LOG**

POSN	ROUTE	MORA	FL	WIND	MTR	TAS	DIS	TIME	ETA	ATA	REMF
FIR	LATITUDE	LONGITUDE			TTR	GS	RMD	ACTM	RTA		MINR
27S70	DCT	16	330	25/078	063	499	102				
	S27	00.0	E170	00.0	064	576	5554				
NFFF0	DCT	10	330	24/071	043	500	204				
NFFF	S25	00.0	E173	04.1	054	569	5350				
20W80	DCT	31	330	23/046	053	500	487				
	S20	00.0	W180	00.0	052	546	4863				

**FMC Scratchpad:**

```
ACT RTE 1 L
063°
S27E170
043°
S25E173
053°
S05W180
<RTE 2 LEV: S
S2500.0E17304.1
```

### 8.23. FMC Initialisation with ACARS Uplink

Boeing do not document an FMC Initialisation procedure via Datalink. As such the procedure published here is advisory only.

V Australia currently uplinks the **Route, Flight Number, Route Winds, Descent Forecast Winds** and **ACARS COM Company Flight Information** page. PERF INIT and TAKEOFF REF data is not uplinked and needs to be manually entered by the crew from the OFP.

The overview of this process is to uplink, load and where necessary activate and/or execute the Route, Flight Number, Route Winds and Descent Forecast Winds.

**Delays in loading, activating and executing the various components can result in buffer overruns, particularly in respect of multiple wind uplinks. Each time the FMC has completed a stage - move on with the uplink process.**

Once uplinking is complete, the crew member should complete the conventional Boeing FCOM documented FMC initialisation procedure. During this follow up procedure, entries should be verified as uploaded correctly (against the OFP) or entered where incorrect or missing.

Once the FMC pre-flight initialisation is complete, the ACARS COM Company Flight Information page should be completed to enable automatic movement messages (Out, Off, On, In). These automatic messages are in addition to the required manual **Departure** and **Arrival** reports.

The process of uplinking the initialisation components can take several minutes with interruptions as the Route and Winds are uplinked; loaded; activated & executed (where necessary). Note that wind uplink is part of the Route Request – a subsequent Wind Request should not be necessary.

Crew may commence the uplink procedure; then commence other activities while waiting for the uplinks & loads to complete. The **FMC COMM** page should be checked for **Data Link Ready** in the event that there is doubt about a connection. Remember the ADIRU must be aligned for SATCOM link; VHF-C should be in **DATALINK** to enable VHF Datalink and minimise Satcom costs.

#### FMC Datalink Initialisation Procedure.

**INIT REF** key ..... Push

**INDEX** line select key..... Push

**IDENT** line select key..... Push

**IDENT** Page ..... Verify

**Verify** MODEL ..... **777-300.2**

Engine Rating ..... **GE90-115BL**

Active Nav Data Base ..... **Check Date**

Drag/FF correction factors ..... **Against OFP**

**POS INIT** line select key..... Push

**Time**..... **Verify Correct**

**Inertial Position** ..... **Enter**

*Enter inertial position using the most accurate lat/lon available (GPS).*

**FMC COMM** key ..... Push

**DATALINK READY** ..... **Verify**

**Note:** *VHF-C should be in DATA to minimise ACARS costs. IRS Alignment is required for ACARS via SATCOM to function.*

**RTE 1** line select key ..... Push

**ROUTE REQUEST** line select key ..... Push

**Note:** *This initiates a data link request for a Route, Flight Number, Enroute/Descent Winds and ACARS Initialisation page.*

**LOAD** line select key (When <LOAD prompt appears) ..... Push

**ACTIVATE** line select key (When <ACTIVATE> prompt appears).. Push

**EXEC** key (When *Execute Light* illuminates) ..... Push

**FMC COMM** key ..... Push

**Verify All Uplinks are loaded** ..... Enter

*(Small Font Uplink indicates pending data)*

**LOAD**      **Winds :** **FMC COMM** : <WIND, LOAD & **EXEC**

**Desc Winds :** **FMC COMM** : <DES FORECAST, LOAD

**Standard FMC Initialisation** ..... **Commence & Complete**

**Note:** *Crew should determine the NAP values from LIDO/C1 and enter.*

**PROG** line select key ..... Push

**PROG Distance To Go to Dest**..... **Check Against OFP**

*Allow for discrepancies in SID, STAR and other route variations.*

**RTE** key..... Push

**ROUTE COPY** line select key..... Push

**Note:** *V Australia SOPs prohibit the entry of the following items during Pre-Flight FMC Initialisation:*

*ZFW, Engine Out Acceleration Height, CoG, Selected Thrust & De-Rate, Flap Selection, Takeoff Speeds.*

**ACARS Initialisation**

*Once the FMC Initialisation is complete, the **ACARS COM Company Flight Information** page can be completed.*

**Date** (Use UTC Departure Date) ..... **Enter from OFP**

**Crew Staff Numbers** (Verify Positions)..... **Check**

**Note:** *Enter Departure, Destination, Flight Time, Alternate, etc as required if not uplinked correctly.*

*Staff Numbers are **Crew Positions** (ie: CM1, CM2, CM3, CM4 not Capt/FO as labelled in the COM page)*

8.24. Use of OFP RAMP and LNDG fuel correction figures

The OFP RAMP/LNDG figures and their use are the cause of some considerable confusion amongst the crew. I'll attempt here to explain clearly and simply how these figures are used specifically during the calculation of **Ramp Fuel** and **Trip Fuel** (wish me luck).

The first use of these figures will be once the Final Zero Fuel weight is provided by Load Control (see 8.26 Final ZFW – What do we do with that?).

**RAMP FUEL** : Based on the ZFW of the aircraft, the crew are required to determine the RAMP fuel figure – final refuelling figure for the flight.

- First a calculation of the adjusted minimum fuel figure is required. The difference (ACTUAL – PLANNED) ZFW is multiplied (in tons) by the LNDG fuel correction figure – the result is the change in fuel required to carry the Final ZFW to the destination.

$$\text{PLANNED RAMP FUEL} - (\text{ACT ZFW} - \text{PLN ZFW}) \times \text{Corr/LNDG}$$

$$118,802 + (211.4 - 213.124) \times 434 = 118,802 - 748 = 118.1 \text{ Tons}$$

- Next the crew consider their requirement for Extra Fuel. The PF/CM1 needs to determine whether any Extra Fuel is required at the destination.
- **Extra Fuel Enroute** : Just the additional fuel is added, in the understanding as the flight progresses, less and less of this fuel will be available as the heavier aircraft burns through some of the extra fuel.
- **Extra Fuel at Destination/Alternate** : If the Extra Fuel is required at Destination, additional fuel to burn carrying the required Destination Extra Fuel will be required, using the Corr/LNDG. As an example : 2 tons required at Dest.  
Fuel = Extra Fuel + (Extra Fuel x Corr/Lndg)  
Fuel = 2.0 + (2.0 x 434) = 2.9 Tons

**TRIP FUEL** : Trip Fuel is calculated once the TKOF WT calculation is updated for changes in ZFW and RAMP FUEL. This is a far simpler calculation – Trip Fuel is adjusted for the change in Takeoff Weight, using the Corr/LNDG figure only – you are only adjusting the TRIP fuel, not allowing extra fuel to carry the adjustment.

$$\text{PLANNED TRIP FUEL} + (\text{ACTUAL} - \text{PLANNED TKOF WT}) \times \text{Corr/LNDG}$$

$$105,316 + (329.0 - 331.460) \times 434 = 105316 - 1067\text{kg} = 104.3 \text{ Tons}$$

This calculation does not attempt to take into account the previous ruminations of the crew on ZFW adjustment/Extra Fuel. It's a simple adjustment of the planned trip fuel based on the change in Takeoff Weight the aircraft will carry to the Destination.

It's worth noting that this system was never intended for large corrects (ZFW change in excess of 3 tons) – Crew could consider a new OFP, or tempering the corrections conservatively.

A1: 8.1.10 (8-134) CORR/1000 RAMP & LNDG

These figures are provided to allow the TRIP FUEL to be adjusted for changes in Take-off weight, whatever the reason for that change.

The CORR LNDG figure should be used whenever the TOTAL FUEL figure is adjusted as it contains a fuel allowance required to carry that extra fuel. However, if the TRIP FUEL is adjusted by using fuel that is already onboard, as ADDNL, EXTRA or CONT, the CORR RAMP figure should be used as the allowance for carrying this fuel is already included as part of the TRIP FUEL.

WEIGHTS	PLANNED	F. ZFW
ZERO FUEL WT	213124	... 211.4
RAMP FUEL	118802	... 118.1
	CORR/1000 RAMP	293
	CORR/1000 LNDG	434

TKOF WT	331460	... 329.0
TRIP FUEL	105316	... 104.3
	CORR/1000 RAMP	293
	CORR/1000 LNDG	434

8.25. Uplinked Winds

The FMC LEGS RTE DATA pages can store winds at up to four levels for the flight. When the flight is planned at more than 4 enroute levels (such as F280, F300, F320, F340, F360) then someone is going to lose out. Typically in this situation the FMC ignores the first level, instead choosing to uplink forecast winds for F300 through F360, leaving F280 with no winds at all.

There's a kind of a logic to this selection. If the winds are not uplinked for the last planned level, this typically has a significantly detrimental effect on the fuel/time prediction. Usually by leaving out the initial level, the estimate for time/fuel at destination is still pretty accurate, even at pre-flight.

Unfortunately this ignores the shorter term tactical needs of the flight. During departure climb, the FMC's calculations around the suitability of F280 can be radically affected by the lack of forecast wind opposed to the wind uplinked at F300. Either the FMC will recommend bypassing F280 for F300 (where there is a tailwind) or the FMC will recommend levelling at F280 and may not recommend any climb to F300 for a very, very long time (to avoid the headwind at F300).

The best tactical solution is probably to delete the F360 level winds and insert F280 into a LEGS RTE DATA WINDS page, then request updated winds. With the F280 winds the FMC will be better able to recommend for/against level changes in the first few hours of flight. Once you've reached F300, you can re-request winds for F300 through F360 for the rest of the flight.

8.26. Final ZFW – What do we do with that?

When the final ZFW is received, a cross check process commences that involves the CM1, CM2 and two OFP Dispatch Release Message pages. This page facilitates a detailed cross check of structural and performance limiting weights against the proposed flight.

- 35	✓ Final ZFW received:	Update OPT calculations based on Final ZFW if necessary.
	Review OPT Calculation as appropriate.	
	✓ Independently the operating crew will: Calculate a new Minimum Fuel Figure. CM1 and CM2 to review Flight Data and decide if any Extra Fuel is required – Decide a Ramp Fuel Figure.	Calculate a new Minimum Fuel Figure.
	Independently Calculate Flight Weights and Fuel Figures from the Final Zero Fuel Weight and Ramp Fuel:	
	<ul style="list-style-type: none"> <li>• Takeoff Weight* (ZFW + Ramp Fuel – Taxi)</li> <li>• Revised Trip Fuel (Use OFP RAMP/LNDG corrections)</li> <li>• Landing Weight* (Takeoff Weight less Trip Fuel)</li> <li>• Arrival Fuel (Landing Weight less Final ZFW)</li> <li>• Compare Arrival Fuel with Min Diversion Fuel.</li> </ul>	<ul style="list-style-type: none"> <li>• Takeoff Weight* (ZFW + Ramp Fuel – Taxi)</li> <li>• Revised Trip Fuel (Use OFP RAMP/LNDG corrections)</li> <li>• Landing Weight* (Takeoff Weight less Trip Fuel)</li> <li>• Arrival Fuel (Landing Weight less Final ZFW)</li> <li>• Compare Arrival Fuel with Min Diversion Fuel.</li> </ul>
(*) Both Crew should compare calculation results against each other and Certified/Performance limiting weights.		
Provide Engineer/Refueler with the Ramp Fuel figure.	Give Ramp Fuel, Trip Fuel and Taxi Fuel to Load Control.	

It is suggested the CM2 complete the Master OFP; and the CM1 work in parallel on the Station Copy OFP Dispatch Release page. While the crew should work in concert, each calculation should be performed individually to ensure a valid cross check of the results.

Load control should provide the Final ZFW by ETD -0:35. They will subsequently require crew calculated Final/Ramp Fuel, Trip Fuel and Taxi Fuel. The process that follows ensures the accurate calculation of these values while protecting Structural and Performance limitations relevant to the flight. Note in the following example the Dispatch Release page is slightly altered to highlight the proper use of the columns of figures for calculation cross check.

a) **ZERO FUEL WT** : Enter the final ZFW from Load Control beside the OFP planned ZERO FUEL WT. Zero Fuel Weight should be checked against the structural limit. **At this point it's worth stopping to confer with CM2 and determine RAMP, TAXI and TRIP fuels. Then proceed with the rest of the calculations.**

WEIGHTS	PLANNED	F. ZFW	L/SHEET	STRUCTURAL LIMITS
ZERO FUEL WT	213124	(a) . . 211.4	.....	MAX ZFW 237682
RAMP FUEL	118802	(b) . . 118.1	.....	MAX FUEL 145541
TAXI WT	331926	(c) . . 329.5	.....	MAX TW 352441
TAXI FUEL	466	(d) . . . 0.5	.....	
TKOF WT	331460	(e) . . 329.0	.....	PERF LIM: <i>Rw24L: 335.5</i> MAX TOW 351534 DDG/R
TRIP FUEL	105316	(f) . . 104.3	.....	
LDW	226144	(g) . . 224.7	.....	MAX LDW 251290 DDG/R
FUEL OVER DEST	13020	(h) . . . 13.3	.....	

b) **RAMP FUEL** : The RAMP FUEL calculation is detailed elsewhere (8.24 Use of OFP RAMP and LNDG fuel correction figures) and is driven by the need to alter the fuel load for any change between Planned and Final ZFW; and the any requirement to carry extra fuel. Check RAMP FUEL against the volumetric limit (beware that the limit availability will be dependent on SG).

- c) **TAXI WT** : Add the ZERO FUEL WT and RAMP FUEL together to calculate a TAXI WT.
- d) **TAXI FUEL** : Crew can alter the taxi fuel based on parking position, likely delays, etc. 30 kg/min is an approximation.
- e) **TKOF WT** : Takeoff weight is calculated by subtracting TAXI FUEL from TAXI WT. This weight should be checked against both structural and any previously calculated OPT performance limited takeoff weight (PERF LIM:)
- f) **TRIP FUEL** : Calculate based using (ACTUAL TKOF WT – PLANNED TKOF WT) x LNDG Corr. Note that this ignores any previous calculation performed to calculate RAMP FUEL. Essentially the change in Trip Fuel is driven by the change in Takeoff Weight between Planned and Actual – a weight change that will be carried to Destination.
- g) **LDW** : Landing Weight is calculated by subtracting the TRIP FUEL from the TKOF WT. This weight should be checked against the annotated structural limit weight.
- h) **FUEL OVER DEST** : Fuel remaining over destination is the result of LDW less ZERO FUEL WT. This figure can be checked later on against the FMC estimated fuel at destination as part of the NP's : Final FMC Performance Entry.

Apart from a general gross error check of the procedures (such as, ZFW goes down, Final Fuel goes down → all other figures should go down as well) - the important aspects of this data cross check procedure are:

- Individual calculations by two different crew members to catch calculation errors.
- Cross check of Structural and Performance Limitations during the calculation procedure.

Upon completion of this procedure, CM2 will advise Load Control of the Ramp Fuel (Tons); Trip Fuel (Tons) and Taxi Fuel (Kg).



**8.27. Aircraft DOW & DOI**

The A1 requires the Captain to verify the DOW and DOI on the load sheet (amongst other things) as part of load sheet acceptance. This is done through the FODS (Fleet Operational Data Summary) found in the back of the Tech Log, corrected for any unusual crew complement.

The FODS is issued periodically for the aircraft due either re-weighting or changes to the content of the sheet (such as the introduction of new pantry codes for additional routes).

The DOW/DOI for the various aircraft/route combinations include Basic Aircraft, Potable Water, Crew Complement (with or without crew checked baggage) and relevant Pantry Code.

Adjustments are typically only required for non-standard Crew Complement. A significant difference between the Load sheet and Crew calculated DOW/DOI should be explored and if appropriate, reported in a Flight Crew Report. When investigating differences, remember to check the ALDS version with Load Control ...



**B777-300ER FLEET - OPERATIONAL DATA SUMMARY**

**FODS**

B777-300ER Operational Fleet Size: 4 Aircraft				Issue No.14 - 10 MAR 2010												
SEATING 33J, 40W, 288Y		MZFW 237682		MTW 352441		MT 351										
AIRCRAFT SPECIFICATIONS B777-300ER			ALDS		BASIC EMPTY WEIGHT		DRY OPERATING WEIGHT									
A/C	VH	AIRCRAFT SN	DOOR (SMALL/LARGE)	AFT CARGO DOOR (SMALL/LARGE)	AIRCRAFT LOAD DATA SHEET (ALDS) ISSUE NUMBER & DATE		BASIC EMPTY WEIGHT	BEW INDEX	LAX (CREW 4/13)		JNB (CREW 4/13)					
									DOW	INDEX	DOW	INDEX				
VOZ	37938		LARGE (ER)		8	25/02/2010	164582	39.6	170729	43.3	171182	43.9	171480	42.9	171506	42.9
VPD	37938		SMALL (FP)		8	25/02/2010	164107	38.9	170254	42.6	170707	43.2	171000	42.2	171031	42.2
VPE	37939		SMALL (FP)		6	25/02/2010	163764	38.8	169911	42.5	170364	43.1	170662	42.1	170688	42.1
VPF	37940		SMALL (FP)		5	25/02/2010	163810	38.1	169957	41.8	170410	42.4	170708	41.4	170734	41.4

GROUP 3: ADJUSTMENTS		
ITEM	WEIGHT	IU
OBSERVER	95	-0.40
CABIN CREW - DOOR 1	85	-0.30
CABIN CREW - DOOR 2 TO 4	85	0.00
CABIN CREW - DOOR 5	85	0.30
CREW BAGGAGE	20	0.05
J CLASS ADDITIONAL LUGGAGE	7	-0.02
POTABLE WATER + FLT LIBRARY	1369.2	4.08

GROUP 1: STANDARD CREW CONFIGURATIONS			
FM CODE	ITEM	WEIGHT	IU
	CREW 4/13 + CREW BAGGAGE	1825	-0.6
	CREW 2/11 + CREW BAGGAGE	1385	-0.1
	CREW 2/11	1125	-0.8
	TRAINING : CREW 2	190	-0.8

GROUP 2: CATERING			
FM CODE	ITEM	WEIGHT	IU
AU-LAX	PANTRY AU-LAX-AU	3704	-0.1
AU-HKT	PANTRY AU-HKT-AU	3846	0.3
AU-NAN	PANTRY AU-NAN-AU	3653	-0.3
AU-JNB	PANTRY AU-JNB-AU	3730	-0.1

**8.28. Load Sheet Arrives – OFP Dispatch Message page**

In a similar fashion to the procedure commenced after the Final ZFW arrives (see 8.26 Final ZFW – What do we do with that?) the arrival of the load sheet commences a brief crosscheck on the OFP Dispatch Release Message page.

A full re-run of the column of calculations is not necessary unless an error in the load sheet is revealed. While the ZFW may have changed, as long as the ZFW / TKOF WT / LDW meet a gross error check and are within the structural and performance limitations, there is no need to re-run all the cross check calculations.

WEIGHTS	PLANNED	F. ZFW	L/SHEET	STRUCTURAL LIMITS
ZERO FUEL WT	213124	... 211.4	(a) 211.0	MAX ZFW 237682
RAMP FUEL	118802	... 118.7		MAX FUEL 145541
TAXI WT	331926	... 329.5		MAX TW 352441
TAXI FUEL	466	... 0.5		
TKOF WT	331460	... 329.0	(b) 328.6	PERF LIM: Ru24L: 335.5 MAX TOW 351534 DDG/R
TRIP FUEL	105316	... 104.3		
LDW	226144	... 224.7	(c) 224.3	MAX LDW 251290 DDG/R
FUEL OVER DEST	13020	... 13.3		

**Note that just entering these figures from the load sheet onto the OFP Dispatch Release Message does not constitute a check of the full details of the load sheet – this must be done in parallel to the transfer of the load sheet figures to the OFP.**

- a) **ZERO FUEL WT** : Transfer the ZFW from the load sheet to the OFP. Consider any difference in ZFW between “Final” and load sheet and the impact on structural limit and fuel required.
- b) **TKOF WT** : Transfer the takeoff weight from the load sheet. Cross check structural and performance limitations.
- c) **LDW** : Transfer the landing weight from the load sheet. Cross check structural and performance limitations.

**8.29. Cleared to disconnect external power Captain?**

Engineering should not disconnect ground power without first confirming with the flight deck crew. When asked by the ground engineer for clearance to disconnect the external power – ensure that external power has been deselected on the overhead panel before clearing the ground engineer to do so. Disconnecting ground power while it’s still connected to the Bus can leave the aircraft with significant electrical system failures. Ask how we know this ...



8.30. Pre-Start Hydraulic Pressurisation

The pre-flight Hydraulic Panel pressurisation sequence should be performed exactly as documented in the FCOM. Typically it's worth noting that:

- The C1 ELEC PRIMARY is selected before the C2 ELEC PRIMARY. As well as being in the order specified by the FCOM procedure, this ensures that the C2 pumps are not pressurised needlessly during the flow.

This procedure is primarily formulated to prevent fluid transfer from the Center to Left hydraulic systems. Such a fluid transfer could potentially take place through the brake accumulator system if the hydraulic systems are pressurised out of sequence, although the mechanism of transfer is not documented by Boeing.

The post-flight procedure is again, just as documented in the FCOM and seeks to prevent both fluid transfer and unnecessary energising of the pumps.

HYDRAULIC panel.....	Set	F/O
<b>Note:</b> Pressurize the right system first to prevent fluid transfer between systems.		
Right ELECTRIC DEMAND pump selector –	AUTO	
Verify that FAULT light is extinguished.		
Center 1 and Center 2 ELECTRIC PRIMARY pump switches –	ON	
Verify that the Center 1 FAULT light is extinguished.		
The Center 2 FAULT light may stay illuminated until after engine start because of load shedding.		
Left ELECTRIC DEMAND pump selector –	AUTO	
Verify that the FAULT light is extinguished.		
Center 1 and Center 2 AIR DEMAND pump selectors –	AUTO	
Verify that the FAULT lights are extinguished.		

8.31. Dispatch with the DDG – what does “None” really mean?

When seeking guidance from the DDG for a defect – particularly *after* “Dispatch” when the DDG becomes “guidance” only – entry into the DDG typically begins with the EICAS message list. Once you’ve located your message, you’re referred to the relevant DDG entry to be given the limitations for dispatch. However some items have “None” against them. Often this is taken as “None” limits for dispatch.

**However in fact the implication is “None” Dispatch – no dispatch allowed with this defect.**

Section 1		777 Dispatch Deviations Guide		Cross Reference List
Message	Level	MEL		
FLAPERON ACTUATOR	Status	27-11-04		
FLAPS DRIVE	Caution	None		
<b>FLAPS PRIMARY FAIL</b>	Caution	<b>None</b>		

Using the illustrated failure, follow through this scenario.

The aircraft completes start/push and the engineer is dismissed. CM1 calls for “Flaps 15” and the slats start to run. Shortly thereafter,  **SLATS PRIMARY FAIL** annunciates on EICAS. The crew commence the checklist and although it contains some notes, no actual procedures are required of the crew. By the time the checklist completes, the Flaps/Slats are extended correctly, the EICAS and STATUS are clear of messages, and the aircraft seems normal. Can they go or not?

The crew refer to the DDG and find that the relevant MEL reference for this defect is **None**. The crew decide that since there are *None* limits on Dispatch, the flaps are out ok, they’ll keep going. Hopefully the crew will recognise they’ve made a mistake before advancing thrust for takeoff, generating a takeoff configuration warning sound ...



## 9. Pushback, Engine Start

### 9.1. “Can I close the Door Captain?”

This, along with “**Are you Ready for the Approach**” are two of the most loaded questions in the aircraft/simulator. The checklist of items that need to be satisfied prior to closing the doors is moderately long and un-published. It includes Load sheet, Fuel Record Form, Tech Log, Passenger Manifests, cargo doors, passenger signs, passenger address, slot times, and more. Beware of flippantly answering yes to the FM when asked this question.

### 9.2. Pushback Sequence

Because of the requirement to read both the SOP Amplification : NPs and the FCOM in parallel, the push and start sequence can be a little confusing.

- When CM1 believes the aircraft is ready for pushback, CM1 contacts the ground engineer to confirm readiness for engine start and pushback (see SOP Amplification : Standard Calls)
- Once received, CM1 asks CM2 to obtain push (as appropriate) and start clearance from ATC.
- With Start/Push clearance obtained, CM2 automatically commences the before start flow up to the EICAS Recall, which requires CM1 input. Note there is no need for a call from CM1 to initiate the Before Start CM2 flow (such as “Cleared to Pressurise”)
- Once CM1 has reviewed the EICAS and called “**Cancel EICAS**”, CM1 will set the trim (hydraulics are pressurised by this point and the Beacon is ON). **Meanwhile CM2 finishes the before start flow with the EFIS CHKL button to display the Before Start Checklist.**
- This checklist is then completed. At this point CM1 contacts the ground engineer and confirms the pushback/start instructions. Pushback commences.

This sequence is Boeing compliant and is selected to ensure the aircraft is not pressurised for any significant amount of time prior to ATC pushback clearance. Once the beacon goes on all ground traffic activity around the aircraft ceases – at busy international airports, aircraft waiting for a delayed push with the beacon on **degrades** efficient airport operations.

### 9.3. “Cleared to Pressurise?”

There is no standard call between CM1 and CM2 clearing CM2 to pressurise the hydraulics. CM1 will obtain pressurisation clearance from the ground engineer BEFORE requesting that CM2 obtain start clearance. As such, once start clearance is obtained, CM2 should launch straight into the Before Start Flow.

### 9.4. Start during push back

There is no limitation in starting either or both engines (one after the other) during pushback. There is also no technical reason for starting one engine in preference to the other. A minor consideration is perhaps starting the engine that is inside the turning pushback to minimise stress on the towbar, but this is not considered limiting.

Start during push is considered normal practice and is to be encouraged as normal operation during training. Note however that there may well be local limitations associated with parking position, or a limitation associated with a non-777 rated tow bar that may preclude engine start during push back.

### 9.5. Engine Number One or Left Engine

By convention, all internal flight deck communications refer to the engines as Left or Right. External communications, such as with the ground engineer, should use “**Number One**” (Left) or “**Number Two**” (Right) terminology.

### 9.6. Fuel Control Switch to RUN During Start

The Fuel Control Switch can be moved to RUN during the engine start as soon as the CM2 has moved the Engine START/IGNITION selector to START. There is no requirement to wait for Oil Pressure, engine rotation or oil temperature.

### 9.7. Starting engines quietly

There are two normal engine start calls. They are “**Start Left**” (Engine) and “**Oil Pressure**”. Calls during Autostart such as “Fuel On”, “Rotation”, “Light Off”, “Starter Cutout”, “Roll Back”, “Stable” and more are superfluous and not required (nor in accordance with SOP). Engines Stable after start and the subsequent CM2 flow, is assessed through the removal of the EGT Start Limit Indication on the EICAS after engine start.

### 9.8. Start Abnormalities and the Outside World

During start abnormalities, try to resist the tendency to lose the outside world. There are probably people out there who would love to hear that you have a hot/hung start and plan on blocking the taxi way and keeping the ground engineer from his coffee for at least another 2-3 minutes, perhaps more. Share and enjoy.

### 9.9. Clear to disconnect after Recall

The engineer should not be cleared to disconnect headset from the aircraft until the Recall during the after start flow has been acknowledged and cancelled (“**Cancel EICAS**”) by the CM1. The function of the EICAS Recall at this point is for the CM1 to be satisfied that after start the aircraft is fully serviceable to Dispatch for the flight.

### 9.10. Engine Anti-Ice ON after start

When required, the EAI should be selected on **after each engine start** – do not wait for the after start flow once both engines have been started. The Boeing FCOM defines icing conditions to be a combination of outside air temperature at or below 10° combined with low visibility (1600m / 1sm) and/or precipitation on the plane, ramp, taxi-ways or runway.

### 9.11. Guarding Fuel Control Switches

AUTOSTART handles almost all start abnormalities that are likely to require intervention on the 777. Traditionally the Captain would be expected to guard the Fuel Control Switches during engine start in order to prevent a Hot Start. This is not considered to be a requirement during engine start on the 777.

While there is the remote possibility of a Hot Start (combined with an Autostart system failure) during which the Captain might have to intervene – training has historically shown that the more likely result of hands on the fuel control switch during start is inappropriate intervention in a start that’s being managed quite well by Autostart.

As such Training recommends that Captains do not keep their hands on the Fuel Control Switches during start. Rest them on the Thrust Levers instead, while monitoring engine start progression.

Autostart corrects for:

- no EGT rise
- a hot start
- a hung start
- no N1 rotation
- a compressor stall
- a starter shaft failure
- insufficient starter air pressure
- a start time that exceeds the maximum starter duty cycle time

Do the ABORTED ENGINE START checklist for the following abort start condition:

- there is no oil pressure indication after the EGT increases

### 9.12. Anti-ice and the Before Taxi Checklist

When EAI has been selected on after engine start, the proper response to the Before Taxi Checklist’s “**ANTI ICE ...**” is “**AUTO ... ON ...ON**” indicating the status of all anti-ice – Wing, Engine, Engine.

10. Taxi

10.1. Takeoff Review – Read the Glass!

The Takeoff Review is strictly a glass reading exercise. The only instruments that should be referred to are the two CDU's and the ND/PFD. Do not read the V2, Selected Altitude/Heading from the MCP.

10.2. Weather Radar ON during Taxi

SOPs specify that the weather radar should go on during taxi after the cabin ready and Takeoff Review have been completed. That said, if the aircraft is taxiing such that a 20/40 mile weather radar display would give a preview of the weather on departure – WXR should be selected on for this purpose, and can be selected off if necessary once that appreciation is gained.

10.3. When to run the Before Takeoff Checklist

After taxi commences, PF will wait until the aircraft is in a clear area and the mental demand of taxi is low (straight line, wide taxi way, etc) and if an airways clearance has been received and briefed, will call for the Takeoff Review. Upon completion of the Review, PM will display the Before Takeoff Checklist. The checklist can be run when (a) Cabin Ready has been received; (b) the Takeoff Review is complete; and ideally (c) Weather Radar/Terrain selections have been made.

10.4. Thrust Usage on the Ground

The thrust produced by the 777-300 engines at idle is considerable – at most weights the breakaway thrust requirement is not much more than idle.

As such it is crucial for the Crew to maintain situational awareness of what is behind the aircraft anytime thrust is increased above idle while taxiing.

Thrust increases are often required for:

- Taxi commencement at very heavy operating weights.
- Turns or 90° or more, particularly on narrow taxi ways where turns are conducted with appropriate judgemental oversteering.
- Sloping taxiways – particularly associated with turns.

Thrust increase should generally be anticipated – that is, thrust applied just before it's required. In concert with this anticipation, the area that will be behind the aircraft when thrust is to be increased should be considered by the flight crew. Damaging ground equipment and personal is well within the capabilities of the thrust output of the 777 engine during normal taxi operations.

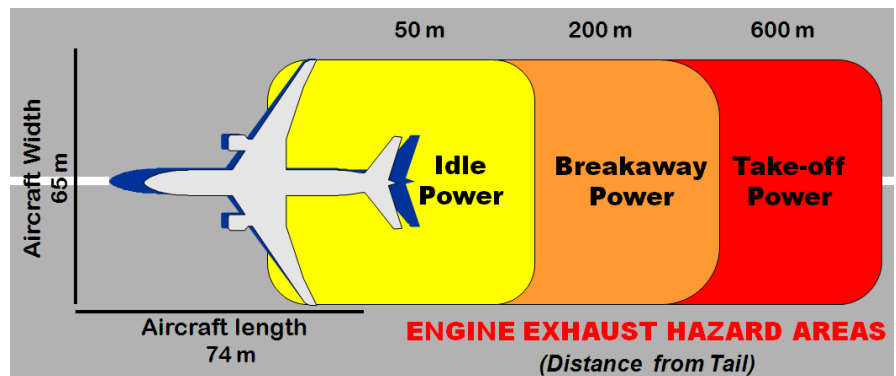

10.5. Carbon Brakes – Operating Differences

There are operating differences between the 777's Carbon Brakes and the steel brakes found on older aircraft. The primary operating difference stems from the wear nature of the material. The two significant factors affecting carbon brake wear are the physical number of applications (rather than the length or strength of application) and the temperature of the material during the application of braking. Within reason the warmer carbon brakes are during multiple braking applications, the less the brake wear.

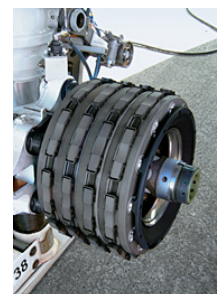

Operationally this means that brake wear is reduced by a small number of long, moderately firm brake applications instead of numerous light applications. Hence the technique of allowing speed to build up during taxi (appropriate to the taxi environment) and a single continuous brake application to reduce speed significantly before allowing taxi speed to increase again.

The use of Autobrake 1 for landing can increase carbon brake wear when the intent is a roll through on the runway. This is because the combination at Autobrake 1 and Reverse Thrust can result in the cycling of the brakes to maintain the low rate of deceleration commanded.

10.6. Returning to Stand

Whether due technical, operational or a passenger issue, returning to stand is not a manoeuvre supported directly by the SOPs. Usually the key to covering yourself for a return to stand situation is to assume you've just cleared the runway after landing and commence the appropriate flow (easiest to initiate by calling for the After Landing Checklist). Don't forget to consider communications as part of the decision/implementation of a return to stand. ATC, Cabin, Company, etc.

10.7. Taxi Technique – General Tips

The FCTM contains fairly comprehensive guidance on taxiing the aircraft in a variety of conditions. Issues such as flight deck perspective and visual cues, taxi speeds, oversteering, thrust and rudder/tiller usages are essential reading for safely, efficiently operating the B777 aircraft on the ground. The following tips directly address taxi deficiencies that have been observed during line operations.

- Turns of near 90° or more should be entered at no more than 10 knots (less if the ground surface is slippery). This significantly reduces the centrifugal effects on passengers at the rear, as well as the likelihood of the tyre scrubbing associated with turns on painted surfaces (wet or dry).
- Typically, outside engine thrust application will be required during turns of 90° or more on dry surfaces at heavy weight to keep taxi speed up near 10 knots. As with all tactical thrust usage on the ground, application should be anticipated and the area behind the aircraft verified clear of frangible items. Be particularly aware when turning through 90° with light objects such as empty ULD's on the Apron or beside Taxi-ways.
- Oversteering is a requirement on narrow taxi ways and should be regularly practiced on wider ones. The visual cues described in the FCTM work and should be practiced to increase confidence in them for the day when they are required on particularly narrow taxiways (New York, here we come).
- On particularly narrow taxi-ways, the PF may have to parallel the edge of the taxiway until the mains have come clear of the edge prior to returning to centreline.
- The Tiller must be used with a good grip and smooth inputs applied to avoid the "jerking" that can be felt down the length of the aircraft when the tiller is not used smoothly. This is particularly so when releasing the pressure on a tiller coming out of a turn.
- Since it's introduction on the 777, Main Geer Steering Takeoff Configuration Warnings during takeoff thrust application (too) shortly after turning onto the runway have been an occasional accompaniments to those new to the aircraft. Main gear steering operates when the nose wheel steering input is more than 13° and speed is less than 20 knots, which pretty well describes the parameters of every runway entry for takeoff. Ensure a few seconds are left to allow the main gear to straighten before applying takeoff thrust.

Taxi .....	2.2
Taxi General .....	2.2
Flight Deck Perspective .....	2.3
Thrust Use .....	2.4
Backing with Reverse Thrust .....	2.5
Taxi Speed and Braking .....	2.5
Antiskid Inoperative .....	2.6
Tiller/Rudder Pedal Steering .....	2.6
Turning Radius and Gear Tracking .....	2.7
Visual Cues and Techniques for Turning while Taxiing .....	2.8
Turns of 180 Degrees .....	2.8
180 Degree (Pivot) Turns in Less than 147.6 feet / 45 m .....	2.12
Taxi - Adverse Weather .....	2.14
Engine Out Taxi .....	2.15

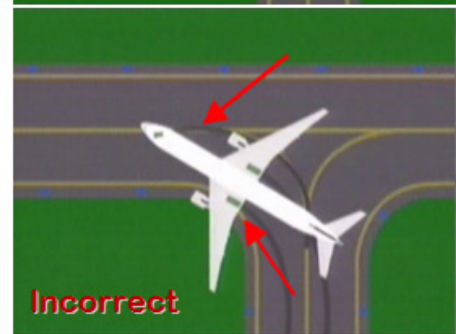
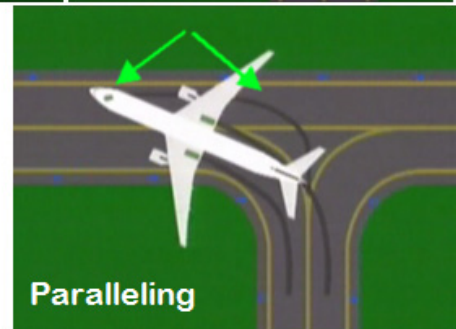
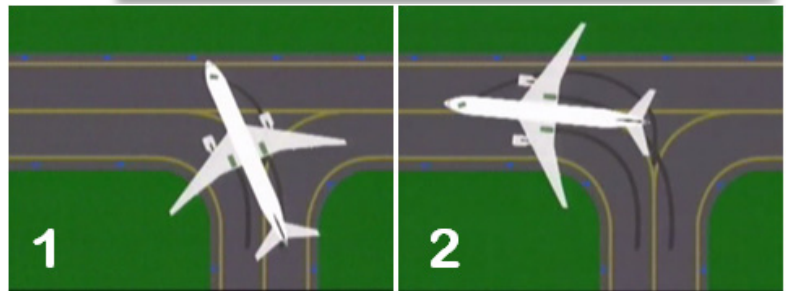

## 11. Takeoff

### 11.1. HDG/TRK Select (and HOLD) for takeoff

While Heading/Track Select will engage on the ground, and might even seem like a good idea when ATC want runway heading, or a turn straight after takeoff, the practice is discouraged for the following reasons.

- If the mode is commanding a turn, the turn will commence very shortly after takeoff – irrespective of an engine failure that may occur and any subsequent engine out procedure that may apply.
- If Hdg/Trk Select is engaged other than when the aircraft is lined up on the runway, when the aircraft gets airborne, the Hdg/Trk Select logic may command a turn in the shortest direction based on which way the aircraft was pointing on the ground when Hdg/Trk Select was engaged.

As such the use of Heading Select – and Heading Hold – prior to takeoff is not encouraged. Instead, call for a lateral mode at 400ft when prompted by the PM.

### 11.2. FMC Climb Direct Feature on the ground

The FMC climb direct feature (CDU VNAV CLB page) actions with a single button push (followed by execution) the deletion of all legs page altitude constraints between the current aircraft attitude and the MCP selected altitude, or FMC Cruise Altitude, whichever is lower.

Each individual legs page speed/altitude constraints can be deleted with a single push of the MCP Altitude Selector without a need for Confirm/Execute ... except on the ground where the MCP Altitude Selector knob push is disabled. In this situation, the FMC Climb Direct feature still works as described.

### 11.3. Main gear steering and Thrust Application

As crew become more confident with the aircraft, the occasional takeoff configuration warning is generated during thrust application on takeoff, when the main gear steering hasn't been given sufficient time to align and lock. This is generally best avoided – don't rush into TOGA when a sharp turn has been required during line up.

### 11.4. Takeoff – wait for 55%

Boeing specify thrust stabilisation at around 55% (the actually number is not important) during thrust advancement for takeoff prior to TOGA switch activation. Two common errors associated with this are (a) pressing the TOGA switch too early, thus exposing the aircraft to the risk of asymmetric thrust application at very low (below  $V_{MCG}$ ) airspeeds; and (b) pausing too long trying to accurately achieve 55% prior to TOGA, using valuable runway in the process.

Takeoff and Initial Climb



777 Flight Crew Training Manual

#### Initiating Takeoff Roll

Allowing the engines to stabilize provides uniform engine acceleration to takeoff thrust and minimizes directional control problems. This is particularly important if crosswinds exist or the runway surface is slippery. The exact initial setting is not as important as setting symmetrical thrust. If thrust is to be set manually, smoothly advance thrust levers toward takeoff thrust.

### 11.5. "Takeoff" ... Then TOGA Switch

The "Takeoff" call from the PF is a decision/statement of intent call. Essentially it formalises the age old : PF : "You Ready?" ... PM : "Yup" that pilots have been saying at each other as the aircraft straightens up on the runway and the crew commence the roll. It's the last chance for one of the pilots (typically the PM if the PF has announced intent) to halt the takeoff – whether for lack of clearance, blocked runway or some other reason.

For this reason, the "Takeoff" call should take place well before TOGA switch activation. Abandoning a takeoff roll commenced in error is a far simpler proposition if actioned prior to Autothrottle engagement. This is why the SOPs script the "Takeoff" ... "Check" sequence prior to TOGA Switch Activation.



### 11.6. Eighty knots, Check, Hold, Check

Normally this would be the correct response to an airspeed awareness call from the PM, and an FMA change called by the PF. However Take Off is an SOP scripted event. The correct calls are documented. During takeoff when PM sees 80 knots IAS, PM calls “**Eighty knots**”. PF looks down and cross checks his ASI, then looks up at the FMA, sees the Thrust mode change and calls “**Hold**”. PM does not acknowledge this last call.

### 11.7. Increasing VR for Strong Crosswind Conditions / Windshear

The Boeing FCTM advises using **TOGA Thrust and** a higher VR during strong and/or gusty crosswinds. Increased rotation speed provides increased tail clearance and stall speed margin.

#### Improved Climb

The FCTM also recommends the use of “Improved Climb”. Improved Climb is essentially the increase of V2 (and by association possibly Vr and V1 as well) to gain better second segment climb performance. OPT uses improved climb on a tactical basis as and when required to maximise takeoff performance. There is no ability for Crew to turn on Improved Climb if it’s not already in use, or increase the use of Improved Climb if it is being used.

#### Increasing VR

The concept of increasing Vr is based on the extra thrust available when the takeoff is at less than the performance limited takeoff weight **and full TOGA Thrust is used**.

To provide the data, two takeoff performance solutions are generated – one for the actual weight, one for the performance limited weight (or structural limit if less). This second solution provides the performance limited Vr, which is not to exceed the actual weight Vr plus 20 knots.

Speeds are set for the actual weight solution (not the increased Vr). Rotation is delayed until the performance limited Vr (not to exceed actual weight Vr plus 20 knots). Once airborne the takeoff is continued normally, rotating to the all engine climb attitude until the flight director gives correct guidance.

The Boeing FCTM offers specific suggestions when using this technique during gusts and crosswinds which should be reviewed as part of the Departure Briefing. By implication, the use of TOGA thrust as a response to strong crosswind conditions is a requirement of this technique.

#### Windshear

The FCOM SP for Adverse Weather recommends a similar technique when a takeoff is undertaken in potential windshear conditions. The calculations involved and settings are as above, the differences occur in the event of a windshear encounter during the takeoff.

If windshear is encountered rotation **must not be delayed** until the increased VR, but commenced at the actual weight calculation rotation speed.

To increase tail clearance during strong crosswind conditions, consider using a higher VR if takeoff performance permits. This can be done by:

- using improved climb takeoff performance methods
- increasing VR speed to the performance limited gross weight rotation speed, not to exceed actual gross weight VR + 20 knots. Set V speeds for the actual gross weight. Rotate at the adjusted (higher) rotation speed. This increased rotation speed results in an increased stall margin, and meets takeoff performance requirements.

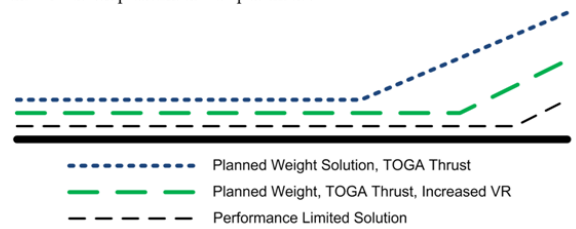

- Consider increasing Vr speed to the performance limited gross weight rotation speed, not to exceed actual gross weight Vr+20 knots. Set V speeds for the actual gross weight. Rotate at the adjusted (higher) rotation speed. This increased rotation speed results in an increased stall margin, and meets takeoff performance requirements. If windshear is encountered at or beyond the actual gross weight Vr, do not attempt to accelerate to the increased Vr, but rotate without hesitation.

11.8. Flap Retraction & Extension

During takeoff, don't delay flap retraction – call for the next stage of flap at the appropriate speed as advised in the Boeing FCTM. Delayed flap retraction at very heavy weights can hamper aircraft acceleration towards clean speed and result in unnecessary pitching moments as the next flap limit speed is approached during acceleration. Note that retraction takes place from F20/F15 → F5 → F1 → Flaps Up. Whether using Flap 20 or Flap 15 on takeoff – retract to Flap 5 once the acceleration has commenced and the speed adequate.

Takeoff Flaps	At "Display"	Flap Transition Speed	Select Flaps
20 or 15	"20" or "15"	Vref 30 + 20	5
	"5"	Vref 30 + 40	1
	"1"	Vref 30 + 60	UP
5	"5"	Vref 30 + 40	1
	"1"	Vref 30 + 60	UP

During approach, crew should ideally not extend flap to the next selection until approaching (within 20 knots) the minimum speed for the existing flap. Early flap extension results in unnecessary wear and tear on the flaps. On some Boeing types (notably the B747-400) there are Boeing and Company specific recommendations against the use of Speedbrake with any Flaps extended. The 777 FCTM recommends against significant Speedbrake extension with Flaps in excess of Flap 5 (due turbulence over the horizontal stabiliser). Other than this, Speedbrake is very much preferred over Flaps as a means of increasing drag on the aircraft when fast/high on descent/approach.

Unlike the 737, it is unusual for crew to skip standard flap settings during extension (other than F15/F25) and generally an indication of a poorly planned/managed initial approach. The "Standard" approach/Landing is Flap 1, Flap 5, Gear Down Flap 20, Flap 30.

Flap 15 on Approach

While specifically identified as a Takeoff Flap setting, the FCTM also refers to Flap 15 as suitable when manoeuvring prior to approach. Flap 15 is not recommended as a regular setting for a low drag approach – the FCTM specifically identifies the Gear Up / Flap 20 configuration for low drag during approach. The use of Flap 15 does not require pre-facing it with "Non Standard". It's just a flap setting.

Flap 25 on Approach

Flap 25 on the other hand is specifically denoted a Landing Flap Setting by the FCTM. Unlike Flap 15 – the selection of Flap 25 does not result in a "25" minimum speed indication on the airspeed tape. Typically PF calls for Flap 25 because of a fast/late approach where the aircraft is close to the Flap 30 limit speed. The lack of a minimum speed indication on the airspeed tape should be taken as an indication that Flap 25 should not be used during approach unless it's the landing flap selection.

11.9. Takeoff Rotation Rate

According to the Boeing FCTM, Takeoff Rotation should be a smooth continuous rotation of 2 to 2½ degrees per second towards 15° of pitch reference. Additionally, the attitude indicator is the primary pitch reference.

The first thing to note here is that rotation should be smooth and continuous – the aircraft has a tendency to slow it's pitch rate at about 10° of pitch (as the mains leave the ground) – rotation must continue through this point and the rotation should not be allowed to stagnate. Note also that Boeing recommends a consistent rotation technique and approximately equal control forces.

The second point worthy of note is that rotation should take place towards 15°. The actual pitch attitude the aircraft stabilises at will be the result of a complex calculation of weight, thrust, centre of gravity, etc.

When your rotation technique is correct, you will notice two things – firstly you are pointed at the same place as the flight directors once your rotation is complete (note this is not an invocation to use the flight directors during rotation); secondly your airspeed will be very close to that written at the top of the CDU VNAV CLB page – V2+25 knots.

Takeoff and Initial Climb

**BOEING**  
777 Flight Crew Training Manual

**Rotation and Liftoff - All Engines**

For optimum takeoff and initial climb performance, initiate a smooth continuous rotation at VR toward 15° of pitch attitude. The use of stabilizer trim during rotation is not recommended. After liftoff, use the attitude indicator as the primary pitch reference. The flight director, in conjunction with indicated airspeed and other flight instruments is used to maintain the proper vertical flight path.

**Note:** Do not adjust takeoff speeds or rotation rates to compensate for increased body length.

With a consistent rotation technique, where the pilot uses approximately equal control forces and similar visual cues, the resultant rotation rate differs slightly depending upon airplane body length.

Using the technique above, liftoff attitude is achieved in approximately 4 seconds. Resultant rotation rates vary from 2 to 2.5 degrees/second with rates being lowest on longer airplanes.

**Note:** The flight director pitch command is not used for rotation.

**Typical Rotation, All Engines**

The following figure shows typical rotation with all engines operating.

### 11.10. VNAV Path after Take Off?

When operating from Runway 24/25 at LAX, departing on the PERCH9 or the LAXX6 (and several other SIDS), VNAV may change from SPD to PATH after takeoff, seemingly refusing to accelerate above 1000/3000 AAL. This is often perceived as a failure of the VNAV mode and a reversion to basic modes (Flight Level change) is suggested by the PF/PM/Sim Instructor.

While it's crucial for crew to learn to detect unusual behaviour in the AFDS and react accordingly with a reversion to a more basic level of automation, it's also good value to understand the what and why of AFDS anomalies. In this instance, VNAV has reacted correctly to its programming.

While VNAV climbs are essentially a **fixed thrust/selected speed based calculation** (see below), in this case VNAV has decided the SMO160R/3000B restriction is at risk, and has engaged in VNAV PATH in order to meet that restriction. Acceleration will occur once the restriction has been met. This situation **can be** exacerbated by the excess thrust available at lower weights, and the use of 3000 ft AAL for noise abatement.

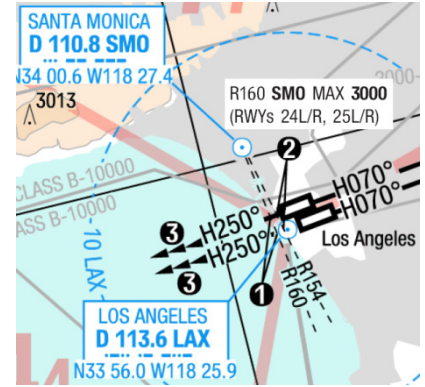

There is a fundamental difference in the design of VNAV between climbs and descent – at least between climb after takeoff to cruise altitude and descent from cruise altitude to the approach. The difference is VNAV PATH. Essentially typical VNAV Climb is **thrust/selected speed**. The auto throttle is commanded to limit thrust (CLB, CLB1, CLB2, etc) and VNAV commands the elevators to maintain an airspeed (**hence FMA VNAV SPD**). The rate of climb (and therefore the vertical path in space) is continuously updated and re-calculated during climb – but not maintained. This is why altitude/position predictions continuously change during VNAV climbs.

In contrast a typical VNAV descent begins prior to top descent, when VNAV calculates a three dimensional path in space-time which VNAV attempts to maintain during descent, **sacrificing speed where required in order to keep the Path. Typically this is required because of inaccuracies in the VNAV Descent Forecast Wind data.**

The situation at the beginning of this section is one of the exceptions - the occurrence of an At and/or Below restriction on the FMC Legs page during a VNAV SPD climb. If a limit becomes binding on the climb, VNAV will engage in PATH and level off to meet the restriction. If the Altitude Selector is in accordance with the restriction, VNAV will still engage in PATH but revert to VNAV ALT when the restriction is cleared, when VNAV wants to continue the climb – but is stopped by the Altitude Selector.

12. Climb, Cruise, Descent

12.1. **Filling in a Flight Plan**

The following is a recommended method for completing the OFP. Note that there are sections on completing the Dispatch Release Message page elsewhere (8.26 Final ZFW – What do we do with that?; 8.28 Load Sheet Arrives – OFP Dispatch Message page)

PLANNED	TIME	FUEL	CORR	BLK	FLT
TAXI		466		ARR 233	/
TRIP FUEL	12.37	105316		ETA 2251	BLK FLT
CONT	00.32	3500		ET	

ARR 0030					
DEP 1000	0958			1014	
ET 1400					

**Airborne** : The OFP Pushback (Out 09:58), Airborne (Off 10:14) are typically filled in after top of climb. At this point it's not a bad idea to make a note near this block of the ETA, based on Off (10:14) plus the OFP Flight Time figure (12:37).

Contingency Summary Page

The next step is to complete the EDTO block. The Off time from the Departure airfield propagates through a series of places in this section of the OFP.

**EDTO Entry/Exit** : The Off time is written under the ATD column to provide more accurate estimates for the first EDTO Entry and the last EDTO Exit points. These can be defined through 671nm range rings on the FMC Fix pages based on the two selected airports. Note the airports used to define EDTO Entry and Exit may not be EDTO alternates themselves.

**EDTO Alternate Validity Periods** : This section can be used during pre-flight weather and NOTAM review as a guide to validity period requirements. Once airborne, use the Off time (more correctly the difference between Off and Sked Out time) to update the Earliest and Latest ETA's for the EDTO alternates.

**Critical Fuel Summary** : Here the provided EET figures are added to the Off time to

calculate estimated times for the Critical Equi-Time points of between the various EDTO airports. These times can be placed in the fix pages for a reasonable representation of the ETP's between enroute EDTO airfields during cruise.

Navigation Log – Waypoint ETA's

Once airborne, the Navigation Log should be completed for the waypoint ETA's. The Airborne time (10:14) is placed at the top of the first page, and then a column of additions takes place down to the last page of the Navigation Log.

A crosscheck at the bottom of each page of the Navigation Log (including the last) ensures that calculation errors are not carried through the flight plan to the cross check at the end.

The ACARS COM Company Departure report contains the fuel on board as the aircraft commences the takeoff roll. This value is a meaningful cross check against the first REMF/MINR at the top of the first page of the Navigation Log.

V AUSTRALIA CONTINGENCY SUMMARY PAGE

---

EDTO INFORMATION

EDTO ENTRY	LAT/LONG	ATD	EET	ETA
SYD	S29 45.530 E163 24.03	1014	01.19	1133

EDTO EXIT	LAT/LONG	ATD	EET	ETA
LAX	N27 31.728 W129 04.59	1014	11.04	2118

EDTO ALTERNATE VALIDITY PERIOD

SYD	1014	EARLIEST ETA 1000Z	1014	LATEST ETA 1543Z	1557
APW	1014	EARLIEST ETA 1541Z	1555	LATEST ETA 2020Z	2034
HNL	1014	EARLIEST ETA 2020Z	2034	LATEST ETA 2344Z	2358
LAX	1014	EARLIEST ETA 2344Z	2358	LATEST ETA 2344Z	2358

CRITICAL FUEL SUMMARY

EDTODP1 CRITICAL POINT SYD -APW -EET 02.11 ETA 1225 FUEL RQD 52401  
W/C TO SYD M006 EET 3.32 W/C TO APW P002 EET 3.30 DIV FUEL 28079  
AT LAT/LONG S25 58.46 E171 36.1 - 99 NM BEFORE NFFF04  
ATA/FUEL REMAINING AT CP/ETP ...../.....  
FUEL IN EXCESS TO CP/ETP REQUIREMENT - 65920

EDTODP1 CRITICAL POINT APW -HNL -EET 06.49 ETA 1703 FUEL RQD 92490  
W/C TO APW P011 EET 3.31 W/C TO HNL P000 EET 3.31 DIV FUEL 28142  
AT LAT/LONG N01 42.62 W158 38.2 - 252 NM BEFORE 05N56  
ATA/FUEL REMAINING AT CP/ETP ...../.....  
FUEL IN EXCESS TO CP/ETP REQUIREMENT - 25828

EDTODP1 CRITICAL POINT HNL -LAX -EET 10.05 ETA 2019 FUEL RQD118031  
W/C TO HNL M014 EET 3.39 W/C TO LAX M001 EET 3.39 DIV FUEL 28824  
AT LAT/LONG N22 16.12 W136 58.0 - 474 NM BEFORE 27N30  
ATA/FUEL REMAINING AT CP/ETP ...../.....  
FUEL IN EXCESS TO CP/ETP REQUIREMENT - 260

V AUSTRALIA NAVIGATION LOG

POSN	ROUTE	MORA	FL	WIND	MTR	TAS	DIS	TIME	ETA	ATA	REMF
FIR	LATITUDE	LONGITUDE			TTR	GS	RMD	ACTM	RTA	APL	MINR
YSSY									AIRBORNE 1014		114.8 Dep: 118.3
SY	DCT	59 CLB	33/002	026 23	0	1	1015				+3.5
	S33 56.6 E151 10.8			040 23	6622	0001					114.6
DIPSO	G595	59 CLB	27/010	075 281	45	9	1024				111.4
YBBB	S33 54.4 E152 04.3			087 291	6577	0010					FL.....

LAX	V25	124 DSC	03/002	066 363	14	3	2215				87
	N33 56.0 W118 25.9			081 361	1	1237					9.9
											63
KLAX					1	000	2215				9.5
	DESTINATION MANUVR INCLUDED										1329 ✓
	N33 56.6 W118 24.4										1329 ✓
											80.8
											FL.....
											1014
											1329 ✓
											TOTAL TIME 1237
											1014
											2215 ✓



**Navigation Log – In flight record**

The Navigation Log pages of the OFP should form a Log of the Flight. At each waypoint that is passed in flight, the actual time and fuel on board (FMC calculated figure) should be recorded in the space provided.

Once the Rest Pattern and EDTO data has been calculated, writing these times on the OFP Nav Log page can serve as useful reminders in flight for these events.

Additional events can be logged by a conscientious crew. The intent of the navigation log is to provide the crew (or the relief crew) with the means to ascertain what happened previously; it also allows a follow up process to evaluate the flight after the event.

V AUSTRALIA NAVIGATION LOG												
POSN FIR	ROUTE	MORA	FL	WIND	MTR TTR	TAS GS	DIS RMD	TIME ACTM	ETA RTA	ATA AFL	REMF MINR	
	LATITUDE	LONGITUDE					FULLNAME					
NFFF6	DCT		41	310	27/082	054	503 168	17	1021	1029	102.2	+3.1
NFFF					067	574 5963	0117	.....			99.1	ETP 1103
1045z → 330 due ATC	S29	54.6	E163	00.0							FL 310	
					200/45	515						
NZZ00	DCT		23	310	27/078	066	501 306	32	1103	1101	96.8	+2.9
CPDLC NZZ0					065	573 5657	0149	.....			93.9	
	S27	45.8	E168	16.8							FL 330	
5565 sel /3457	27870	DCT	16	330	25/078	063	499 102	11	1114	1113	95.3	+3.1
					064	576 5554	0200	.....			92.2	W/Up 1130
126.25 @1130z	S27	00.0	E170	00.0							FL 330	
NFFF0	DCT		10	330	24/071	043	500 204	21	1135	.....	.....	
NFFF					054	569 5350	0221	.....			88.9	

- ATC Frequencies VHF/HF.
- Direct Routings
- CPDLC Logons and Transfers
- Enroute Climbs, Descents, Speed and Time constraints
- Off route diversions due weather
- Updated Wind Uplinks

Apart from flight navigation events, the OFP is often used to record other flight related events such as push back delay factors, passenger/cargo loading issues, passenger medical issues, etc.

See 14.5 OFP Completion Post Flight.

**12.2. EDTO Critical Fuel Check**

EDTO Additional Fuel (EDTO ADDNL) is planned when the fuel required to complete the most critical EDTO diversion from an ETP is less than the fuel required to continue the flight under normal operations and land at the Destination with FINAL RSV + ALTN fuels intact. Typically this occurs on sectors where the distance between the Destination and Alternate is relatively short.

ALTN WA/IFC	00.00	0
FINAL RSV	00.30	2862
EDTO ADDNL	00.39	4121
ADDNL	00.00	0

When EDTO Critical Fuel is present on the OFP, it's good practice to check and occasionally monitor the margin between EDTO Diversion Fuel and Estimated Fuel On Board at the most fuel critical ETP (usually the last one).

The OFP Navigation Log Minimum Required Fuel (MINR) column does not reflect any requirement for EDTO Additional Fuel, so regular fuel checks may not detect a developing low fuel situation with respect to EDTO diversion fuel. Additionally the OFP Navigation Log does not incorporate waypoints for the ETP's, so the FMC must be utilised to determine fuel at a crew constructed waypoint at the ETP.

The fuel critical ETP can be identified from the EDTO section of the OFP – if EDTO ADDNL was required, the **Fuel In Excess To CP/ETP Requirement** will be **Zero**. This waypoint needs to be

EDTODP1 CRITICAL POINT HNL -LAX -EET 10.05 ETA 2019	FUEL RQD118031
W/C TO HNL M014 EET 3.39 W/C TO LAX M001 EET 3.39 DIV FUEL 29824	
AT LAT/LONG N22 16.12 W136 58.0 - 474 NM BEFORE 27N30	
ATA/FUEL REMAINING AT CP/ETP	2021.1 29.2
FUEL IN EXCESS TO CP/ETP REQUIREMENT	260

constructed in the FMC – the most reliable method tends to be to use the OFP Lat/Lon co-ordinates. The ETP Lat/Lon waypoint can be entered in Fix page to highlight awareness of the aircraft approaching the ETP. Then as you near the ETP, line select from the Fix page into the Progress Page over the destination for a direct to fix Time/Fuel estimate to copy to the OFP.

It should be noted that in situations where the fuel estimate at the ETP calculated early in the flight is inadequate – the crew should commence a critical thinking process to determine the accuracy of the FMC estimate and the minimum required figure. As an example at the planning stage contingency fuel is required on the EDTO diversion; once airborne this requirement no longer applies.

Finally – the A1 requires that crew note the Time & Fuel On Board (Totalizer) be noted on the OFP at each EDTO Critical Point.

- 8.5.11.8 Fuel Monitoring**  
8.5.11.8.2 For the purposes of the Quality Assurance System, when overflying the computed EDTO Critical Point (CP) the flight crew must record the following fuel quantities:
- Fuel Onboard (FOB), based on FQIS;
  - Required minimum diversion fuel, based on the OFP Fuel Log. The fuel required at the most limiting position i.e. EDTO diversion point is provided in the Critical Fuel Summaries section of the OFP.



### 12.3. EDTO Critical Fuel – Do We Need It?

EDTO planning requirements specify fuel required for a Critical Scenario from the ETP between selected EDTO Alternates (whether more than one is selected). When finalising the fuel order, crew operating flights with EDTO ADDNL fuel should bear this requirement in mind when considering extra fuel.

However once dispatched, the flight is not required to meet this critical fuel requirement. In fact if the flight dispatches with minimum fuel and the flight proceeds normally, extra fuel available at the EDTO critical point will consist of un-used taxi fuel and any fuel saved enroute.

That said, it is incumbent on the flight crew to ensure the critical EDTO ETP is reached with an adequate minimum fuel. At planning stage critical fuel includes contingency, icing and other margins not required once airborne. Additionally for the critical fuel scenario to be realised in flight, the aircraft would have to suffer the relevant failure(s) at the ETP – a failure before or after the ETP would result in extra fuel being available to the flight.

Finally – the A1 requires that crew note the Time & Fuel On Board (Totalizer) be noted on the OFP at each EDTO Critical Point.

### 12.4. Use of VS to change Level at Higher Altitudes

See 12.5 Block Clearances. The use of VS/FPA (and even FLCH) constitutes a higher workload on the flight deck and comes with issues related to the use of IAS as a controlling auto flight parameter at high altitude. VNAV is generally the preferred solution.

### 12.5. Block Clearances

ATC Block clearances allow the aircraft to operate at any altitude within the cleared block limits. Climb or Descent within the block is at the behest of the crew. While traditionally used to maintain the most optimum cruise level to reduce fuel usage, block clearances have also been useful to find altitude between traditional RVSM levels that provide a smoother ride.

One crucial aspect of a block clearance during augmented operations is the clear communication of the clearance to the next crew during handover.

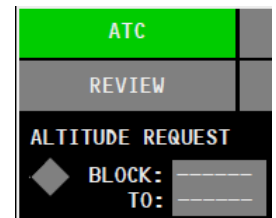

#### VNAV to Change Level

For altitude changes of 100 ft in the block level, VNAV provides the lowest workload solution through a simple twist and press of the altitude selector. The FMA does not change and the FMC Cruise Altitude is updated automatically. Thrust increases to maintain the FMC commanded MACH while the elevators pitch up to climb the 100 ft to the next level. Thrust and pitch change are minimal resulting in smooth ride for the passengers. Altitude changes of 200 ft or more however will result in the usual two rounds of FMA changes and the application of more thrust and pitch.

#### AFDS Basic Modes to Change Level

For level changes in excess of 100 ft in the block, some crew prefer VS +100 fpm (or FPA +0.1°). This is a higher workload/higher risk solution and it should be noted that any time a basic AFDS pitch mode is used at higher altitude, the AFDS Thrust Mode will default to Indicated Airspeed (IAS) – **this should be changed to Mach**. IAS as a commanded auto-throttle parameter during level changes at high altitude can expose the aircraft to high and low speed limit excursions. Note also that the FMC Cruise Altitude will need to be updated during the level change – this can be done anytime by pressing the altitude selector. When the level change is complete – even if another level change is expected shortly thereafter – the AFDS should be returned to VNAV PATH.

In essence, use of VS/FPA (and to a lesser extent FLCH) at higher altitudes to change levels is considered a high workload solution to a problem that VNAV was designed to address with **greater ease**.

### 12.6. Updating FMC Winds

The winds provided to the FMC through ACARS uplink are updated at Nav Services every 6 hours. The updates can take up to an hour and should be complete by **0600z, 1200z, 1800z and 2400z**. If you believe your winds are out of date **and** inaccurate, a request for a set of updated winds from the CDU LEGS Route Data page can assist.



Note that you can pre-select the levels in the LEGS page you wish to receive the winds at. This **is best** done by deleting ALL the existing levels in the LEGS RTE DATA Waypoint WINDS page in the FMC, replacing them with your own (nil wind will show and these levels will propagate forwards and backwards through the FMC LEGS waypoints), executing the modification and then requesting new winds. The uplinked winds will be appropriate to the entered levels.

You might want to do a route copy before you undertake deleting all the winds out of the FMC, just in case the new ones don't come down ...

12.7. EDTO Plotting Chart

The A1 requires the completion of the EDTO Plotting Chart for each EDTO flight. Ideally this is completed pre-flight, but can be left to be completed before EDTO entry. A suggested representation of the required positions is below.

When marking the route to be flown, include the names of **Waypoints** (ELKEY, 20N30, etc) as displayed on the OFP, EDTO **Entry** (EEP) and **Exit** (EXP) Points and EDTODP's (Decision Points or ETP's). Indicating at the ETP's the two EDTO airports considered can improve subsequent situational awareness when reviewing the plotting chart. Note that while the flight may pass in and out of EDTO threshold range (671 nm) of various airfields enroute – only the first EEP and last EXP need be plotted on that chart.

Finally, when plotting the ETP with critical fuel requirement (normally the last ETP on a flight inbound to KLAX, see **12.2 EDTO Critical Fuel Check**) – fuel required to divert from the ETP to the EDTO Airfield – highlights the critical nature of that particular ETP.

**Preparation of the Plotting Chart**  
The plotting chart is prepared considering the initial data and information defined above; it will be complemented by adding the following additional information available after the printing of the OFP:

- Area of Operation (if different from the charted information);
- Planned route/track and adjacent tracks in case of an Organised Track System (OTS);
- EEP, ETPs, CP, EXP, EDTO segment(s), Navigation monitoring symbols.

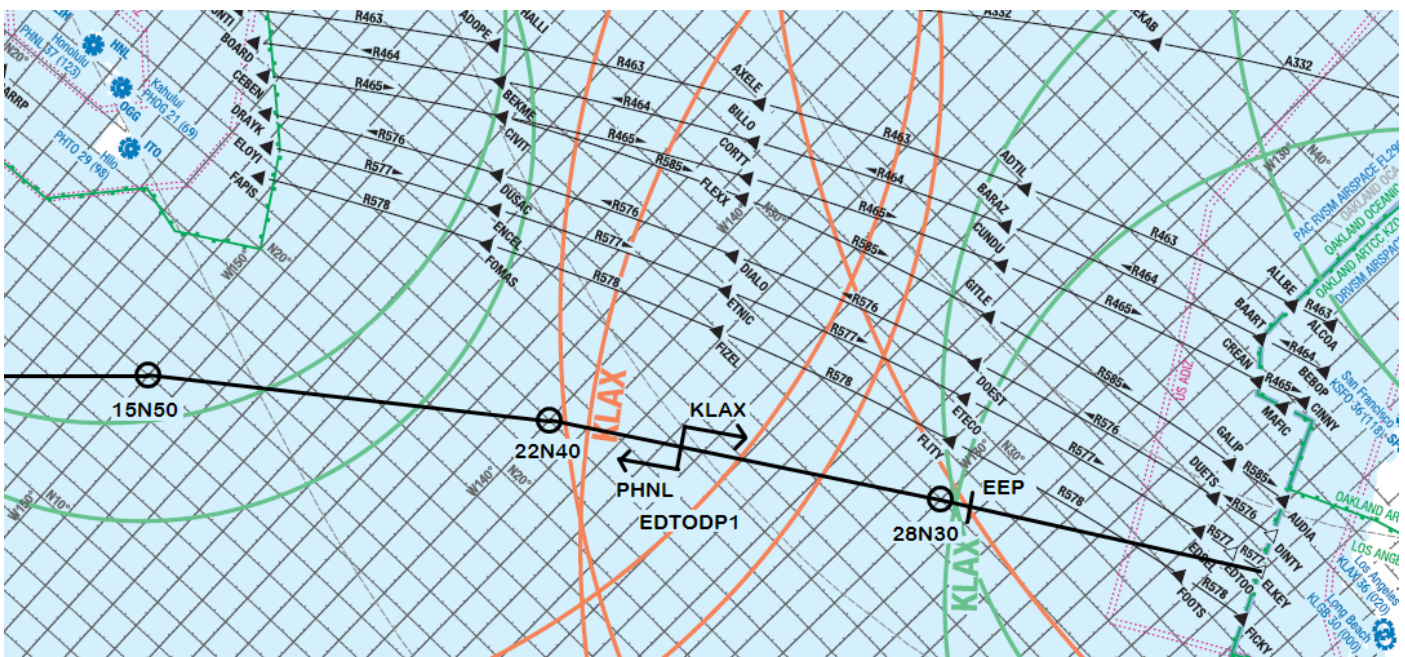

12.8. Route Offset via Track/Heading Select – Not via LNAV

The Route Offset feature of the FMC is used quite often during line operations. However when manoeuvring across to the new offset route, **crew should not** allow LNAV to self position across 20 miles of airspace to the new route – usually Track or Heading Select is used to positively control the aircraft to the new route. Don't forget to arm LNAV when your intercept heading/track is set.

12.9. Step Climbs – OFP vs FMC (Optimum vs Recommended vs STEP)

Crew should refer to the Boeing FCOM and FCTM for a full discussion of step climbs. What will be discussed here is partly a summary, partly a response to questions encountered in this area during line training/line observation.

“The OFP is the Most Accurate”

This is generally correct in that (in most cases) the computers and software used to calculate the vertical profile of the OFP are far more sophisticated than the computer and software found in the FMC. The flight planning system has access to a more complete performance database profile of the aircraft and a better level of detail of wind data that is accessible onboard. That said there are factors which can affect the accuracy of the OFP, post production. Alternative routes, significant weight and wind changes are amongst them.

**Winds :** The winds used to calculate a Long Haul OFP can be anything up to 9 hours old at Top of Climb, much older down route. If the crew have reason to suspect that the wind profile used in the OFP is significantly *different* than that on the OFP, the FMC (with updated ACARS winds) becomes your only remaining solution. Admittedly this is pretty rare, but does happen. Note I said “suspect the winds are *different*” rather than *old*.

**Weight :** The OFP is prepared for a specific aircraft weight (actually landing weight, flown backwards). If a significant ZFW change is involved, along with a significant change in Fuel Load, the OFP can be slightly inaccurate. It should be noted that the kind of weight changes that would significantly affect the accuracy of the OFP **cruise** climb profile should probably have required the crew to order a new OFP...

**Speed :** The OFP’s are typically based on minimum cost. Anytime you choose to fly a fixed speed schedule (faster to make time, slower to make fuel) the overall cost of the flight increases, and the FMC alters it’s OPT/REC/Step climb recommendations based on this speed schedule. The OFP climb points therefore become less relevant to the new type of flight being undertaken.

**FMC Winds – Forecast vs Actual**

The FMC winds are uplinked during pre-flight, and therefore might well be more up to date than those on the OFP, although not necessarily significantly different. Additionally, crew can request updated winds in flight (see 12.6 Updating FMC Winds). When using wind in the calculation, the FMC uses a mixture of 99% IRS Wind (Actual) and washes it out over approximately 600nm to 99% Forecast wind. This washing process is not linear – at approximately 200 miles, less than half the actual wind is used in the calculation. As soon as a higher level is being considered by the FMC – only forecast wind is used. The FMC does not wash actual wind up or down through levels.

**FMC VNAV CRZ OPT (Optimum Altitude)**

When operating in a block clearance, crew will often follow the FMC VNAV CRZ page OPT value, stepping up 100 ft at a time. However the OPT value takes only Cost Index (or selected speed), Weight and Temperature into account – there is no concept of Wind in the OPT value. As such crew may well be costing the flight fuel and time (and cost) by not following a wind based recommendation.

**FMC VNAV CRZ RECMD (Recommended Altitude)**

The Recommended Altitude includes wind and the OPT calculation to advise the best level for cruising for the next 500 miles or so. RCMD does not look beyond that in recommending altitudes, so potentially it could recommend a climb into a (much later) increasing headwind. Standard use of Actual/Forecast along track, up and down apply, and the altitude is based on various combinations of current cruising altitude and the entered STEP size. It should be noted that RECMD can also recommend a descent to lower level.

**FMC VNAV STEP TO Time/Dist (Step Climb Point)**

The STEP climb calculation completes the picture, using all available information of the OPT calculation and actual/forecast wind along the entire route stored in the FMC, in conjunction with current cruise altitude and entered STEP size to advise the best point at which to commence a climb to the next altitude. Crew should have a valid reason before choosing to deviate from the recommended FMC Step Climb points. It’s worth noting that the OFP is not capable of recommending climbs between waypoints whereas the FMC does. On the long legs between waypoints over the Pacific, this can be a significant factor in choosing FMC Steps over the OFP.

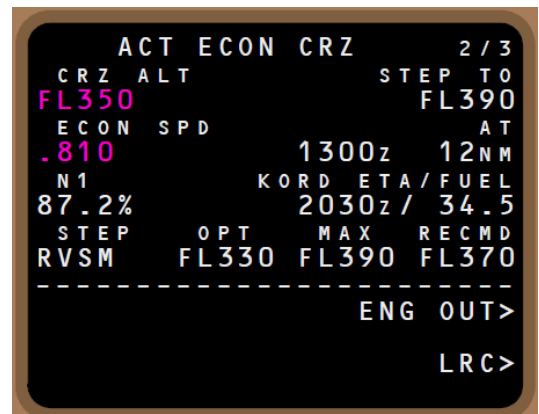

## 12.10. Crew Handover Briefing

The operating crew will conduct a briefing as part of the handover process to a relieving crew on augmented operations. The content of the briefing will vary depending on the circumstances of the flight, but the following points should be considered. This brief (like all briefing) benefits from a quick review prior to the arrival of the next operating crew on the flight deck. A review of EICAS (Recall/Status); ATC COMM (communication history, outstanding ATC Requested Reports), EDTO Alternate Weather and OFP Fuel/Time progress covers most of the regular briefing areas.

- **Aircraft** : Aircraft Serviceability (Recall/Status), OFP Fuel/Time progress, etc.
- **ATC** : Current VHF/HF/RTP usage, outstanding ATC requests (FIR frequency changes, CPDLC requests report back on route, Speed/Altitude requirements, Block Clearances, etc)
- **Route** : Route related issues such as significant terrain/escape routes, route offsets for Weather/SLOP, EDTO status (position relative to ETP, EDTO Airfields, etc),
- **Weather** : EDTO Forecasts/Obs validity & content, any updated Destination/Alternate weather, **FMC Wind Uplinks**
- **Cabin** : Review any significant cabin communications/events, status of cabin crew rest (who's acting FM), etc.
- **Other** : Other significant aspects of the flight the incoming crew should be aware of, such as Company messages.

During crew changes the speaker should be on to ensure communications continuity, the AP must be engaged and each crew area should be neat and tidy with maps and documents in their standard locations. Note that the A1 forbids any crew change below 10,000 ft; any change of Aircraft Commander below FL200.

Prior to leaving the flight deck, the PIC should consider discussing with the operating flight crew the severity of any non-normal events that require PIC notification and the level of operational decisions that require PIC authority.

## 12.11. Totalizer vs Calculated Fuel

Totalizer fuel is displayed on the EICAS is a straight representation of the aircraft FQIS.

Calculated fuel (which is the only value the FMC uses for fuel prediction) is based on Totalizer when the first Fuel Control Switch is selected RUN – from this point forwards the total is reduced by measured fuel flow through the Fuel Control Units.

Most flights are subject to differences between Totalizer and Calculated Fuel. Significant differences (4 tons or so) generate a FUEL DISAGREE message which may well indicate a fuel leak – but typically differences of up to 1 ton are not unusual.

The **question** of whether to record Totalizer (from the EICAS or FMC Progress Page 2) or Calculated on the OFP is often debated. Some points to consider ...

### In Flight Fuel Recording

Since the Totalizer measures a large value for most of the flight (fuel on board) while the Calculated measures a much smaller value (fuel flow through the FCU nozzles); the Totalizer is subject to acceleration and turning errors (despite the baffles in the tank) – generally Calculated Fuel from the FMC is a more accurate reflection of fuel state. Running a dual column on the OFP of both Calculated and Totalizer tends to bear this out with the Calculated Fuel indicating a general trend with variations that reflect level/speed/wind changes, whereas the Totalizer fuel track shows variations that are difficult to explain.

### Arrival Briefing Fuel

The difference between Calculated and Totalizer (**viewed on Progress Page 2**) is worth considering as part of your Arrival Briefing. Some pilots focus exclusively on FMC predictions when considering low fuel operations into destination. Differences between the Calculated (FMC) and Totalizer fuel can make the operation less conservative – resulting in either an unintended commitment to destination, or an early diversion to alternate.

While the Calculated is generally lower than the Totalizer at this point, a (much) higher Calculated Fuel figure could be corrected by re-setting the Calculated figure to the Totalizer value in the FMC. This is done by deleting the Fuel Figure represented on the INIT PERF page. This should only be considered if the Calculated value is considered to be in error.



## 12.12. HF Radio Usage

HF usage is taught during line training. The following points are worth considering.

**“Brisbane Radio, Brisbane Radio, Vee-Oz Two Datalink on Five Six Three Four ...”**

- Using the Left RTP for HF-L and the Right RTP for HF-R assists in avoiding confusion.
- Using HF-L for the primary ATC frequency and HF-R for the secondary also helps. Having the secondary on HF-R means the frequency is available for SELCAL in case the primary has failed.
- When given 4 frequencies (such the initial contact with San Francisco Radio providing a changeover at 140 West) setting both Primaries in HF-L (140W frequency in the Standby) and the Secondaries in HF-R again keeps a familiar usage pattern.
- Remember ATC will have a squelch facility in place on HF. As such the first syllable or so of a transmission may be lost (hence the “Brisbane Radio, Brisbane Radio ...”). Also leaving gaps between the words of your call means some words may be lost as the squelch breaks up your transmission. So slow your speech down, speak a little louder and run your words together a little.
- Initial calls to ATC on HF should include the HF frequency being used. ATC often monitor more than one HF frequency at a time and it can be a challenge to work out which frequency you’re calling on without this.
- Adding “Datalink” to your call sign – assuming you have a CPDLC logon with the FIR you are trying to contact – reminds ATC of this fact (don’t assume you’re talking to the same ATCO running CPDLC).
- Initial calls should also be kept minimal in detail. Don’t make a lengthy position report and SELCAL request until you know they’re ready to receive it.
- And if you still can’t get through to Mumbai after 3 attempts, throw in the words “Transmitting Blind, Transmitting Blind.” That’ll do it.

## 12.13. VHF Radio/RTP Usage

There are three VHF Radios (L+C+R) and three Ratio Tuning Panels (RTP L+C+R) in the 777. As discussed in HF Usage, each RTP’s is capable of tuning any VHF/HF radio – which while useful, can lead to some confusion on the flight deck if used inappropriately. Based on A1 recommendations the three VHF radios are used as follows:

- **VHF L** : Primary ATC Communications
- **VHF R** : Monitor 121.5 / Secondary ATC / Company / ATIS.
- **VHF C** : ACARS/Datalink Communications.

That said, it often makes sense to use VHF-C for Company/Weather when VHF-R is in use for other purposes. Ensure VHF-C is returned to DATA to maintain ACARS VHF capability. As a specific example – during pre-flight, taxi or descent the CM3 is often charged with updating the ATIS or contacting the Company. This is best done with minimal disturbance to the operating pilots by the CM3 taking VHF-C out of DATA to listen/transmit, and then pass the required information onto the operating crew.

Note that the Center VHF has a poor range airborne in comparison to VHF L/R – this is reversed on the ground.

### Offside RTP Usage

By convention RTP-L is used for tuning VHF-L and similarly with RTP-C/VHF-C and RTP-R/VHF-R. Offside tuning of VHF radios through another RTP is a useful feature but can lead to confusion on the flight deck. If you’re using an RTP for offside tuning, ensure it is returned to the correct onside tuning state upon completion of use. Offside Tuning of VHF-L (Primary ATC) or using RTP-L for offside VHF tuning is **not** encouraged.

### VHF Squelch Disable

The squelch feature of the three VHF Radio’s can be disabled using the RTP’s. Push and hold the Radio Tuning Switches (VHF-L/C/R button) to disable the associated VHF Squelch.

- VHF-L button on RTP-L for the Left VHF;
- VHF-R button on RTP-R for the Right VHF; and ...
- VHF-C button on **RTP-L** for the Center VHF (no idea why).

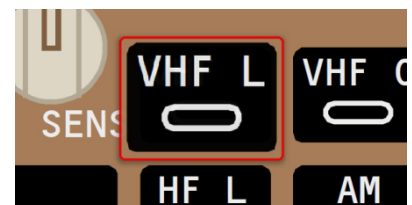



#### 12.14. Big Font, Little Font – the VOR/DME Ident

The Boeing nomenclature for displaying VOR/DME idents on the Nav Display can be misleading, in the least. The VOR/DME receivers are tuned by the CDU's which then seek to interpret the received ident. Co-located VOR/DME transmitters include idents for both the VOR and DME (usually the same ident) with the DME ident audible at a higher pitch.



- If no ident is received, the ND displays the frequency of the tuned navaid.
- If the VOR ident is received (irrespective of DME Ident reception) a conventional (large font) ident is displayed.
- If the DME ident **only** is received, the ident is displayed in a smaller font.

The display of a smaller font ident is commonly miss-interpreted as an identified VOR. In fact it is an indication of the receiver's **inability** to identify the VOR. It should also be noted that the ident displayed by the CDU may not match the database stored ident for the navaid - with no visual indication of the miss-match.

#### 12.15. Setting up for Approach – PF or PM?

Setting up the FMC and the aircraft for the arrival is normally the task of the pilot who will be flying the aircraft on the approach. In this way the PF gets to make the various decisions associated with planning the descent and approach. Ideally the PF will hand over control well before top of descent (therefore becoming the PM) and will complete a setup and self-brief of the approach, considering all the factors from top of descent point, through STAR, Approach, Missed Approach, Runway constraints, taxi ways, parking stand, airfield characteristics, diversion fuel, etc. When this process is complete, control is handed back and the other pilot will check the FMC, prepare charts, etc for approach, and get ready for a briefing. This is also the process used when established in a holding pattern.

In cruise on a nice day, there is no hard requirement for this handover to take place. When the workload is low, top of descent is still far away and everyone is awake – PF can retain control for this setup as long as PF retains situational awareness of the flight. PF can also brief an arrival while retaining control – again with the same requirement to maintain situational awareness and function correctly as the PF during the setup/brief.

An alternative approach is utilised when FMC setup and briefing must be done during high workloads – such as a runway/approach change during descent, or a setup to be completed after a missed approach. It is always permissible for the PF to direct the PM to complete a setup for the approach, and then if appropriate to brief the PF on the setup. While this process works well for repeating an approach after a missed approach, when it comes to setup for a different approach to a different runway (either on descent or after a missed approach) there **is** still a requirement for a positive cross check of the FMC by the other pilot.

#### 12.16. Hand on the Speedbrake Lever

If the Speedbrake lever is extended, it is recommended for the PF to keep a hand on the lever until it is stowed again. This generally precludes the likelihood of levelling sometime later with simultaneous Thrust **against** Speedbrake and an EICAS **SPEEDBRAKE EXTENDED** caution message. If PF needs to switch something, dial something, or scratch something – once complete, a hand should return to the Speedbrake lever again.

#### 12.17. Stowing the Speedbrake near VMO/MMO

Stowing the Speedbrake, especially during descent, can result in a momentary speed increase beyond the design limits of the autopilot to counter. As such, when descending at high Speed/Mach with the Speedbrake extended, stowing it quickly can result in **a high speed limit exceedence.**

#### 12.18. Monitor Descent Profile

It is quite important to monitor VNAV's profile calculation on descent. VNAV is the result of a computer calculation and the old adage of Garbage In / Garbage Out holds true (who fed VNAV the garbage?).

This check is best done through the basic 3x Height calculation, with an allowance for deceleration. Generally at 320 knots, an additive of 20 miles (adjust for tail/head wind) is pretty good. At 250 knots, 8-10 miles in excess of 3x Height is sufficient. VNAV DESC Offpath Descent energy management circles can also be a useful tool if used properly.

### 12.19. No Published Transition Level

Some Countries/Airfields do not publish a fixed Transition Level on the LIDO Approach charts – in this case a Transition Altitude is published, with the Transition Level as (ATC), often advised by ATIS.

<p><b>TRL ATC TA 8000</b></p>
-----------------------------------

The FMC stores the transition level of the destination airfield in the VNAV DESC FORECAST winds page.

When no Transition Level is published – the FMC will have the Transition Altitude value stored as the Transition Level instead. The threat here is that if the aircraft levels off at a flight level instead of the Transition Altitude during descent, the FMC will not advise the crew of the requirement to change to QNH via the PFD indications. If the ATIS broadcasts a Transition Level – this should be set on the VNAV Descent Forecast page when received.

### 12.20. FLCH Descent at 240 Knots

The FMC commands descent below 10,000 ft at 240 knots by default in order to be in compliance with the 250/10,000 speed restriction while still allowing vertical manoeuvring capability for tactical use by VNAV PATH. In PATH, VNAV will increase speed by up to 10 knots below 10,000 ft in order to compensate for an above path tendency

Crew transitioning to FLCH SPD for more direct control of the descent – particularly in tactical situations such as Off LNAV path vectoring by ATC – are under no obligation to reduce to 240 knots. FLCH is a speed mode and as any variation from selected speed is minimal – 240 knots is unnecessarily.

### 12.21. Setting Vref Early

Selecting and entering a Vref into the FMC is typically done as part of the setup prior to the Arrival Briefing. There are no specific restrictions or guidelines – crew can use the weight displayed at the time and update later (or not); use estimated fuel burn and the current weight to gain a more accurate Vref (or not); you can check the weight you calculate against the OFP revised Landing Weight – or not.

Setting Vref significantly early in the flight (for example prior to going for second rest as the operating crew) exposes the operation to the potential risk of a diversion into an enroute airfield with the incorrect Vref set. Hopefully this would be caught by the crew as part of the descent preparation into the new airport – but some airlines have a specific prohibition on setting Vref earlier than the arrival briefing. Crews are recommended against setting Vref for approach much earlier than the Arrival Briefing.

### 12.22. Enroute CDL Performance Penalties

#### Dispatch

Enroute CDL performance penalties are expressed in terms of fuel flow decrements, with a conversion factor specified in the CDL introduction (eg: 0.25% / 454kg). SABRE's Dispatch Manager has performance PDA and Drag Factor penalties Climb, Cruise Descent and Holding – although only Cruise is represented on the OFP.

See 8.18 Application of CDL Performance Limits for guidance. Ensure the OFP reflects the appropriate performance decrements for the CDL Defect.

#### Airborne

If crew are concerned about cross checking the performance impact of a significant enroute climb performance penalty, there are a couple methods of achieving this.

Crew could temporarily increase the ZFW of the aircraft in the FMC to obtain recalculated Maximum Altitude values – the displayed limit will be conservative as compared with the true impact of the performance penalty. Don't forget to change the ZFW back to the correct load sheet value.

In order to assess the single engine impact of a performance penalty, the VNAV Engine Out prompt would need to be selected after augmenting the ZFW in the FMC – Single Engine altitude capability can be obtained without executing the Engine Out modification.

Finally, QRH data can be obtained by augmenting the actual weight of the aircraft when using performance lookup information in the QRH.

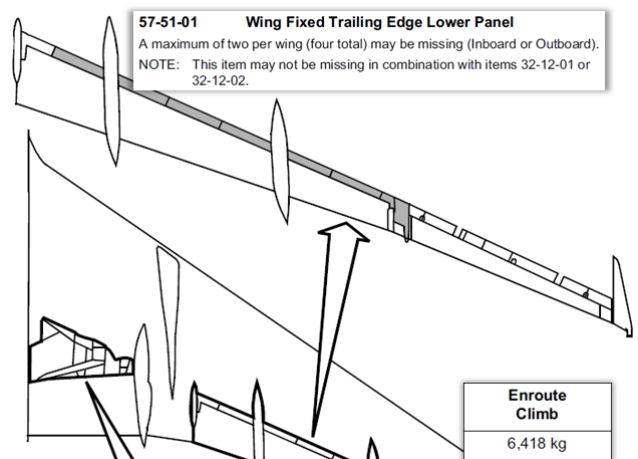

### 12.23. When do you do the Recall and Notes?

Generally it is **considered** incorrect to Recall the EICAS and review the Notes during the Descent checklist. The ECL NM checklists are intended to be called for and completed when the items are done. The Recall and Notes are actioned in the middle of the NM Descent Checklist typically because they were forgotten by the PF during descent/approach preparation and the arrival briefing.

DESCENT			
Recall .....	Checked		PF
Notes .....	Checked		PF
Autobrake .....	_____		PF
Landing data .....	VREF____, Minimums____		PF
Approach briefing.....	Completed		PF

The ECL is a clever tool that incorporates a number of human factor/human error philosophies, allows for multi (relief) crew, failures just before landing, as well as failures that occur hours before the preparation for the approach, potentially to the relief crew. It's not perfect and is meant to assist airmanship, not replace it.

As such the function of the ECIAS Recall is relatively clear. As specified in SOPs, a Recall is done with a clear EICAS message display, the Cancel/Recall switch is pressed, the word "**Recall**" is announced and any displayed failure messages are reviewed and the implications assessed. When complete, "**Cancel**" is called for and the Cancel/Recall switch is pressed to leave a clear EICAS message display.

The ECL Notes page performs a similar function. Notes that impact on the subsequent operation of the aircraft – whether cruise, descent, approach or landing – are collected from **Completed** (not overridden or reset) NNM checklists for later review by the crew. Notes from multiple checklists, notes affecting crosswind limits, missed approach configuration, the availability of hydraulic services (brakes, nose wheel steering, etc) all collect in the ECL so that the PF will have a comprehensive list to consider when preparing for the approach.

Please note that we are now moving away from specified Manufacturer or Airline SOP and into an area of personal/common technique. A suggested way of incorporating the Recall / Notes **ECL NM Checklist** item into Normal Operation is as follows.

#### Approach Preparation

As part of preparing for the approach, the PF should **Recall**, read and **Cancel** the EICAS with or without the involvement of the PM (ideally with). PF should then move into the ECL Notes page and assess the impact of those notes on the approach and landing to be flown. Note that if the Recall was clear there are not usually any Notes.

In extreme cases, Notes can dictate runway, approach or even airport selection. As such, beginning your approach preparation with the Recall and Notes can save significant time later. This technique follows the CRM methodology of allowing for NNM operation during NM operation through the **incorporation** of good habits. If you run the Recall and check for Notes during the preparation for every normal approach, you will pick them up when preparing for an approach after a NNM event.

When the ECL Notes Page is complete, leaving the Descent Checklist displayed (which will come up when you press the ECL switch to display the Notes page) as a reminder to both do the checklist later, as well as incorporate the Autobrake and Landing Data in your approach preparation.

#### Arrival Briefing.

When the setup is complete and the PM has checked the FMC and organised that side of the flight deck, the Approach Briefing can begin. Since the preparation for the arrival was best commenced with the Recall and Notes – the Arrival Briefing can also begin quite effectively the same way. If the PM wasn't involved with the previous review – run the Recall, read the messages, accept the Cancel instruction and clear the EICAS, and move onto the Notes.

Personally I commence an Arrival Briefing by copying the Descent Checklist : "**Ready for a Brief? Ok – Recall** (messages read, **Cancel EICAS** if necessary); **Notes** (no Notes, leave the Descent Checklist up); **Autobrake 3, Flap 30 Vref 145 knots, Minima 640 ft Baro**" ... And then on with the brief. Briefing Complete? -> Run the Descent Checklist as already displayed.

## 13. Approach, Missed Approach and Landing

### 13.1. VNAV Approach Validation

Before a VNAV approach can be flown, it should be validated by the crew. Typically this is done as part of the pre-arrival briefing preparation. The Boeing FCTM lists the basic rules required before using VNAV in approach mode.

The following are common errors when reviewing the LEGS page in preparation for a VNAV NPA approach

- Insertion of extra waypoints in the LEGS page.
- Alteration of altitudes at or after the FAF

The insertion of additional waypoints in the LEGS page can disrupt the approach logic of VNAV, along with Nav Rad auto tuning.

The alteration of altitude constraints in the LEGS page should be restricted to that necessary to compensate for cold temperature environments.

The crew should also take note of the waypoint after which the FMC LEGS page includes a published Glidepath – prior to this the aircraft will follow the more traditional VNAV descent path, rather than an approach glideslope.

#### VNAV Approach Validation

- Database selected Approach (Approach Overlay acceptable if it validates)
- Final Track on LEGS Page should match LIDO  $\pm 1^\circ$
- Distance FAF to Rwy/MAP should match LIDO  $\pm 1$ nm
- No minimum crossing altitudes infringed
- FMC Approach GP angle should be greater or equal to LIDO published GP
- The altitude at the MAP or the RWY waypoint should be appropriate for a straight in approach
- Approach Pre-Set RNP/ANP Check (GPS 0.3 or Charted; VOR 0.5; NDB 0.6)
- Vertical or Lateral adjustments from the FAF onwards not allowed.
  - Speed change at the FAF is acceptable
- The FMC approach design must be one of:
  - Approach with Published Glidepath (GP); or
  - Approach must have a RWxx waypoint coincident with the approach end of the runway; or
  - Approach must have a Missed Approach (MAP) waypoint prior to the approach end of the runway

Note that all V Australia approved RNAV approaches are validated with respect to WGS-84 airspace and there is no requirement to disable GPS updating.

### 13.2. VNAV Approach – No Path Indicator

Prior to commencing a VNAV approach, a quick look at the ND to verify the existence of the VNAV Descent Path Indicator and the position of the aircraft relative to the commanded path can save some significant embarrassment at the IAF - if the Path Deviation indicator is not displayed, the likelihood is that VNAV PATH will not engage or will not commence a descent at the IAF. Typically the ND Path Deviation Indicator fails to display when the FMC is in VNAV Climb or Cruise mode. This most commonly occurs in the case of diversions during climbs or when returning to the departure aerodrome. There are two ways to correct this situation.

One method is to insert the current altitude into the VNAV CRZ page. This will force the FMC from CLB to CRZ mode. As the aircraft approaches top of descent (which may well be the IAF), the FMC will transition into FMC Descent mode and the path deviation indicator will display. One of the risks associated with this method is potentially deleting an altitude restriction from the LEGS page if you choose a cruise altitude at or below such a restriction, typically the altitude at the IAF which could result in an early final approach descent.

A better method is to use the DES NOW prompt on the CDU VNAV DESC page. This forces the FMC into descent mode and immediately displays the ND path deviation indicator.

Awareness of the aircraft's position relative to the programmed descent path prior to final approach is crucial to successful VNAV Path engagement.

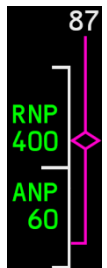

DES NOW > 

**13.3. Alternate MCP Altitude Setting Technique**

The Boeing FCTM requires the setting of all altitude restrictions (whether from ATC or a SID, STAR, Approach) in the MCP Altitude Selector during Climb and Descent, irrespective of the use of VNAV or Basic Modes (FLCH/VS/FPA). This requirement is relaxed somewhat when VNAV SPD/PATH is used and the altitude restrictions are closely spaced – the Alternate MCP Altitude Setting Technique.

**FCTM 1.37 : Alternate MCP Altitude Setting Technique**

- For departures, set the highest of the closely-spaced constraints.
- For arrivals, initially set the lowest of the closely spaced altitude constraints or the FAF altitude, whichever is higher.

**Note :** The Operator must approve the technique and crew must be appropriately trained. Additionally this technique may also be used for Tailored Arrivals (TA) regardless of how closely the altitude constraints are spaced.

- During Climb and during Descent between Top of Descent and the Initial Approach Fix (IAF) if “waypoints with altitude constraints are closely spaced to the extent that crew workload is adversely affected and unwanted level-offs are a concern” the **Alternate MCP Altitude Setting Technique** may be used.

**Non Precision Approaches**

Specifically for NPA’s this technique can be used with VNAV PATH engaged coupled to a correctly programmed set of FMC LEGS page altitude restrictions with a published glide path.

- Altitude constraints between the Initial Approach Fix (IAF) and the Final Approach Fix (FAF) that are “closely spaced to the extent that crew workload is adversely affected and unwanted level-offs are a concern” do not need to be set.
- Altitude constraints between the FAF and the Missed Approach Point (MAP) are not set where a published Glide Path (GP) angle is present on the LEGS page.

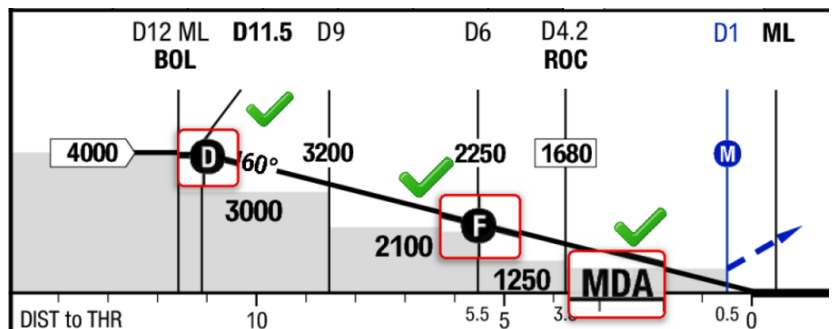

As long as the LEGS page validates and there’s a published glide path angle from at least the FAF -> MAP, the PF is required to set the IAF, the FAF and then the Minima.

IAF → FAF Intermediate altitudes may be set at the PF discretion – all care should be taken to ensure no intermediate altitudes are compromised – or captured.

**Setting Crossing / Nearest / Minimum Altitudes**

Note that the Boeing FCTM requires setting the **crossing altitude** – as such this would require setting 2250 in the altitude selector during the pictured approach. Since this is not possible (nearest 100 ft only) the other options are 2300 (conservative) 2200 (still above the published minimum) or 2100 – the published minimum. All are considered acceptable – **the requirement is for the aircraft to fly past the waypoint (ideally) at the crossing altitude, above the minimum crossing altitude.**

**13.4. Setting DH/MDA for Cat IIIB No DH Approaches**

Some crew set 0 (zero) as the DH for a Cat IIIB No DH Approach. This is technically incorrect and reduces the effectiveness of the DH/MDA selector for these approaches.

In fact, this approach has **No Decision Height**. As such the Minima MDA/Selector should be set to DH, the Cat IIIA DH set and the DH hidden from view – No DH. In the event of a reversion to Cat IIIA (Land2, Auto throttle Failure, etc) – the minima selector can be pressed and the Cat IIIA DH will appear. Note that the MDA can be set to the Cat I minima as well.



### 13.5. VNAV Approach – Early Descent

Leading on from VNAV Approach Validation is the often misunderstood early **VNAV Descent**. This occurs when a waypoint exists on the published approach that is not in the LEGS page.

In the example given, the FMC LEGS page includes **MMLSI (3000)**, **MMLSF (1680)** and **MMLSM (0480)** waypoints, with appropriate altitudes at each – note the altitude at MMLSM is the expected altitude as the threshold is crossed.

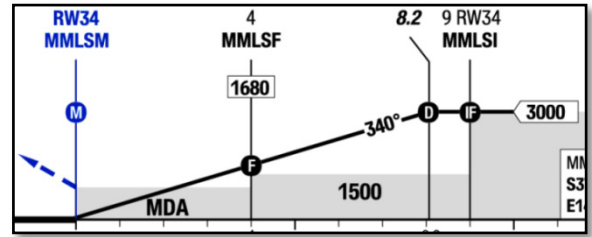

The published LEGS page glide path angle for this approach is 3° (2.99°) and commences from MMLSF – the FAF. As such prior to this point the FMC commands VNAV to follow the traditional fixed point to fixed point path. The **result** of this is that VNAV will commence the initial descent at MMLSI and will not wait for the 8.2 fix in order to establish 3°.

The ALAR program and general industry recommendations are for a stable 3° descent from the initial approach altitude. While technically not in compliance, this VNAV behaviour is considered acceptable, at least until the relevant VNAV approaches are re-coded with approach slope angles from the IAF. As long as VNAV keeps the aircraft above 1500 ft until the FAF (in this case, 1680 is what VNAV is aiming for) the best method is to stay hands off and monitor VNAV down the approach. Briefing the event as part of your arrival briefing is not a bad idea.

### 13.6. VNAV Approach – Speed Jumps Up

One of the more **disconcerting** occurrences associated with a VNAV Approach is the “jumping” of selected speed along with the associated increase in thrust and pitch as VNAV is engaged and the MCP selected speed window is closed by VNAV. Even if the PF is quick to re-open the window and reduce the speed, it’s a noticeable event to the crew (and passengers in the know).

The speed increases when VNAV is engaged because that’s what the PF has asked it to do – through the FMC. If before the VNAV switch was pressed the PF looked down at the FMC VNAV page (which should be VNAV Descent) to check the targeted speed, it would probably be 240 knots. As such when you engage VNAV – this is what it will try to do.

The only reason VNAV would not command this speed (which will of course be limited by the currently selected flap limit speed) is because a Legs Page speed constraint has become the commanding factor. This is often a default 170 knots either at the IAF or the FAF. However the point at which VNAV is typically engaged is prior to that point at which VNAV calculates a speed reduction is required to meet the 170 knot speed constraint – hence the speed increase. There are (at least) two solutions to this.

The first is to fly the entire descent and approach in VNAV. That way VNAV will not need to be re-engaged for the approach and the speed jump would not occur. This is actually the way the aircraft is designed to be flown. Unfortunately the designers didn’t quite account for the amount of off **path** LNAV/VNAV vectoring ATC usually provide, and so FLCH is still the mode of choice for many descents in to the initial approach.

The second method is to force the FMC into selecting the speed you want it to target when you anticipate **selecting** VNAV. Since this is typically about 2 miles before the IAF/FAF – it should be easy to predict. It should also be easy to work out what speed you’ll want “Gear Down, Flap 20”, Flap 20 Speed, Speed Brake armed, Checklist displayed, Minima set, VNAV pushbutton, “VNAV Path”, “Speed Intervene”. You want VNAV to target Flap 20 speed. In that case, program Flap 20 speed at the IAF/FAF **waypoint**. An additional precaution is to program that speed at the waypoint prior to the IAF/FAF – that way if you engage VNAV early for some reason, Flap 20 speed will still be selected. Note however ...

- **All VNAV approaches are flown with Speed Intervene active** – the speed is managed directly by the PF with VNAV PATH annunciated.
- If you want to fly the approach in VNAV, you are allowed to change the speed at the LEGS page IAF/FAF, but not the altitude – and neither speed nor altitude can be changed at any waypoint after that.

The practice of **pre-setting the appropriate approach speed in the VNAV Descent Page prior to engaging VNAV for the NPA is strongly discouraged**. This would need to be done during the run in at platform altitude to the IAF/FAF and apart from being a source of distraction during the busy pre-approach environment, if done incorrectly could well result in a low speed excursion for the existing flap configuration. Setting the speed on an appropriate LEGS page waypoint is the best practice solution and can be done at altitude during approach preparation.

### 13.7. MDA or MDA+50?

Usually a precision approach promulgates a Decision Height (DH) where the intention is that the decision to land or execute a missed approach is made as the aircraft reaches the minima. Consequently the minima is selected to ensure terrain clearance as the aircraft momentarily descends through the minima while commencing a missed approach.

Most non precision approaches promulgate a Minimum Descent Altitude (MDA) which is exactly that – if the aircraft descends below this altitude in IMC during the approach, terrain clearance is compromised. Accordingly a 50 ft addition to the MDA is made to ensure the missed approach from MDA will not compromise terrain clearance.

During circling approaches, the MDA is set in the altitude selector and the aircraft allowed to capture MDA and fly level in preparation for a turn to position for landing. As such, irrespective of the decision to land or go-around by the PF – the aircraft cannot descend below MDA, therefore there is no need to add 50 ft to the circling minima **as long as the flight path will capture circling MDA and not descend below it in the event of a missed approach at minima.**

There are hybrid approaches such as sidestep landings to adjacent runways where the decision to set MDA+50 or not may not seem clear. **Ask yourself this – am I going to fly level at the minima, waiting to intercept 3° to the landing runway, or do I plan on flying through the minima, because I'll already be on slope?**

- If a level flight segment at the minima is expected, use MDA, set it in the MCP and capture it at the minima with the AFDS – setting Missed Approach Altitude at ALT/VNAV ALT Capture. When ready to commence descent to the runway, disconnect the AP and truck on down.
- If (very) little or no level segment is required – set MDA+50 and re-set the MCP to the MAA at the appropriate time – don't allow the **AP engaged** AFDS to capture and fly level.

### 13.8. FLCH during NPA's

Often when a non-precision approach is going pear shaped and the aircraft **deviates** high on initial approach and not in VNAV PATH (such as VNAV ALT/SPD, or forgetting to set the MDA/Intermediate Altitude, or forgetting to engage VNAV approaching the IAF, etc) crew tend to revert to FLCH as a means of expediting their descent towards the required path. This is almost always a potentially dangerous action on the part of the PF. FLCH is not an approach mode and if the ALT selector is set below the minimum altitude for the approach segment, FLCH will take the aircraft below safety height. Subsequent action to set the Missed Approach Altitude during this descent can seal the fate of the aircraft.

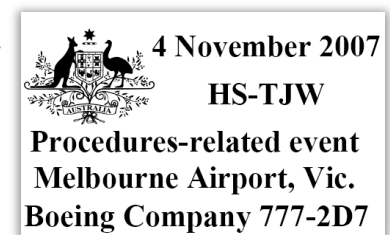

During such circumstances, the most reliable solution is usually to revert to set the altitude selector to the next constraint and initiate a VS descent with a rate of descent commensurate with the above path indication to expeditiously return to profile. As the intermediate constraint is approached and the aircraft is still not on path, the next constraint can be set. The approach should be terminated at 1000 ft AAL if not stable, earlier if it becomes obvious the approach will not be stable by 1000 ft, or anytime the crew **are** uncertain of their position with respect to the approach profile (or are below it).

An alternative technique is to engage VNAV SPD descent (lowering the altitude selector to the FAF or MDA and pressing the altitude selector is normally sufficient to achieve this) and use speed brake to achieve a higher rate of descent to regain VNAV PATH, which **will capture when the aircraft is within 150 ft of the programmed approach path. Crew must ensure that the LEGS page altitude constraints have not been accidentally cleared (such as through multiple altitude selector presses) otherwise a below safety height situation can occur.**

### 13.9. Modifying an Existing Hold

It's worth noting that you cannot modify an existing holding pattern once the initial fix has been over flown and the hold commenced. For example, if you are established outbound and wish to increase the holding time, you have to use Track Select to continue outbound (did you start a clock?) If you alter the holding parameters in the FMC, it then will overlay the new hold on the ND until you execute the modification, at which point the previous hold will remain. The new holding parameters will take effect once you transit the holding waypoint for the next hold.

This does not apply for holding entry – if you're still in the sector entry, you can modify parameters of the hold and the new hold will become active as you complete the entry.

### 13.10. Extending the Centerline

Typically in our environment your aircraft will be vectored towards final approach (or somewhere else) destroying the usefulness of the carefully constructed lateral and vertical path of the STAR and initial approach. At some point during the vectoring (earlier rather than later is usually best) PF may well want the approach/runway centreline extended. This ensures a reasonably accurate VNAV profile, good distance to run on the progress page and helps mitigate the risk of being vectoring inside a waypoint on final.

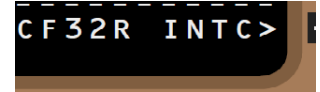

You could choose a waypoint from final on the LEGS page, selecting it to the top and enter the approach track as the Intercept Course To – but it's worth noting that the DEP ARR arrivals page has all of this in one button press, including taking you automatically to the LEGS page to check the result. This feature also includes updating the Destination on the RTE page where appropriate (as in return to departure).

As such a call from the PF **“Extend the Centerline”** would be followed by the PM selecting the DEP ARR 6R button, then checking the result on the LEGS page, and a prompt back to PF such as **“Five Mile Fix, 160 Inbound, Confirm?”**

### 13.11. VNAV ALT on Approach

A common occurrence during a VNAV Approach is the VNAV ALT capture event. It's important to understand what VNAV ALT actually is as an AFDS flight mode. If VNAV ALT is engaged (Climb or Descent, Departure or Approach):

- You **ARE** in VNAV (Thrust, Speed, Pitch from the FMC); and
- VNAV wants to Climb or Descend **NOW**; and
- The MCP Altitude Selector is in the way.

As such the first thing to do is alter the MCP Altitude Selector. On approach this typically means setting an intermediate approach altitude, or the Minima. While this frees up VNAV, this action will NOT commence the descent.

The next step is to press the Altitude Selector (**just once**<sup>1</sup>). This will force VNAV out of ALT and into either PATH or SPD. In either case you are likely to be high on the approach. How high above the VNAV path you are will direct VNAV into one of these two descent modes.

**VNAV PATH** : If you're now in PATH, this means that your recovery was completed within 150 ft of the calculated path. VNAV PATH will now reduce thrust (down to idle), **and increase speed if required** in order to regain the calculated vertical path to the next legs page altitude restriction.

**VNAV SPD** : VNAV is out of tolerance for a PATH engagement. Instead SPD mode will set idle thrust, pitch to maintain a descent at MCP speed and leave the aircraft to descend down onto the approach path. Note that you are **not** in the correct mode for the approach – although you are protected from descent below the FMC approach path. Should the descent be sufficient, PATH will engage as the calculated vertical path is approached. Should the VNAV SPD descent be inadequate, PF now has two options – increase drag (Gear or Speed Brake) or abandon the approach.

The determining factor in recovering from a VNAV ALT capture (whether at the IAF or down the approach) is the stabilisation requirement at 1000 ft. If the PF determines that the aircraft will not be stable by 1000 ft, the approach should be abandoned. If the aircraft is not stable at 1000 ft AAL, a missed approach should be flown.

### 13.12. “Are you ready for the approach?”

Perhaps even more than the “Can I close the door Captain” question, this question gets more crew into trouble in the simulator than any other, usually at a time when the crew think they really have a handle on the flight. When asked this question, anticipate being cleared direct to the IAF, with an immediate descent to the initial approach altitude, add into the mix Charts, FMC Setup, Briefings, Descent and Approach checklists, Aircraft position, altitude and configuration – then answer the question. Is one more trip round the holding pattern required to get it all done?

The most common manifestation of this error is holding in the holding pattern a thousand feet or more above initial approach altitude and advising ready for approach without sufficient track miles available to descend and configure in time for the IAF.

<sup>1</sup> See 3.6 Keep pressing that Altitude Selector ... NOT

### 13.13. Parallel Runway Awareness

Vectoring for final at airports with closely spaced parallel runways requires extra vigilance by crew. Overshoots of the centreline may or may not be accounted for by ATC – Crew should endeavour to avoid straying across the centreline into the approach of the parallel runway if possible. Note the use of LNAV to intercept final can be useful in this regard (see 13.14 LNAV into Localiser Capture)



### 13.14. LNAV into Localiser Capture

When vectored into a localizer associated with parallel runway operations, the AFDS LOC Capture logic can schedule up to two overshoots of the localizer dependant on the intercept angle, wind, groundspeed and other factors. This is not aberrant, but a programmed behaviour of the capture logic. However an overshoot of the localizer during closely spaced parallel runway operations may be less than ideal. In this situation, where the localizer centreline is available in the FMC, LNAV can be used to initially capture the localizer without overshoot, and LOC/APP engaged once the initial LNAV capture is complete. Crew need to ensure LOC is engaged (not just armed) once established, and an awareness of the glideslope is crucial to ensure an above path situation does not develop.

Additionally, caution needs to be used when using LNAV to capture the localizer track with LOC armed – such as when transitioning from a STAR into the initial approach. Even in today's GPS guided, RPN validated navigation environment, the potential for LNAV to take the aircraft on a gentle intercept of the inbound track, then parallel the approach without achieving localiser capture still exists. In V Australia aircraft, GS will engage and commence a descent without LOC capture. Naturally an FMA aware flight crew would note that LOC was armed but not engaged, but still ...

### 13.15. Localiser Approaches – FMC Selection

Typically a localiser approach is selected in the FMC as the ILS approach, then validated as an overlay for the Localiser Approach.

However sometimes there is a Localiser specific approach in the FMC (usually labelled LOC). Typically this occurs when the localiser approach varies from the ILS profile. If cleared for a Localizer Approach and there's a LOC specific approach in the database, it must be selected for the approach.

### 13.16. Arming Approach Mode

Selection of the APP mode push button on the MCP arms/disarms or engages/disengages AFDS LOC and GS modes, as well as isolating the electrical bus arrangement to ensure three autopilots have individual electrical power sources.



It is worth noting that the V Australia 777 AFDS will capture and descend on the GS prior to LOC capture. As a result of this feature, crews are often taught in the simulator not to arm APP mode until LOC capture has been achieved. One detrimental effect of this habit as common practice is that it is more likely to lead to regular occurrences of forgetting to arm APP mode.

Typically ATC (LAX is the exception) do not vector aircraft onto a localizer above the glideslope (that's left for Instructors in the simulator to do), so the trap inherent in the AFDS GS first feature does not normally present operational implications.

That said, in the situation where the aircraft is vectored onto the localizer close to (or above) the glideslope, the PF must decide on and implement an appropriate response to the early GS capture. This could be:

- **Allow the AFDS to commence the GS descent, monitoring for LOC capture.** In this case the aircraft must remain above MSA/LSALT until established within ½ scale deflection of the localizer. Part of implementing this course of action should be a verbal interchange between the PF/PM to ensure both are situationally aware of the descent in GS without LOC capture, and ideally establish a limit by which LOC capture is achieved, or the approach terminated.
- Advise ATC the approach cannot be commenced and ask for further vectoring.

Additional common practices related to the arming of LOC/APP mode are:

- Delay selection of LOC mode until cleared to intercept the localizer.
- Delay selection APP mode until cleared to commence the approach.
- Check for ILS ident and indications on the PFD when selecting LOC/APP mode to ensure the validity of the ILS signal.

While all of these common practices are good airmanship – none of them are to be considered binding requirements. Good aviation habits are often sacrificed to circumstances when actual conditions require.

### 13.17. Glideslope Intercept From Above

Intercepting the glideslope from above is typically not good airmanship and in some cases is prohibited by some airline SOPs - the **implied threat** is the potential to intercept a false glideslope.

However if the crew are confident in their situational awareness and in the circumstances that have lead to being above the glideslope, the following procedure can be utilised to minimise the risks of intercepting the glideslope from above.

#### AP Engaged

- Set the altitude selector to 1000 ft AAL (approximately).
- Ensure **LOC is engaged, GS is armed** and the aircraft is **ABOVE** the glideslope.
- Engage VS and select a high rate of descent (generally at least 1500 fpm is required).
- If the VS requirement results in idle thrust and an increasing airspeed, the use of some speedbrake can assist in regaining path. Note the FCTM recommendation against speedbrake at flap settings in excess of Flap 5
- Monitor the approach (especially vertical path cross checks) until GS capture is achieved.
- If it becomes clear that the aircraft will not be stable by 1000 ft AAL, the approach should be abandoned.

PF	PM
Arm APP Mode.	
Set MCP Altitude no lower than 1000 ft AAL.	
Engage VS Mode.	
<b>Warning :</b> Ensure Localizer tolerance is within limits before descending – ideally LOC should be captured.	
Set desired vertical speed.	Monitor progress of Glideslope closure. Call “ <b>Glide Slope Alive</b> ” when appropriate.
At glideslope capture, set MAA.	
<b>Note :</b> If GS is not captured (or will not be captured) by 1000 ft AAL – or if ALT engages – go-around.	

Sometimes the automation gets in the way of a relatively simple above glidepath correction. It may be simpler to disconnect the AP and push the nose down to establish the required descent rate for a glideslope intercept. As long as the A/Thr is in **SPD** mode on the FMA, it can remain engaged during this manoeuvre. As soon as GS has engaged on the FMA, the AP can be re-engaged or a normal manually flown ILS approach can be continued.

#### Manual Flight.

- Set the altitude selector to 1000 ft AAL (approximately).
- Ensure **LOC is engaged, GS is armed** and the aircraft is **ABOVE** the glideslope.
- Disconnect the AP and increase the rate of descent commensurate with the requirement to capture the glideslope.
- Speedbrake can be used to assist in regaining path. Again note the FCTM recommendation against speedbrake at flap settings in excess of Flap 5.
- Monitor the approach (especially vertical path cross checks) until GS capture is achieved.
- If it becomes clear that the aircraft will not be stable by 1000 ft AAL, the approach should be abandoned.

Potentially the PM could be utilised to engage and set VS to provide flight director commands to a glideslope capture point. However this increases the workload on the PM, reducing the PM’s capacity to monitor, without a significant increase in flight safety.

The monitoring of the aircraft’s vertical path and the maintenance of situational awareness is crucial at this time. If a below glideslope situation develops, a go around should be executed. Note that the use of FLCH in this situation is not recommended. **Apart from the Flight Safety implications of FLCH in this situation, it** is entirely possible that FLCH will not command idle thrust, while VS will do so if the descent demand requires it.

### 13.18. Circling Minima

Crews should note that the A1 (8.1.3.4.6 pp 8-48) requires a **minimum** circling altitude of 1000 ft AAL (**Airport Field Elevation**) and 5000m / 3 sm (US), over and above the LIDO published circling minima.

### 13.19. Circling approach positioning by triangles

The use of the aircraft symbol triangle on a 10 mile scale ND for positioning during a circling approach **can be** a useful **monitoring** technique – **but cannot be used as a replacement for timing**. Wind adjusted timing must be the primary positioning technique when conducting circling approaches.



### 13.20. ILS Approach to Circle

When conducting this approach, remember that the aircraft will not intercept the MCP Selected Altitude with GS engaged, and the only way to get the aircraft out of Approach Mode after 1500 ft AGL LAND 3 (such as to level off or turn to position onto downwind) is to turn both flight directors off AND disconnect the autopilot. As such it is best not to use GS for the approach vertical mode. The recommended mode is therefore VNAV or failing that VS/FPA. While LOC would be the normal mode, it's also acceptable to use LNAV to fly a Localizer as long as you ensure localizer tracking tolerance is maintained.

### 13.21. Autopilot and MDA

Without LAND 2 or LAND 3 (Approach Mode), the autopilot must be disconnected by 50ft below MDA. Some crew under training are quite slow to disconnect the AP after MDA – be careful you don't break this limitation.

### 13.22. Flt Director OFF at Minima?

The FCTM recommends that both F/D's be turned off and the PM F/D selected back on once the aircraft has left the MDA(H) after a basic modes (VS/FPA) non precision approach. The intent is to remove poor flight director command indications from the PF's PFD.

Leaving the MDA(H), disengage the autopilot. Turn both F/Ds OFF, then place the PM's F/D ON. This eliminates unwanted commands for the PF and allows continued F/D guidance for the PM in the event of a go-around when pitch or roll mode is changed. Complete the landing.

When using VNAV for the approach, the flight directors may be left on as long as the flight director indications will be correct after the minima all the way to the threshold. This means that the runway threshold (or equivalent) must be in the LEGS page as a waypoint, with the correct threshold crossing altitude. There are still some approaches that meet VNAV validation requirements, but in which the runway does not form part of the approach, or the altitude crossing restriction is inappropriate for the runway elevation – such as those with a missed approach that turn before the runway threshold. In these instances, both F/D's should be turned off and the PM cycled back on.

### 13.23. Unnecessary Actions during Circling Approaches

Flight crew should avoid unnecessary actions during circling approaches. Once the aircraft has broken off from this final instrument approach to position visually for landing, the crew should focus on manoeuvring the aircraft procedurally with respect to the landing runway, as well as maintaining visual contact with the landing threshold and/or approach area. The following actions have been observed during sim check/training. In most cases these actions are superfluous and in fact distract unnecessarily from the safe positioning of the aircraft for landing.

- Selecting the landing runway in the FMC
- Extending the centre line and other FMC lateral manipulations.
- Updating Fix page rings and bearings
- Altering MCP HDG/TRK and VS selections to provide Flight Director guidance after leaving circling MDA.

Some of these actions can provide extremely useful backup information to the PF/PM during circling approaches in minimal (5K) visibility. Without exception however alternatives can be found that can be pre-programmed and briefed in advance, and not impact on workload during the circling manoeuvre.

### 13.24. "Localizer" vs "Localizer Capture" (... and Glideslope ...)

The correct FMA call is "Localiser Capture" – not "Localiser". Localiser is a deviation call from the PM to the PF when a deviation from ILS centreline.

Similarly it's "Glideslope Capture" when annunciated on the FMA, and "Glideslope" when it's all going wrong and the PF is high or low on the ILS Approach. Even better is "Glideslope Capture ... Missed Approach Altitude Set."

### 13.25. Circling Approach : Descent from MDA using AP

A technique commonly taught during circling approach manoeuvring is to use the AP in VS or FPA mode to commence descent from circling MDA when turning Base on the visual circling segment. This technique reduces workload during the initial part of the visual circling/descent manoeuvre and allows the use of automation further into the approach.

#### Autopilot/Flight Director System

The autopilot must be disengaged before the airplane descends more than 50 feet below the MDA unless it is coupled to an ILS glideslope and localizer or in the go-around mode.

The first issue with this technique is that it contravenes the FCOM limitation on AP engagement during Non Precision Approaches – **the AP must be disengaged before the aircraft descends more than 50 ft below MDA.**

The second issue is that the PF is now in an open descent in a non-precision AFDS mode with no safety floor – no MCP Alt selector to catch the aircraft, no VNAV PATH to guide to the runway threshold. While initially suitable, VS quickly becomes patently unsuitable as the vertical path begins to require the detailed adjustment only manual flight can provide – the same issue applies to lateral nav, which is typically Hdg/Trk Select at this point.

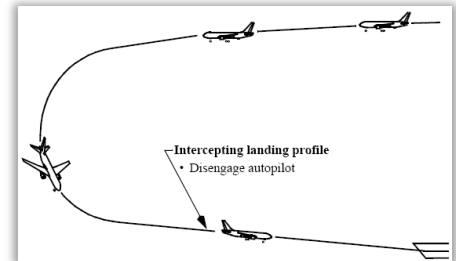

It should be noted that Boeing have been consulted on this issue and their response was adamant – the use of AP below MDA on NPA approaches is unacceptable. Reference is often made to the FCTM Circling Approach diagram that shows AP disconnect on final. Boeing’s response is that this diagram is based on a circling height of 400/500 ft and as such the annotated AP disconnect point is not applicable to our operation.

### 13.26. Manoeuvring below Minima – Visually

One of the more challenging manoeuvres in large aircraft is manoeuvring laterally and vertically after the minima – such as in a circling or side step landing. This can be particularly challenging in the simulator where visual references can be inadequate despite the high level of visual sophistication.

The nature of the 777 operation tends to limit the opportunities for hand flying, let alone manoeuvres such as circling and/or visual circuit approaches. As such there is a tendency to turn a visual manoeuvre into a numbers game, relying on information such as distance to run, height above the ground, VNAV path information, distance/tracking/path trend information from the ND, and more. A good pilot understands the strengths and weaknesses of the various sources of glass information during all stages of flight – but it is a common error of glass pilots during manoeuvres which are essentially visual to rely too heavily on the numbers and not enough (or at all) on the visual references associated with manoeuvring.

**Accurate data provided within the glass flight deck can provide a valuable cross check to a visual manoeuvre – but should not become the primary reference for flying the aircraft below the minima.**

The classic example of flight deck information backing up a visual flight manoeuvre is visual at the minima on a Cat I ILS Approach. While visual reference must be established with the approach lights in order to continue below minima (implying correctly that exterior visual reference is all that’s required) the ILS glideslope and localizer will typically provide accurate course information down to the runway, and should be used as a cross check of the visual picture. It can be a big ask for the PF to adopt quickly from the IMC to VMC environment (as well as flying manually) at the minima. The PF’s scan at the minima should retain a cross check of the GS and LLZ position and trend, with this component of the scan becoming less and the aircraft nears the runway and the visual references improve.

Another common example is manoeuvring during a circling or side step manoeuvre to a runway that is not active in the FMC. Placing the landing runway in the Fix page, along with a course line to emulate final approach and a three mile range ring (indicates approximate descent point for 3 degrees from the 1000 ft circling minima) can significantly improve situational awareness during the manoeuvre – but must not replace the use of visual references. If the landing runway is not active in the FMC, it is not available to the Fix page – however the Fix page will account for runway waypoints in Route 2.

### 13.27. Boeing Thrust Reference Setting Anomaly

There is a bug in the Thrust Reference setting software in the 777. While this bug manifests itself in several situations on normal and non-normal operations, it manifests significantly with flight safety implications during VNAV engine out approaches.

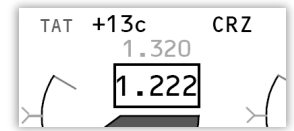

Boeing's airplane design is such that GA is set as the thrust limit (displayed above the N1 indication) any time the flaps are extended (FCOM 04.20.16 refers) or the glide slope is captured. One assumes that Boeing's intent was that GA should remain the thrust limit to either Landing or the Go-Around in order to provide maximum available thrust for manoeuvring while configured for landing.

However **when VNAV is engaged** after flaps have been extended, **the Thrust Limit is reset to CRZ**. In most normal operations this reduced thrust limit is adequate to preserve airspeed irrespective of configuration (Engine Out, Gear, Flap) – particularly in the 777-300ER. But 777's with less thrust such as the -300/-200, or in performance limiting situations such as weight in excess of MALW, high density altitudes, etc – insufficient thrust can exist to maintain airspeed/altitude.

Prior to a low speed excursion, stick shaker activation and AP stall protection, the problem can be corrected by :

- Selecting GA through the FMC Thrust Lim page;
- Pressing the CLB/CON switch (only CON thrust limit will be selected, not GA);
- Simply pushing the thrust levers forward (a disconnect for Manual Thrust is probably the better suggestion).

While CON thrust should be enough to maintain speed at maximum landing weight, higher weights may require even more thrust.

#### Scenario Description

Assume a 777 at maximum landing weight, approaching the final approach fix (FAF) at platform altitude for an Engine Out NPA. The crew intend to use VNAV for the approach, but have manoeuvred to the initial approach altitude using Basic Modes (FLCH / VS). Configured correctly at Flap 5/Flap 5 Speed, thrust reference will be either GA - or possibly CLB/CON if FLCH was used after Flap Extension. Any of these (GA/CON/CLB) should provide adequate thrust.

At 3 nm from the FAF, Gear Down/Flaps 20/Flap 20 speed is selected. Thrust levers retard to slow the aircraft to Flaps 20 speed. Meanwhile the PF will set the minima in the altitude select window on the MCP, check track, engage VNAV PATH and speed intervene.

However with the selection of VNAV, CRZ thrust reference is set – unnoticed by the crew. As the aircraft approaches Flap 20 speed, thrust levers advance in anticipation to achieve speed stability (giving the PF the tactile feedback expected of thrust maintaining speed), but thrust is now limited by CRZ thrust. Often Engine Out the combination of maximum landing weight and/or high density altitude, CRZ thrust is insufficient to maintain speed, but often enough to prevent a negative speed trend indication. Speed will now continue to reduce until (a) descent for the approach commences, (b) an increase thrust limit is set; or (c) stick shaker/stall protection.

Speed Protection? At minimum manoeuvring speed, low speed protection would normally kick in (minimum AFDS speed or eventually auto throttle wakeup), but in this case this protective feature is limited by the CRZ thrust limit setting. The only low speed protection (through the autopilot) that will function is stall protection - as the aircraft approaches stick shaker speed, it will pitch forward and descend with failed FMA AFDS mode indications.

Prior to a low speed excursion and stick shaker activation, the problem can be corrected by selecting GA through the FMC Thrust Lim page or pressing the CLB/CON switch (CON thrust limit only will be selected) – or simply pushing the thrust levers forward – whether disconnecting the A/THR first or not. CON thrust should be enough to maintain speed at maximum landing weight. Higher weights may require more thrust.

*Note that an additional trigger of flaps extending through 22.5° also sets GA thrust limit – so selection of Flap 25/30 resets the thrust limit. In all cases in the event of a TO/GA switch activation, GA thrust limit is set automatically irrespective of the setting prior to TO/GA switch activation.*

#### Additionally ...

- On all approaches (after flap selection), FLCH may set CLB/CON, but glide slope intercept will reset to TO/GA.
- TO/GA switch FMA mode activation sets GA thrust, so GA thrust limit is set during all go-arounds.
- Flap extension beyond 22.5° sets GA thrust limit.
- This anomaly does not impact on other NNM procedures (such as Windshear and GPWS). These recalls require either TO/GA Switch activation and/or manual thrust.

### 13.28. CDU VNAV DESC Waypoint/Alt – FPA/Bearing/VS information

The CDU Descent Page can provide useful vertical guidance when manoeuvring visually below minima, particularly to a runway that is not active in the FMC. While this is a visual manoeuvre and such information should not be used to replace pilot judgement (see **13.26 Manoeuvring below Minima – Visually**) – the vertical bearing and vertical speed information presented here can be used as valuable cross check **and indicates** the point at which a 3 degree descent should be initiated, particularly in the simulator when the PAPI's may not be clear.

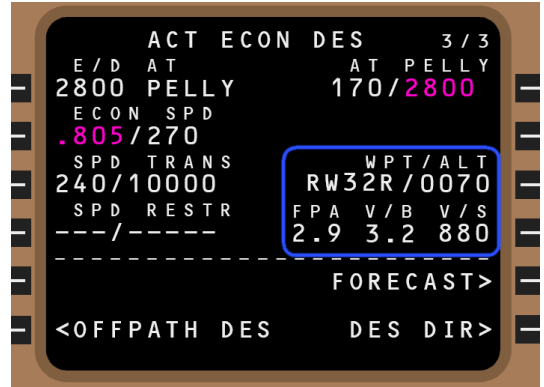

#### Overview

This section of the CDU Descent page operates independently of the rest of the FMC. It does not relate to VNAV Path calculations, it does not look at the route in the LEGS page (in fact the waypoint does not need to be in the LEGS page). Purely and simply, based on aircraft position/altitude, the Waypoint/Altitude in the WPT/ALT line (3R) – it provides:

- **FPA** : The aircraft's current Flight Path Angle (at or below level flight – no climb indications)
- **V/B** : The Vertical Bearing to the Waypoint/Altitude constraint in a direct line
- **V/S** : The VS required to maintain the Vertical Bearing requirement at current ground speed.

This information can be very useful as a means of increasing vertical situational awareness when the rest of the FMC is not providing useful information to the PF – specifically when manoeuvring away from the approach runway to the landing runway, such as during a sidestep manoeuvre.

The default waypoint chosen by the FMC is the next LEGS page waypoint with an altitude constraint – the waypoint cycles through as each waypoint/constraint is met.

#### Approach to a Side Step Landing

The Bearing/VS information can be particularly useful when transitioning from an approach on one runway to a landing on another in poor visibility. The aircraft transitions from an environment where a wealth of distance/altitude/profile information is provided to the PF, to an environment where even basic direct distance to the runway can be unavailable. While manoeuvring to final the Bearing/VS to the Landing Runway improves situational awareness with respect to the desired 3 degree approach slope. However while every waypoint in the ARINC database is available to enter into the WPT/ALT prompt – a runway that is not active in the LEGS page is not.

When the FMC is setup for an approach to one runway (eg: FAJS RW21R) but the landing will be on another runway (RW21L) the FMC **WPT/ALT** prompt will not accept the RW21L waypoint. However if the crew select the landing runway in the DEP/ARR page (eg: ILS Approach RW21L) **without executing the modification**, this inserts the waypoint into the LEGS page and therefore makes it available for use elsewhere (FIX, VNAV Off Path Desc, VNAV WPT/ALT) The runway waypoint can then be line selected into the scratchpad, the threshold crossing height added (eg: RW21L/5544) and the result inserted into the WPT/ALT field. The pending modification can then be erased – the waypoint and information will remain on the VNAV Descent **or Fix Pages as desired**.

### 13.29. LVOPS – the Last 50 ft

Being nearest the ground, the last fifty feet are crucial during LVOPS. Shortly after **"Fifty Feet"** the thrust levers begin to close (Right Hand) as the A/THR commands IDLE on the FMA. Shortly after **"Thirty Feet"** the AP commences the flare (Left Hand) as the AP commands FLARE (engaged) on the FMA. Shortly after **"Ten Feet"** ROLLOUT engages to ensure localiser centreline tracking.

While the CM1 can detect the first two changes through tactile feedback against the auto callouts, the CM2 is crucial to back up lack of mode engagements through the appropriate **"NO Idle/Flare/Rollout"** calls.

### 13.30. Visual Approaches

Visual approaches present some potentially unique challenges to the long haul operation. A combination of limited currency, minimal exposure to a destination and the significant fatigue levels encountered during the descent and approach phase often turn a manoeuvre the domestic pilot uses frequently as a significant time and fuel saver **into** a potential safety risk.

#### Don't abandon the Instrument Approach

Visual approaches are most often used at high density, multiple runway capital city airports to reduce the traffic separation requirement associated with an instrument approach. As long as visual traffic separation is adequate and maintainable, and visual reference can be maintained, acceptance of the visual approach is expected. However crew should not abandon the procedural nature of the instrument approach that was planned and briefed. While complying with the ATC visual approach requirement, crews should follow the instrument approach procedures, AFDS mode engagements, Standard Calls and Standard Procedures of the planned and briefed instrument approach to the landing runway. This includes maintaining the instrument approach minima settings and minima standard calls – setting 500 ft AGL in the MCP Altitude Selector when cleared for a visual approach is not a recommended technique.

#### AP/FD Use & Setting an Altitude – AAL+1000 ft.

When cleared for a (procedural) visual approach where a backup instrument procedure is not available, the pre-programming of the FMC to **provide** a 3° slope to the runway threshold/threshold crossing altitude can provide valuable LNAV/VNAV flight director guidance, even if only to a point where the aircraft is established on slope to the threshold. The use of AP during this manoeuvre is encouraged if it results in a lower workload **and** higher situational awareness for the PF/PM. V Australia Training recommend that the AP be disconnected after the aircraft is established on slope to the runway, **and must be disconnected by 1000 ft AAL.**

When the FMC is programmed correctly and AP/LNAV/VNAV is available for a visual procedural segment (eg: *Melbourne's SHEED to RW34*), in order to commence the visual descent a lower altitude must be set in the MCP. On an instrument approach this would be the intermediate altitude or minima – since there is no minima relevant to a visual approach, **1000ft AAL is set instead** (eg: *YMML 1400 ft*) to commence the descent. Once 300 feet below the initial altitude (and the Missed Approach Altitude) is achieved, the MAA should be set in the MCP. If the AP remains engaged the aircraft is at this point in an AP engaged open descent – crew must ensure that visual reference and terrain clearance is maintained to the runway. **For any visual procedure where the Flight Director does not provide valid guidance to the runway threshold, the AP must be disconnected and both flight directors should be switched off and the PM switched back on, by 1000 ft AAL.**

#### Which Missed Approach?

If an aircraft is cleared for a Visual Approach in Australia, then subsequently executes a go around, it is generally understood that irrespective of any previously assigned instrument approach procedure, a missed approach tracking straight ahead down the runway and climbing to 1500 ft AAL is expected. Internationally however, the situation is not so clear cut.

When a visual approach is offered and accepted from an instrument approach, generally best policy in the event of a go around is to follow the missed approach procedure of the originally assigned instrument approach. An additional complication is late runway changes – typically transitioning from an instrument approach off one runway to a visual approach on an adjacent one. What is to be the missed approach procedure? In practice ATC will normally provide immediate tracking guidance to an aircraft advising of a missed approach.

When in doubt – confirm with ATC the missed approach procedure required prior to having to execute it ...

#### In Summary

- Be wary of accepting Visual Approaches – ideally crew should brief for the possibility during the Arrival Briefing.
- If at all possible - continue the tracking, AFDS use, procedures and calls of the instrument approach when accepting a visual approach from a previously planned and briefed instrument approach.
- When the Visual Approach will be the primary procedure, prepare the FMC ahead of time to provide guidance and facilitate if possible the availability of LNAV/VNAV for the manoeuvre.
- AP use during a Visual Approach is encouraged – but not below 1000 ft AAL.
- **Set AAL+1000 ft in the MCP Alt Selector if a lower MCP altitude is required to initiate an AP/FD visual approach.**
- If the FD's will not provide guidance to the threshold, cycle both FD's off and the PM on by 1000 ft AAL.
- Ensure you have a clear understanding of the required missed approach procedure when accepting a clearance for a visual approach segment.



### 13.31. Late Runway Change

Airports with multiple parallel runways, particularly closely spaced parallel runways such as KLAX, present crew with the potential challenge of a late runway change.

It's worth noting that the difference between a runway change / runway side step / circling procedure is a blurred line. If changing the landing runway during an instrument approach is to be considered a circling approach – company A1 minima of 1000 ft AAL and 5000m visibility would be required.

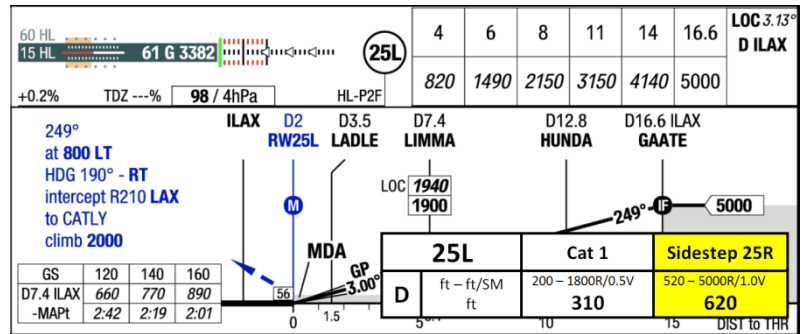

A late runway changes presents a few unique challenges to today's modern aircraft and is not a manoeuvre to be undertaken or accepted under impulse or without forethought – particular when ...

- Late runway change/sidestep has not been practiced in the simulator;
- Comes at the end of a ULH flight with a moderately fatigued (or worse) crew;
- Is not reviewed, practiced and encountered regularly;
- Has not been pre-briefed as part of the pre-descent Arrival Briefing.

Of these four points, a thoughtful and concise briefing is a big factor completely within the control of the operating crew. A late runway change presents the following issues that must be addressed during the Arrival Briefing:

- **Weather** – what minimum visual conditions will be acceptable to accept a runway change.
- **Altitude** – what is the latest point at which the crew will accept a runway change.
- **Stabilisation Criteria** – The A1 requires a stabilised approach by 1000 ft (500 ft visual circuit). Acceptance of a late runway change or sidestep procedure should result in the aircraft established within criteria by 500 ft AGL.
- **FMC Procedures** – Crew need to pre-determine what their actions will be with respect to Runway and Approach Selection in the FMC during the manoeuvre. Nothing done or not done in the FMC affects the aircraft's ability to land on a runway, but if the approach and runway is not selected, the published missed approach will not be available either – or worse, LNAV will engage and attempt to follow the wrong missed approach.

#### Missed Approach

Which missed approach will you fly? Which one do you have in the FMC? What do ATC expect? These questions should be discussed in the Arrival briefing and if necessary clarified with ATC. Typically if you're cleared to land on RW25R, you expect to fly the 25R ILS missed approach procedure. But part of the issue depends on when you agree to the runway change. It's entirely acceptable to be cleared for "ILS Approach 25L, cleared to land sidestep RW25R" based on the adjacent runway landing minima on the RW25L chart. In this case, based on the rules of manoeuvring for the runway after the instrument segment of an instrument approach – ATC would probably expect some form of the RW25L missed approach flown. **Or** would they?

249° **ILS 25L**  
at 800 LT  
HDG 190° - RT  
intercept R210 LAX  
to CATLY  
climb 2000

249° **ILS 25R**  
at 800 LT  
HDG 220° - RT  
intercept R210 LAX  
to CATLY  
climb 2000

### 13.32. ANP, RNP, Position and Position Accuracy

ANP/RNP is an often miss-understood concept. This section attempts to clarify the meaning of ANP/RNP as well as explain in detail the navigational performance scales (NPS) option installed on the V Australia 777 aircraft.

**RNP** : Required Navigation Performance attempts to move the focus away from specific navigational equipment (IRS, GPS, Radio/Nav, ILS, VOR, etc) and instead defines a standard of general use navigational accuracy. RNP10 (for example) is in common use in Oceanic Airspace – in this context, it means that an aircraft is required to be able to determine its position to within an accuracy of 10nm at least 95% of the time.

**FMC RNP** : It must be realised by crew that the FMC RNP values (which are displayed on the ND/PFD) are for the most part default values applicable to the phase of flight (takeoff, en-route, oceanic/remote, terminal, approach) and do not necessarily reflect the actual airspace requirement the crew find themselves in. Pacific Oceanic is typically RNP10 – the FMC however generally operates to RNP4 in cruise at high altitude. These defaults are selectable by the airline operator, and can be overridden by the crew in the FMC.

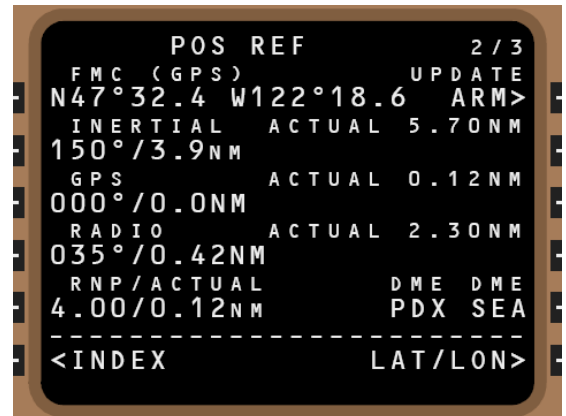

**ANP** : Actual Navigation Performance reflects the manufacturer guaranteed accuracy of the position determination mechanism of a navigation system. In the 777 there are three sources of geographical position determination – the GPS, the ADIRU and Radio/Nav position (as Radio Navigation is managed by the FMC). At any given time (when able to determine a position) each line will display the calculated ANP figure.

**FMC Position** : The FMC determines a separate position based on one (or all) of the three onboard positioning systems (GPS/IRS/NavRad). The FMC position is of prime relevance in actual aircraft operation - irrespective of the status of GPS/IRS/NavRad/ANP/RNP – the AFDS (through LNAV) follows the FMC position. The FMC position is the basis of the top of the triangular aircraft symbol on the ND Map, and the basis for the ND Map display itself. Typically the FMC will choose the navigation source with the lowest ANP as its prime determinant in calculating aircraft position (usually GPS) but it must be clearly understood that the FMC keeps its own track of aircraft position.

**RNP/ANP vs Position** : It's important to understand that RNP/ANP bear little relevance to the aircraft's actual position. RNP may be 0.3 and ANP may be 0.06 but that doesn't stop the aircraft being 1 mile left of track if incorrect crew procedures are used on approach. RNP/ANP is a measure of position determining accuracy – not a measure of how far from desired track the aircraft is.

**NAV UNABLE RNP** : Anytime the ANP exceeds the RNP, EICAS (after a short delay) will prompt with the NAV UNABLE RNP advisory/caution message. The relevance of this message needs to be clearly understood by the crew. In cruise over the Pacific (RNP10), this is likely to mean the GPS has failed, but since the FMC defaults to RNP4, it may not reflect a true loss of required navigational accuracy. The NAV UNABLE RNP message on final approach is a different issue altogether.

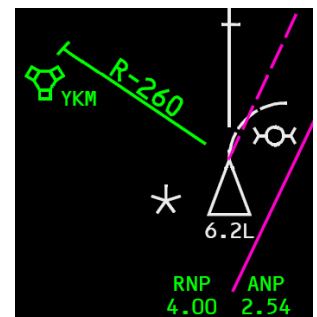

13.33. Navigational Performance Scales (NPS)

The navigational performance scales incorporate both an ANP/RNP scale and lateral track displacement display. Also included is a localiser displacement "Ghost Pointer" which displays when the ILS is tuned.

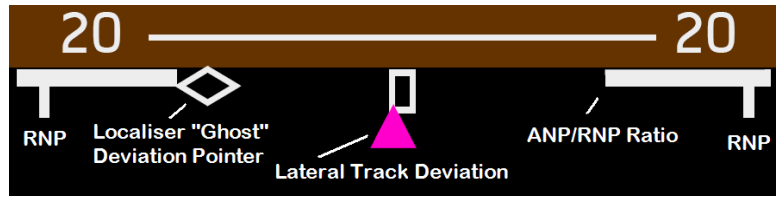

**ANP/RNP Scale** : This is the top part

(horizontal white band) of the NPS. The edge markers (small vertical white stripes at either end) reflect the RNP requirement. The horizontal white band grows with ANP growth as a percentage of RNP. Thus if the RNP is 4 and the ANP is 2, the horizontal white band will be 50% of its way from the edges towards the centre. When ANP exceeds RNP the band will be solid across the display, turn amber and flash briefly.

**Lateral Track Deviation** : The magenta triangle indicates track deviation as against FMC generated required track. It is a command instrument – pointer to the right indicates a requirement to turn right to regain track. The background scale of deviation is the current FMC RNP requirement. When lateral track deviation exceeds the ANP/RNP scale of the NPS (the RNP) the edge indications will turn amber and flash briefly.

**Ghost Pointer** : While typically thought of as the Localiser Pointer, this indicator actually "Represents the relative position of the path for the selected and activated approach". Got it? Think of it as the Localiser Pointer for now. The equivalent glideslope indication is available on vertical component of the NPS as well.

**Track Deviation / ANP-RNP Combination** : All this comes together in the NPS. The lateral NPS provides a linear representation of ANP/RNP percentage, indicating the degree of navigational accuracy inherent in the equipment being used to determine position. At the same time the lower NPS scale indicates the degree of track displacement being achieved by the crew. The combination of these two displays in the NPS indicates the navigational safety of the aircraft.



In the example pictured here, the aircraft is operating to RNP 1, experiencing ANP 0.5 (such as DME/DME updating) – so the RNP/ANP scale reflects a 50% reduction in available manoeuvring area on the NPS. At the same time the crew are off track by 0.7 miles – the aircraft is beyond the navigational tolerances of the approach.

13.34. Missed Approach Acceleration

ICAO PANS OPS (missed) approach construction specifies that member countries are to assess the missed approach flight paths for intermediate acceleration to a higher missed approach speed at an intermediate altitude (nominally 1000 ft). Unfortunately this has not been done in many cases. As such, to ensure terrain clearance in the missed approach when performance is marginal, the missed approach configuration and speed must be maintained to the nominated missed approach altitude, unless the aircraft is above a published MSA and can remain so.

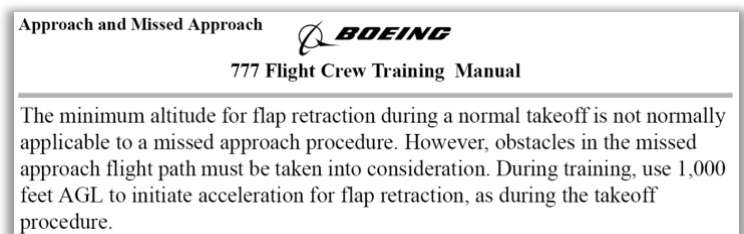

The Boeing FCTM encourages pilots to accelerate at 1000 ft during a missed approach "during training". However this technique is not applicable to single engine missed approaches, training or otherwise.

Because of the obvious issues associated with teaching two different missed approach techniques depending on whether All Engine or Engine Out, V Australia has elected to follow industry best practice and mandated acceleration at the published missed approach altitude, or when above MSA and terrain clearance assured – for all missed approaches.

13.35. Rejected Landing Procedure

A rejected landing is a manoeuvre performed when crew decide to action a go-around after the aircraft has touched down – reasons for this are few, but included in them would be a late landing with potentially insufficient runway to complete the landing roll safely.

Note that this could occur after speed brake deployment, but prior to reverse thrust application. **The application of the reversers commits the aircraft to the landing.**

V Australia has decided not to specifically implement a Rejected Landing procedure and instead **rely** on the documentation provided by Boeing in the FCTM. However the following points should be noted about the Boeing procedure.

- After touchdown, the TOGA switches will be inhibited – thrust application will be fully manual (maximum thrust should be used) and the flight directors will not give correct indications **until the TOGA switches are used airborne.**
- Be aware that the stabiliser trim may not be set correctly and control forces may unusual during rotation.
- Speed brakes will stow and auto brakes will deactivate when **the thrust levers** are advanced.
- A takeoff configuration warning will be generated as the thrust is advanced **with landing flap.**
- Rotation should be called by the PM once airspeed has reached the approach VREF bugged speed, or when 2000 ft of runway is remaining (600m, where the runway edge lights become amber on an ICAO LVP OPS compliant runway)
- Once airborne, the TOGA switches should be selected and the manoeuvre completed as a go-around through “Go-Around, Flaps 20” ... “Thrust / TOGA / TOGA” ... “Positive Rate” ... “Gear Up” as documented in the Boeing NPs.
- Crew are advised not to change flap selection on the runway as is the practice during pre-briefed touch and go landings.

Approach and Missed Approach **BOEING**  
777 Flight Crew Training Manual

**Go-Around after Touchdown**

If a go-around is initiated before touchdown and touchdown occurs, continue with normal go-around procedures. The F/D go-around mode will continue to provide go-around guidance commands throughout the maneuver.

If a go-around is initiated after touchdown but before thrust reverser selection, auto speedbrakes retract and autobrakes disarm as thrust levers are advanced. The F/D go-around mode will not be available until go-around is selected after becoming airborne.

Once reverse thrust is initiated following touchdown, a full stop landing must be made. If an engine stays in reverse, safe flight is not possible.

13.36. Missed Approach from Above MAA

KLAX has initial approach altitudes well above the missed approach altitude. As such in the event of a missed approach prior to the **MAA**, it's expected that crew will continue the approach descent towards the MAA as part of the missed approach manoeuvre. This presents a few interesting divergences from the standard go-around/missed approach manoeuvre.

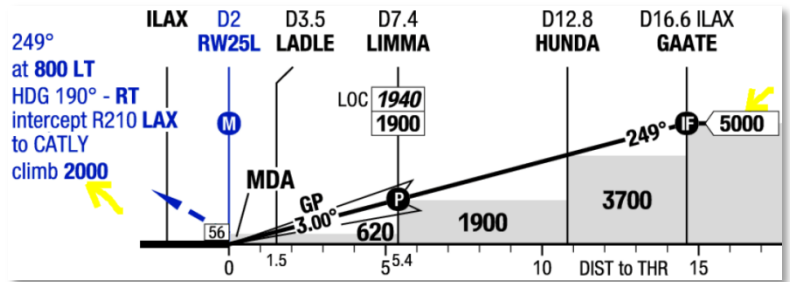

Firstly the TOGA switch is a no-no. You do not want a climb, you do not want go around thrust. This applies whether flying a Precision or Non Precision approach. Because of the variables involved (current altitude, current MCP selected altitude, current FMA, type of approach, etc) a single defined procedure may not apply. This is not a difficult manoeuvre, but it certainly benefits from a little thought and briefing prior to the approach to ensure both pilots are working from the same play book. How many times has that been said after a manoeuvre ...

Precision Approach		Non Precision Approach
<ul style="list-style-type: none"> <li>• Set MCP Altitude Selector to the MAA (2000 in example above)</li> </ul>		
<p><b>If APP is engaged (GS and LOC)</b></p>	<ul style="list-style-type: none"> <li>• De-Select APP mode.</li> <li>• AFDS FMA will revert to default Pitch and Roll Modes *</li> <li>• Select either LOC or LNAV to ensure accurate lateral tracking.</li> <li>• Use VS/FPA (Default Modes) to continue descent to MAA.</li> </ul>	
<ul style="list-style-type: none"> <li>• Once the AFDS has captured MAA, increase selected speed for the missed approach (250 Kts? Flaps Up Speed?)</li> <li>• PF can call “Go-Around, Flap 20” and a more conventional missed approach procedure can commence: “Positive Rate”, Gear Up, Flap Retraction, etc</li> </ul>		
<p>* Approach Mode de-select will only work above 1500 ft RA.</p> <p>* Default Roll Modes is TRK or HDG hold if Angle of Bank is ≤ 5° - otherwise ATT will be the engaged lateral mode.</p> <p>* Default Pitch Mode is VS or FPA.</p>		

### 13.37. Clean up, before trying again

There is a tendency in the simulator training environment after a missed approach to leave the aircraft at flaps five in anticipation of a short radar vector to final, minimising time and fuel expenditure. This is a simulator-training fixation that has no place on the line or in simulator LOFT line training.

After any missed approach at a major airport (where else is a 777 going to operate to?) the chances of being radar vectored a few miles after the missed approach, round to a 6 mile final at 1500 ft AGL are slim to none at best. In the case that this does happen, the chances of being in the right place at the right configuration and speed – with checklists complete, cabin and passengers updated, FMC setup complete, approach briefing updated as necessary **without error** is also pretty slim. Keeping flaps extended can also exposes the aircraft to prolonged flight in icing conditions with the flaps extended, which is less than ideal.

Instructor involvement (flight freeze, position freeze, repositions) notwithstanding – the best course of action is usually to clean the aircraft up completely, run the after takeoff checklist and prepare for a more successful second approach. Fuel notwithstanding of course ...

### 13.38. Reverse thrust before landing

There is a tendency during the flare for the PF to allow the thrust hand to move forwards to the reverse levers prior to the point at which the main wheels have touched down. This should be discouraged. Accidental lever actuation will not deploy the reversers until touchdown, but it does seem to cause reverser deployment to commence as soon as weight on wheels is signalled, along with Speedbrake deployment earlier than usual, with an associated “firm” landing.

### 13.39. Reverse thrust after landing

Thrust reverser lever movement should be commenced by the PF as soon as the main wheels are on the ground. There is no requirement to delay thrust reverse until the nose wheel has been lowered – indeed this only serves to increase landing distance.



## 14. After Landing

### 14.1. Autoland – Disconnect AP before A/Brake

During an Autoland, there is a potential threat to aircraft control if the Autobrake is disengaged and manual braking is commenced without AP disconnection. In this situation, the AP drives the rudder pedals to keep the aircraft on the centreline, while the pilot uses the rudder brake pedals to slow the aircraft.

In crosswinds if the aircraft begins to drift off the centerline, the AP will apply rudder to keep the aircraft straight. This will bring the drift side rudder pedal back towards the pilot, increasing braking on that side (as well as decreasing braking on the other) – exacerbating the runway drift – to which the AP will only increase the rudder application. Eventually this leads to either a runway excursion or an AP disconnect and sudden rudder input to the aircraft.

### 14.2. CM1 Speedbrake Lever Initiates After Landing Flow

The PM After Landing Flow (beginning with the consideration of APU start, ending in the EFIS CHKL button) should not commence until the CM1 has stowed the Speedbrake Lever after landing. Ideally this initiating action should not take place until the aircraft is clear of **all** active runways, and onwards taxi clearance has been received and briefed/discussed/understood between the two pilots. At this point, CM1 should stow the Speedbrake Lever and the PM After Landing flow can commence.

Note that if the aircraft clears the active runway and is then brought to a halt between runways, Speedbrake stowage and the After Landing flow can commence at the discretion and good judgement of the crew.

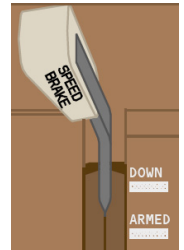

### 14.3. Towed Onto Stand

Some parking stand environments do not permit the crew to **taxi** the aircraft into position. The aircraft is marshalled to a position short of the stand - whether clear of the parking environment or just short of the correct parking position.

Once marshalled to the initial stopping point, the parking brake should be set and assuming the APU is available, the engines shut down. It should be noted that if there is any doubt about the ability of the tug to shift the aircraft (such as uneven tarmacs with a history of problems in this area) then the engines may need to be left running – the C1 will refer.

The seat belt signs should remain on, the passengers seated and the shutdown flow delayed until the parking brake is set after the aircraft comes to rest on stand. If not already done, don't forget to advise the cabin crew to disarm doors and cross check during the **tow** into stand.

Some Captains may choose to advise the passengers of this procedure during the descent PA; or an alternative is a quick PA from **CM2/CM3/CM4** as the aircraft initially comes to a halt **to** ensure the passengers **obey** the seat belt signs and remain seated.

### 14.4. Parking Brake & The Shutdown Checklist

The intent of the SOPs is that the Parking Brake will be released shortly after shut down, once the ground engineer has confirmed chocks are in place. CM1 will release the parking brake ensuring the aircraft doesn't roll – after potentially considering the slope and slickness of the ramp. Then the cabin doors will be opened. It's worth noting that releasing the parking brake during passenger deplaning can potentially result in aircraft movement that may have an unforeseen negative result – although there is no specific limitation on doing so.

However sometimes you never get the magic phrase from the engineer and you're left hanging with the Parking Brake Set. The issue here is that you must subsequently ensure that chocks are in fact in place and release the Parking Brake – or obtain a positive aircraft handover to engineering, advising them the Parking Brake is still set. Otherwise residual hydraulic pressure will be bled away by the Parking Brake until the accumulator is emptied, at which point the aircraft could roll away ...

Typically the Shutdown Checklist is then completed with "Set" as the response to the Parking Brake. An alternative to this is to hold the Shutdown Checklist until positive confirmation is received of chocks in place, Parking Brake Released.

### 14.5. OFP Completion Post Flight

Completion of the OFP as a Flight Log is both a CAR and A1 requirement. The Landing (On 22:46) and On Blocks (In 23:01) time values are completed after the aircraft generates an In event (fuel controls in cutoff; parking brake set; first cabin door opened). The fuel block should also be completed with Arrival Fuel and Fuel Used entered.

ETA	2251	BLK	FLT
ARR	0030	2301	2246
DEP	1000	0958	1014
ET	1400	13:03	12:32

FUEL RQD	14.12	118802	118.6
EXTRA		0	0.0
RAMP FUEL		118802	118.6
FUEL REMNG	01.35	13020	14.5
FUEL USED		105782	104.6

## 15. Diversions

### 15.1. General

This section incorporates some common sense, practical points on the area of diversions. Because of the varied natures of an in flight (or end of flight) diversion, crew need to use common sense and airmanship in all aspects of diversion planning and execution.

### 15.2. Extra Documentation

V Australia contract ground handling support outside of our usual area of operation to Universal Aviation (<http://australia.UniversalAviation.aero/>) and part of this provision of service is the provision of an International Port Diversion Manual. This manual is available on the aircraft laptops at `VA_Manuals\Flight Operations\Reference Documents\Misc References\Diversion Port Manual.PDF`

This document includes a host of detail on contact phone numbers (for everyone), parking information, hotels, refuelling, engineering, transportation, customs/immigration, catering, 777 services available, etc.

### 15.3. Parking – Nose In?

One common issue in a diversion is accepting a nose in stand, or any other stand that precludes the ability of the aircraft to depart the apron without assistance, without first ensuring a 777 rated push back tug is available. Because of the potential high weight of the 777, **tug** availability can be limited in airports that don't usually handle the aircraft. It's worth noting that even when the departure weight will be significantly reduced (such as recovery after a diversion at destination) a tug that can push a 767 at maximum weight may not be available to push the 777 at a lesser weight, particularly in first world countries.

### 15.4. ADIRU & SATCOM

Sometimes, the SATCOM can be your best friend during a diversion, enabling instant contact across the world to Operations, and across the airport to the ground staff, refueller, ATC or engineering. SATCOM depends on the ADIRU, so consider leaving the ADIRU on until you're sure you don't require SATCOM.

## 16. Document Change History

Date	Author	Paragraphs Affected	Change Descriptions	Ver
24.Aug.08	KP	All	Initial Issue	1.0.1
15.Aug.08	KP, MM	3.7 : Altitude Selector and Engine Out Drift Down Descents	Inclusion of Altitude Selector usage on Engine Out Drift Down Descents.	1.0.2
		2.7 : Two heads down – in general 3.6 : Keep pressing that Altitude Selector ... NOT 4 : Flight Management Computer 4.8 : The FMC is trying to tell you something – why aren't you listening? 5.3 : Slow down, enjoy the emergency 5.4 : Confirming Memory Items/Checklist actions 5.10 : Wake up the PM 5.13 : ECL checklist Title usage 5.16 : Dual Engine Fail/Stall – who flies? 8.5 : Pre-flight : Keep the EICAS Clear 8.6 : Starting the APU – Start, Release to ON 9.9 : Clear to disconnect after Recall	Corrections & Clarifications.	
		12.15 : Setting up for Approach – PF or PM?	Added comment on FMC Setup during Holding, and requirement for positive crosscheck of the FMC by the other pilot.	
17.Aug.08	PH, KP	2.9 : Altitude Selector 1000 vs Auto	New Paragraph.	1.0.3
		4.6 : Route Discontinuities are our Friend	Additional summary comment on Route Discontinuities.	
		4.3 : Hold Page when Holding	New Paragraph.	
		13.12 : "Are you ready for the approach?"	Added a comment about holding above IAF altitude.	
20.Aug.08	KP	Initial Issue to Crew – All highlighting removed.		1.0.4
30.Aug.08	KP	1.2 : Is this a procedural document – do I have to follow it?	Updated Boeing documentation references.	1.0.5
		2.3 : Checking the next checklist	Reworded	
		5.3 : Slow down, enjoy the emergency	Reworded	
		5.14 : Flaps for Go-Around	Added to cover the common error of Flaps 5 after all Flaps 20 approaches	

Date	Author	Paragraphs Affected	Change Descriptions	Ver
08.May.09	KP	All	Replaced the concept of Checklist Recalls with Checklist Memory Items.	1.0.6
		Front Matter, 1.1 : Why a Practices and Techniques document?	IAW Apr09 Training Meeting, Common Errors is renamed Practices and Techniques.	
		2.5 : PF does the Rudder Trim 2.6 : Glass Cockpit Scan	Added a reference to 7.6 EFATO – Trimming Added example of an inappropriate map scale.	
		2.8 : Altimeter Subscale Setting 2.10 : Supplementary Procedures	Added a reference to the requirement cross check subscale only (8.8 Pre-Flight Checklist – Altimeters) Discussion of FCOM Supplementary Procedures	
		3.4 : Heading Select THEN Select Heading 3.6 : Keep pressing that Altitude Selector ... NOT	Added a comment regarding keeping the Heading bug in synch Turns out there's (at least) a fourth reason to press the Alt Selector ...	
		3.7 : Altitude Selector and Engine Out Drift Down Descents 3.9 : Before you engage that mode ... 1.1 : VS : (Not So) Very Special Mode	Minor Corrections Discussing the use of VS and FPA.	
		3.11 : Flight Level Change and SPEEDBRAKE EXTENDED	Discusses the impact of smaller level change with FLCH that result in an intermediate thrust setting – and subsequent speed brake use.	
		4.4 : Navaid : To AutoTune or Not AutoTune ... 4.7 : ALTN Page – DIVERT NOW	Discussion on Navaid AutoTune and Manual Tuning. Discusses the common error of deleting the required Hold or Active Waypoint when using Divert Now	
		5.1 : Checklists and Checklist Memory Items you've never seen 5.4 : Recall/Checklist Item confirmation and Area of Responsibility on the ground 5.5 : How to guard a control 5.7 : Oxygen Masks	Clarified the items recommended for memorisation. Deleted – New Section 6. Non Normals on the Ground Added a comment that control guarding is not mandatory in V Added a comment on prescription glasses and oxygen masks	
		5.15 : Communication after a NNM – who do you call? 5.17 : Flaps/Slat problems & Speed Reduction 5.19 : Landing using Flaps 20 Yes/No	Updated to include the ACARS Diversion report. Added to cover delaying speed reduction during Flap/Slat abnormalities. FMC Flap/Speed should not be set until specific instructions are given by the NNM checklist.	
		5.21 : Slats Drive – Do We Extend the Flaps? 5.22 : Memory Items Complete ... 5.25 : Rapid Descent and Task Protection 5.28 : Cabin Altitude Checklist (Silently)	Added to identify the potential confusion associated with extension of Slats during Flaps Drive Failure (and the reverse). Emphasises the need for "... Recalls Complete" Amended to reflect the likelihood of the NNM checklist having to wait until the aircraft has recovered at 10,000 ft. Added to discuss the issue of the PM running the Cabin Altitude checklist silently after completing the Recall during a Rapid Descent.	
		6 : Non Normals on the Ground 6.2 : Confirmation is not required 6.3 : To Stop or Not to Stop ... 6.6 : If you're going to Stop 6.5 : Passenger Evacuation & Paper QRH Usage 6.4 : Engine In flight Re-Starts – Damaged Engines (Deleted) 6.7 : Passenger Evacuation & Clearing the Runway 6.9 : Rejected Take Off – Give the CM1 a Chance 7.1 : Engine Failure After Takeoff (EFATO) – Pitch Attitude 7.6 : EFATO – Trimming 7.13 : Engine Failure Analysis 7.4 : Non Standard Engine Out Altitude (Deleted) 7.14 : Engine In flight Re-Starts – Damaged Engines	New Section Confirmation of Memory and Checklist Items is not required on the ground. CM1 is advised to take control and stop the aircraft for certain non normals. Running NNMs on the ground the Boeing way. Tony Dodd's technique for using the QRH during Pax Evac. Moved to Section 7 Engine Failure After Takeoff (EFATO) Brief discussion of clearing the runway prior to a Pax Evac, or after a rejected takeoff. CM2 needs to be careful distracting CM1 during an RTO prior to the completion of the stopping manoeuvre. Added to cover the issues associated with pitch attitude after an engine failure on takeoff. Discussion of using the PM to trim the rudder during EFATO. Discusses the Boeing method of diagnosing the need for Checklist Memory Items immediately after takeoff. Removed – This section has been replaced by 8.20 : Noise Abatement - FMC TAKEOFF REF P2/2 Discussion of engine parameters & contemplating an engine in flight re-light.	

Date	Author	Paragraphs Affected	Change Descriptions	Ver
08.May.09	KP	7.5 : Centre Tank Fuel (Deleted)	Removed – Boeing SOP now requires the CTK Pumps On when at least 4.8 tons in the centre tank (not to wait for FUEL IN CENTRE message)	1.0.6
		7.15 : CLB/CON Thrust during EFATO Acceleration	Discussion of engine parameters & contemplating an engine in flight re-light.	
		7.12 : Engine Fire on Takeoff – Early Acceleration & Climb Thrust	Discusses issues associated with Engine Fire on Takeoff – early acceleration, use of FLCH, Climb Thrust, Recalls and Checklist.	
		7.2 : Engine Out, High Weight, High Altitude, Turning	Discussed the issues with turning during acceleration and high weight/high altitude.	
		8.2 : Pre-Flight Briefing – Expediting	Discusses the minimum requirements for a pre-flight document briefing and some techniques for expediting NOTAMS and Weather	
		8.11 : Revising the Standby Fuel Figure (NOT)	Un-necessary revisions of the Standby Fuel to the Refueller increase workload and the opportunity for error in the refuelling process.	
		8.16 : FMC Reserve Figure	Clarifies the figure to be used in FMC RESERVES pre-flight.	
		8.20 : Noise Abatement - FMC TAKEOFF REF P2/2	Discusses the TKOFF REF P2/2 and the values applicable to Company Standard/Noise Abatement/Non Standard Engine Out Altitude.	
		8.21 : FMC vs CFP Lat/Lon Waypoints and Positions	New paragraph to describe the procedure for verifying Lat/Lon waypoints between the FMC and CFP. Amended for clarity.	
		8.23 : FMC Initialisation with ACARS Uplink	New procedure for ACARS initialisation via Datalink	
		8.24 : Use of OFP RAMP and LNDG fuel correction figures	Discussion of the use of OFP RAMP and LNDG fuel correction figures during pre-flight.	
		8.26 : Final ZFW – What do we do with that?	Details the cross check procedure advised when the Final ZFW is provided to the crew; explains usage of the OFP Dispatch Message.	
		8.28 : Load Sheet Arrives – OFP Dispatch Message page	What to write on the Dispatch Message when the Load Sheet arrives.	
		9.6 : Fuel Control Switch to RUN During Start	There is no requirement to wait for engine parameters prior to selecting the Fuel Control Switch to Run during Engine Start.	
		9.2 : Pushback Sequence	Altered to improve clarity.	
		9.12 : Anti-ice and the Before Taxi Checklist	Amended to change “After Start” to “Before Taxi” Checklist.	
		10.4 : Thrust Usage on the Ground	Notes on the use of excess thrust on the ground.	
		11.1 : HDG/TRK Select (and HOLD) for takeoff	Discourages the use of Hdg/Trk Sel/Hold for takeoff.	
		11.7 : Increasing VR for Strong Crosswind Conditions / Windshear	Reviews the FCTM technique for increasing VR in the event of string crosswinds.	
		11.8 : Flap Retraction & Extension	Updated comments on Flap Extension / Retraction. Added comment on 744 & 737 aspects of flap extension.	
		11.10 : VNAV Path after Take Off?	New paragraph to discuss engagement of VNAV PATH after takeoff and subsequent failure to accelerate.	
		12.1 : Filling in a Flight Plan	Recommendations	
		12.2 : EDTO Critical Fuel Check	Discusses the need to monitor excess fuel at most critical EDTO ETP.	
		12.6 : Updating FMC Winds	Discusses the option of updating the FMC winds in flight.	
		12.20 : FLCH Descent at 240 Knots	VNAV commands 240 knots on descent – FLCH doesn't have to.	
		12.23 : When do you do the Recall and Notes?	The Recall/Notes items should be done prior to calling for the Descent Checklist.	
		13.1 : VNAV Approach Validation	Addition to discuss the validation of the FMC VNAV Approach Added RNP values for GPS/VOR/NDB as part of VNAV Approach Validation check.	
		13.2 : VNAV Approach – No Path Indicator	Discusses the need for the VNAV Path Deviation Indicator, and how to get it back if it's missing.	
		13.5 : VNAV Approach – Early Descent	Discusses missing waypoints, VNAV early descent and highlights the importance of VNAV Approach Validation & Briefing.	
		13.3 : Alternate MCP Altitude Setting Technique	Addition to discuss the requirement to set intermediate approach altitudes when using VNAV.	
		13.6 : VNAV Approach – Speed Jumps Up	Discussion of the speed jumping phenomenon at the commencement of VNAV NPAs.	
		13.8 : FLCH during NPA's	Discusses the crew tendency to revert to FLCH when high on NPA's.	
		13.7 : MDA or MDA+50?	Discussed MDA/MDA+50 and hybrid approaches such as sidestep to adjacent runway.	
		13.4 : Setting DH/MDA for Cat IIIB No DH Approaches	Clarifies setting the MDA/DH Selector when conducting No DH Autoland Approaches.	
		13.11 : VNAV ALT on Approach	Discusses VNAV ALT on approach, causes and fixes.	
		13.14 : LNAV into Localiser Capture	Reviews the dangers and benefits of using LNAV to capture the localiser.	



Date	Author	Paragraphs Affected	Change Descriptions	Ver
08.May.09	KP	13.16 : Arming Approach Mode	Identifies some common good habits with respect to arming the APP mode, as well as the need to forsake these when circumstances dictate.	1.0.6
		13.17 : Glideslope Intercept From Above	Discusses a technique for intercepting the ILS glideslope from above.	
		13.18 : Circling Minima	A1 circling minima is often higher than LIDO requirements.	
		13.22 : Flt Director OFF at Minima?	Review of the recommendation to switch off both flight directors after the minima on NPA's.	
		13.23 : Unnecessary Actions during Circling Approaches	Un-necessary actions during the visual manoeuvring segment of circling approaches should be avoided.	
		13.25 : Circling Approach : Descent from MDA using AP	Reviews use of VS to descend below Circling MDA.	
		13.26 : Manoeuvring below Minima – Visually	Discusses the common mistake of over reliance on glass instrument indications below minima.	
		13.28 : CDU VNAV DESC Waypoint/Alt – FPA/Bearing/VS information	Discusses the uses of the FMC CDU VNAV Descent page FPA/VB/VS information.	
		13.31 : Late Runway Change	Discusses the issues associated with late runway changes. Added comment regarding A1 circling minima.	
		13.29 : LVOPS – the Last 50 ft	Discusses the critical nature of the last fifty feet during LVOPS	
		13.32 : ANP, RNP, Position and Position Accuracy	Discusses terms and definitions associated with ANR/RNP operations	
		13.33 : Navigational Performance Scales	Details the 777 NPS	
		13.34 : Missed Approach Acceleration	Removed the word “acceleration” from “missed approach acceleration altitude”	
		13.36 : Missed Approach from Above MAA	Some basic guidance for this manoeuvre, common at KLAX.	
		14.2 : CM1 Speedbrake Lever Initiates After Landing Flow	New paragraph to discuss best practice w.r.t after landing flow commencement.	
		14.3 : Towed Onto Stand	Suggested procedure with being towed onto stand.	
		14.4 : Parking Brake & The Shutdown Checklist	Issues associated with not receiving confirmation of chocks in place.	
		15 : Diversions	New Section	
15.1 : General	Section Description			
15.2 : Extra Documentation	Additional documentation on diversion airports			
15.3 : Parking – Nose In?	Beware of stands at diversion airports			
15.4 : ADIRU & SATCOM	Remember ADIRU is required for SATCOM			

Date	Author	Paragraphs Affected	Change Descriptions	Ver
09.Feb.10	KP	Various	Replaced EFIS Review with Takeoff Review Replaced use of the word "Guide" with "Amplification" (CASA)	1.0.7
		1.3 : Checklist and Checklist Memory Items	Details how Boeings change from " ___ Recalls" to " ___ Memory Items" is dealt with in this document.	
		2.8 : Altimeter Subscale Setting	Added a note on the susceptibility of RNAV approaches to poor altimetry procedures.	
		1.1 : VS : (Not So) Very Special Mode	Update for use of VS/FPA at high alt in IAS instead of MACH.	
		5.9 : NNM Checklists Complete ... EICAS Recall vs Review	Crew are commonly performing an un-necessary EICAS Recall after NNM's.	
		5.23 : Fuel Jettison, Fuel To Remain – How Much?	Discusses the decision of Fuel To Remain on the Fuel Jettison Checklist.	
		5.29 : Fuel Jettison & Fuel Imbalance	Discussion of the issues associated with Fuel Jettison and a subsequent Fuel Imbalance requirement. Transferred from EICAS/ECL Document.	
		6.1 : Keep the Big Picture	Remember the world around during NNM's on the ground. Transferred from EICAS/ECL document.	
		6.4 : Who has the Radio?	Discusses the potential of CM1 taking the radio for critical NNM's.	
		6.6 : If you're going to Stop	Removed comment on the previous method of NNM handling on ground during critical emergencies. Nobody cares.	
		6.8 : Landing NNM's & Passenger Evacuation	Transferred from EICAS/ECL document.	
		7.6 : EFATO – Trimming	Added a suggested technique for the first 400 ft of EFATO	
		7.7 : In Flight Engine Start	Transferred from EICAS/ECL document.	
		7.8 : Thrust Lever Usage while Engine Out	Questions asked about using the Thrust Lever of the failed engine.	
		8.4 : EICAS Recall during Pre-Flight	Details the best method of clearing the EICAS during pre-flight while also checking for previous engine exceedences.	
		8.9 : Seating – Eye Position	Discusses Seating Position on the flight deck	
		8.17 : ILS Tuning for Departure	Discusses the issue of ILS Tuning for Departure	
		8.20 : Noise Abatement - FMC TAKEOFF REF P2/2	Revised as the result of Oct09 Training Meeting. Clarified NADP1/2 inconsistencies.	
		8.25 : Uplinked Winds	Details the wind uplink anomaly when 5 levels are flight planned.	
		8.15 : ACARS OPT Check – Get what you Need, not what you Wanted	NTC requires crew to check the OPT result against the settings requested. A more valid check is the OPT result against the conditions about to be tested with a real live takeoff.	
		8.27 : Aircraft DOW & DOI	Clarification of the A1 requirement to cross check DOW/DOI on the load sheet.	
		8.30 : Pre-Start Hydraulic Pressurisation	Clarification of the Pre-Start Hydraulic Panel Flow.	
		9.10 : Engine Anti-Ice ON after start	Updated the definition of Icing Conditions on the Ground.	
		10.5 : Carbon Brakes – Operating Differences	Brief discussion of the operational impact of Carbon Brakes	
		10.6 : Returning to Stand	New section dealing with Return to Stand during Taxi Out.	
		11.6 : Thrust Handover	Transferred from EICAS/ECL document, summary added.	
		12.2 : EDTO Critical Fuel Check	Reviews the implications of Critical EDTO fuel and the requirement to monitor in flight.	
		12.7 : EDTO Plotting Chart	New section expanding on the A1 plotting requirement.	
		12.5 : Block Clearances	New section detailing some issues with Block Clearances	
		12.10 : Crew Handover Briefing	New section discussing Relief Crew Handover briefing.	
		12.14 : Big Font, Little Font – the VOR/DME Ident	New section dealing with VOR/DME Ident Anomaly.	
		12.19 : No Published Transition Level	Discussed the threat associated with airports without a published transition level.	
		13.2 : VNAV Approach – No Path Indicator	Updated for the risk associated with setting cruise altitude to force the FMC into Descent Mode.	
		13.10 : Extending the Centerline	Discusses a suggested use of the DEP ARR centreline extension feature.	
		13.15 : Localiser Approaches – FMC Selection	Crew should look for a Localizer specific approach in the FMC before selecting the ILS approach.	
		13.20 : ILS Approach to Circle	Updated.	
		13.24 : "Localizer" vs "Localizer Capture" (... and Glideslope ...)	Added to clarify confusion between FMA Localiser/Glideslope Capture call and the associated deviation calls.	
		13.30 : Visual Approaches	New section dealing with Visual Approaches	
		13.35 : Rejected Landing Procedure	Transferred from EICAS/ECL document.	
		14.1 : Autoland – Disconnect AP before A/Brake	Warns about potential risks associated with disconnecting A/Brake during Autoland without disconnecting the AP.	

Date	Author	Paragraphs Affected	Change Descriptions	Ver
11.Apr.10	KP	2.1 : Recall during Flows	Re-worded for clarity.	1.0.8
		4.1 : FMC Changes : "Confirm" ... "Execute"	Added a tip regarding using PLAN mode to confirm direct to FMC modifications (thanks to Capt Origami)	
		7.9 : Engine Out – When do we Accelerate?	Introduced to clarify that engine out acceleration usually takes irrespective of any engine out manoeuvring.	
		8.3 : Aircraft Power Up	Added a paragraph concerning incorrectly performed power ups.	
		8.27 : Aircraft DOW & DOI	Amendment for new FODS format.	
		8.10 : Defuelling	Notes some personal history with Defuelling.	
		8.22 : FMC Track/Distance Checking – Oceanic, Lat-Lon, Off Airway Waypoints	Revised to remove the requirement to verify all Oceanic Track/Distances – only Lat/Lon and Oceanic Off Airway tracking.	
		8.23 : FMC Initialisation with ACARS Uplink	Updated to remove reference to 2000 ft step.	
		9.2 : Pushback Sequence	Added a note as to why we pressurise after ATC push clearance.	
		9.3 : "Cleared to Pressurise?"	Clarifying the automatic commencement of the Before Start Flow by the CM2 once ATC Start Clearance has been received.	
		10.7 : Taxi Technique – General Tips	Section to highlight taxi deficiencies identified during line operations.	
		12.3 : EDTO Critical Fuel – Do We Need It?	Once dispatched, EDTO Critical Fuel is not required, although less than minimum fuel at the ETP should be reported.	
		12.6 : Updating FMC Winds	Updates this paragraph to describe how request specific winds.	
		12.5 : Block Clearances	Updated to reflect the issues associated with VS at higher altitudes, and the preference of VNAV to change levels	
		12.4 : Use of VS to change Level at Higher Altitudes	Added IAW TM 2010.03.25. Refers to 12.5 Block Clearances where the issue of VS at high altitude is directly relevant.	
		12.9 : Step Climbs – OFP vs FMC (Optimum vs Recommended vs STEP)	Reviews and summarises the information on step climbs available in the FCOM/FCTM.	
		12.10 : Crew Handover Briefing	Updated for details of A1 limits on Crew Handover.	
		12.21 : Setting Vref Early	Discusses setting Vref early and the associated issues.	
		12.11 : Totalizer vs Calculated Fuel	A discussion about Calculated vs Totalizer Fuel	
		12.12 : HF Radio Usage	Suggested setup for HF L/R - Primary/Secondary usage.	
13.9 : Modifying an Existing Hold	Notes the inability to modify a hold once commenced.			
13.30 : Visual Approaches	Updated to highlight the recommendation to maintain instrument approach minima settings and calls when cleared for a visual approach off an instrument approach.			
14.5 : OFP Completion Post Flight	Paragraph moved from Section 12. Emphasis placed on completion requirement IAW TM 2010.03.25			

Date	Author	Paragraphs Affected	Change Descriptions	Ver
23.Feb.11	KP	Various	Minor spelling, grammar changes, duplicate word removal, paragraph re-ordering, etc. Highlighted in relevant sections.	1.9
		3.2 : Don't throw the aircraft at the Autopilot	Added common error examples of the behaviour	
		3.7 : Altitude Selector and Engine Out Drift Down Descents	Update picture for QRH amendment. Added another possible reason for pressing the Alt Selector.	
		4.1 : FMC Changes : "Confirm" ... "Execute"	Added a caution to check distance when checking direct to's.	
		4.8 : The FMC is trying to tell you something – why aren't you listening?	Added some specific examples of commonly ignored FMC messages, the associated meaning and likely impact.	
		5.14 : Flaps for Go-Around	Added a note regarding Flap 20 remaining for go around.	
		5.18 : Flaps/Slat problems & Slower Deployment	Brief description of the time/distance impact of secondary extension.	
		5.19 : Landing using Flaps 20 Yes/No	Corrected image (what was I thinking before?)	
		5.20 : Setting a NNM Vref – reference the ECL Notes	Don't set/update NNM vref's from memory – use the ECL/QRH Notes.	
		5.21 : Slats Drive – Do We Extend the Flaps?	Re-worded to focus on the Slats Drive failure after an amendment to the Boeing QRH.	
		5.24 : Overriding NM Checklist Items.	Discusses the need to verify first items on the NM checklist that require Item Override in order to complete after a NNM.	
		5.25 : Rapid Descent and Task Protection	Amended to leave the option of running the checklist in exceptional circumstances – such as slow depress, the simulator, etc. Updated for changes in AIRCRAFT checklist (one day the sim will match ...)	
		5.26 : Dispatch with a NNM	Discusses appropriate use of NNM checklists when dispatching with a NNM.	
		5.27 : Fire Engine – Use Your Own Clock	The use of the ECL to time 30 seconds between fire bottles is not recommended.	
		6.5 : Passenger Evacuation & Paper QRH Usage	Update picture for revised QRH.	
		6.6 : If you're going to Stop	Updated text for revised QRH Evacuation Checklist.	
		7.3 : TO2 ... Engine Failure ... TOGA ... Vmc A/G?	Discussed the implications of applying TOGA thrust with fixed derate takeoff speed calculations are in use.	
		7.4 : AICC – Announce, Identify, Confirm, Commence	Introduces the AICC model for engine malfunction handling, particularly at low altitude during takeoff.	
		7.5 : Fly The Aircraft – What does it mean?	Discusses the concept of Fly The Aircraft as it relates to EFATO.	
		7.6 : EFATO – Trimming	Added a comment on home brew trimming techniques.	
		7.10 : Acceleration, Configuration and Memory Items	Discussed the issues of engine out acceleration coincident with running checklist memory items.	
		7.11 : Engine Failure Handling – a Paradigm Shift	Discusses the paradigm shift in the QRH engine malfunction handling and the implications.	
		7.12 : Engine Fire on Takeoff – Early Acceleration & Climb Thrust	Amended for clarification	
		7.13 : Engine Failure Analysis	Section completely re-written in a further attempt at clarity.	
		7.14 : Engine In flight Re-Starts – Damaged Engines	Updated picture for QRH amendment. Text update for QRH changes.	
		7.15 : CLB/CON Thrust during EFATO Acceleration	Amended for clarity.	
		7.16 : Engine Out Procedures – AIT	Clarifies that AIT refers to the first turn on the all engine SID.	
		7.17 : Engine Failure on Takeoff – Overview Diagram	Overview diagram depicting a suggested EFATO handling flow.	
		8.1 : Pre-Flight Briefing – Management	Added a discussion of the implications of delegated pre-flight briefing tasks.	
		8.2 : Pre-Flight Briefing – Expediting	Moved.	
		8.12 : OPT and Takeoff Performance – Lessons from the Industry	Discussed the findings in the ATSB Takeoff Performance Data Entry error report as they relate to our operation.	
		8.13 : OPT Usage – A Practical Application	Suggests a practical method for implementing OPT in the flight deck.	
		8.14 : OPT Independent Cross Check – The Next Level	Discusses the importance of the independent cross check and suggests how this concept should be extended to the data the OPT calculation is based on.	
		8.16 : FMC Reserve Figure	Clarified.	
8.18 : Application of CDL Performance Limits	Discussion on the application of CDL performance penalties and OPT use on takeoff and landing.			
8.19 : Re-Clearance Flight Plans & Final ZFW	Notes on re-clearance procedures and the importance of recovering full contingency if possible.			

Date	Author	Paragraphs Affected	Change Descriptions	Ver
23.Feb.11	KP	8.20 : Noise Abatement - FMC TAKEOFF REF P2/2	Revised to improve clarity and compliance. Images removed, table specifying values inserted.	1.9
		8.21 : FMC vs CFP Lat/Lon Waypoints and Positions	Clarification of the requirement for both crew to independently verify the FMC route against OFP	
		8.22 : FMC Track/Distance Checking – Oceanic, Lat-Lon, Off Airway Waypoints	Clarification that both crew may work together to verify track/distances – independent verification not required.	
		8.23 : FMC Initialisation with ACARS Uplink	Added a note about expediting uplinks in order to avoid wind uplink buffer overruns. Picture remove.	
		8.24 : Use of OFP RAMP and LNDG fuel correction figures	Added a note regarding usage of the LAND/RAMP correction with large ZFW changes.	
		8.26 : Final ZFW – What do we do with that?	Updated image from SOP NP's. Added a note that after F.ZFW comes in the CM1/2 should confer and decide RAMP, TAXI and TRIP fuels before proceeding with the calculation/calculation cross check.	
		8.29 : Cleared to disconnect external power Captain?	Amended to include a requirement for engineering to confirm external power disconnection with Flight Deck.	
		8.30 : Pre-Start Hydraulic Pressurisation	Adjusted for the coming FCOM amendment removing the FAULT light extinguished requirement.	
		8.31 : Dispatch with the DDG – what does “None” really mean?	Discusses the meaning of “None” in the DDG EICAS message List.	
		9.2 : Pushback Sequence	Noted added on CM2 continuing flow.	
		9.5 : Engine Number One or Left Engine	Moved from Section 8.	
		9.6 : Fuel Control Switch to RUN During Start	Moved from Section 8.	
		9.9 : Clear to disconnect after Recall	Added a note to explain the function of the EICAS Recall after start.	
		9.11 : Guarding Fuel Control Switches	Addition discussing the non-requirement for guarding fuel control switches during engine start.	
		10.7 : Taxi Technique – General Tips	Entry added on paralleling technique, and pictures.	
		11.5 : “Takeoff” ... Then TOGA Switch	Updated to reflect the amended procedure for CM1 conducting both low and high speed rejected takeoffs.	
		11.6 : Thrust Handover and Engine Malfunctions	Paragraph removed; awaiting final clearance from SOP committee on Thrust Handover procedures. 12 months and still waiting ...	
		11.7 : Increasing VR for Strong Crosswind Conditions / Windshear	Amended to reflect the requirement for TOGA thrust Added notes on “improved climb”	
		11.8 : Flap Retraction & Extension	Added a note about (not) calling “Non Standard” Flap 15; recommending against using Flap 25	
		11.10 : VNAV Path after Take Off?	Clarified	
		12.1 : Filling in a Flight Plan	Updated Text and Picture (Contingency Summary Page & Nav Log)	
		12.2 : EDTO Critical Fuel Check	Updates picture – recording ETP Time/Fuel. Amended text regarding Lat/Lon entry and added track check. Amended technique of using Prog Page (Morty)	
		12.3 : EDTO Critical Fuel – Do We Need It?	Clarification on in flight EDTO Critical Fuel Requirement.	
		12.11 : Totalizer vs Calculated Fuel	Clarified Totalizer vs Calculated basis.	
		12.12 : HF Radio Usage	Expanded detail on suggested HF usage.	
		12.13 : VHF Radio/RTP Usage	Discussing standard VHF usage and offside RTP-VHF issues. Include a specific example of CM3 using VHF-C during taxi/descent	
		12.22 : Enroute CDL Performance Penalties	Discussion on possible techniques to check for the likely impact on single engine altitude capability of CDL enroute performance decrements.	
		12.23 : When do you do the Recall and Notes?	Updated personal technique on commencing Arrival Briefing iaw Descent Checklist.	
		13.1 : VNAV Approach Validation	Updated to reference WGS-84 validation.	
		13.2 : VNAV Approach – No Path Indicator	Added a note on the likely impact of using the cruise altitude method to correct no VNAV Path indication.	
		13.3 : Alternate MCP Altitude Setting Technique	Revised to reflect FCTM update as applicable to climb/desc/appr. Diagram added for clarity.	
		13.6 : VNAV Approach – Speed Jumps Up	Updated to address the practice of modifying the CDU VNAV Descent page prior to the approach.	
		13.8 : FLCH during NPA's	Clarified successful VNAV SPD usage to capture Above Path on approach.	
		13.13 : Parallel Runway Awareness	Added to highlight the need for Parallel Runway awareness during vectoring for final.	
		13.15 : Localiser Approaches – FMC Selection	Clarified the requirement to select a LOC approach in the FMC when it's available and flying a Localizer approach. Added summary table.	
		13.17 : Glideslope Intercept From Above	Re-worded manual approach capture from above	
		13.18 : Circling Minima	Amended to align with the A1's airfield elevation requirement.	



Date	Author	Paragraphs Affected	Change Descriptions	Ver
23.Feb.11	KP	13.20 : ILS Approach to Circle	Included a reference to LAND 3 @ 1500 ft and Mode Change inhibit.	1.9
		13.22 : Flt Director OFF at Minima?	Included a reference to approaches that require a m/app turn prior to the runway and therefore require FD's off at MDA.	
		13.23 : Unnecessary Actions during Circling Approaches	Added a note to suggest that thoughtful, early preparation can replace these workload procedures during circling.	
		13.27 : Boeing Thrust Reference Setting Anomaly	Describes the thrust limit setting anomaly that impacts during VNAV approaches.	