

# Sling

## Sling 2 and Sling LSA

Serial No : \_\_\_\_\_

Registration : \_\_\_\_\_



DC - MAM- 002 - X - B - 2

### MAINTENANCE MANUAL



Date of issue : 2014/11/10

Revision 2.2

THE AIRPLANE FACTORY | HANGAR 8 TEDDERFIELD AIRPARK,  
EIKENHOF, JHB SOUTH, 1872  
PO BOX 308, EIKENHOF, 1872, SOUTH AFRICA  
Phone : +27 11 948 9898 | Information : info@airplanefactory.co.za

## **GENERAL INFORMATION**

---

This manual / document is written to reflect the standard ready-to-fly SLING 2 and SLING LSA aircraft as delivered from The Airplane Factory and does not address particular aircraft differing from the delivery standard.

Equipment fitted to the aircraft must be done so in accordance to the requirements of the national regulations of the country of registration.

PLEASE ADVISE THE AIRPLANE FACTORY ON CHANGE  
OF OWNERSHIP OF THE AIRCRAFT.

### **NOTICE**

THIS EDITION OF THIS MANUAL IS APPLICABLE TO AIRCRAFT REGISTERED IN THE REPUBLIC OF SOUTH AFRICA. DEFINITIONS ARE ACCORDINGLY CONSISTENT WITH RSA REGULATIONS ONLY.



---

## PRESENTATION

---

This manual is divided into the following sections:

**SECTION 1 – GENERAL:** This section provides general information, capacities and general procedures and specifications.

**SECTION 2 – INSPECTION:** This section provides information regarding general inspection considerations, inspection schedules and inspection procedures.

**SECTION 3 – SERVICE:** This section provides information regarding general service considerations and service schedules.

**SECTION 4 – STRUCTURES, SYSTEMS AND PROCEDURES:** This section describes the various structures, substructures, systems and subsystems comprising the aircraft, and describes maintenance procedures applicable to these structures, substructures, systems and subsystems, as the case may be.

### APPENDICES

Provides useful additional information.

## REVISION RECORD

---

REVISION NUMBER	DATE	DESCRIPTION OF CHANGE	PARAGRAPHS	SIGN
1.0	2010/01/01	Original document.	N/A	
2.0	2012/03/01	All	All	
2.1	2012/11/012	All	All	
2.2	2014/11/10	All	All	

## LIST OF ACRONYMS

---

AC	Alternating Current
A/C	Aircraft
A/H	Ampere Hour
AHRS	Attitude and Heading Reference System
AKI	Anti Knock Index
AOA	Angle Of Attack
API	American Petroleum Institute
ATF	Authority To Fly
ATF	Automatic Transmission Fluid
AUX	Auxilliary
AVGAS	Aviation Gasoline
AWG	American Wire Gauge
BATT	Battery
BNC	Bayonet Neill Concelman (connector type)
BRS	Ballistic Recovery System
C	Common
CAN	Controller Area Network
CG	Centre of Gravity
DC	Direct Current
ECU	Engine Control Unit
EFIS	Electronic Flight Information System
EMS	Engine Management System
EXT	External
FAA	Federal Aviation Authority
GLS	GPS Landing System
GmbH	Gesellschaft mit beschränkter Haftung (company with limited liability).
GND	Ground
GPS	Global Positioning System
ID	Inner Diameter
IGN	Ignition
KIAS	Indicated airspeed (Knots)
LAN	Local Area Network

MAC	Mean Aerodynamic Chord
MIC	Microphone
MOGAS	Motorcar Gasoline
NC	Normally Closed
NGL	Normal Ground Line
NO	Normally Open
NRV	Non Return Valve
PASS	Passenger
POH	Pilot Operating Handbook
PTT	Push-To-Talk
QFE	Setting on altimeter subscale equal to ambient atmospheric pressure at a specified datum
QNH	Barometric pressure adjusted to sea level
RCA	Radio Corporation of America (connector type)
RDAC	Remote Data Acquisition Computer
RON	Research Octane Number
RSA	Republic of South Africa
RS232	Recommended Standard 232
RX	Receive
SCN	Screen (wire)
SPST	Single Pole Single Throw (switch contact(s) configuration)
SW	Switch
TCU	Turbocharger Control Unit
TX	Transmit
US	United States (of America)
USB	Universal Serial Bus
VHF	Very High Frequency
VMC	Visual Meteorological Conditions
VSI	Vertical Speed Indicator

## REFERENCED DOCUMENTS

The following documents are referred to / mentioned in this document and should be read in conjunction with this document, as applicable.

DOCUMENT / TITLE	
1	FAA Advisory Circular AC43.13-1B: Acceptable Methods, Techniques and Practices - Aircraft Inspection and Repair.
2	AP3 Series and AP4 Series Constant Speed Propeller Operator's Manual.
3	Warp Drive HPL-R Hub Assembly Instructions and Warp Drive Protractor Instructions.
4	Whirlwind Propellers RW3B Propeller Installation and Operation Rotax Engines 912 / 914.
5	Rotax Service Information SI-912i-001.
6	Rotax Service Information SI-912-016.
7	Rotax Service Information SI-914-019.
8	Maintenance Manual (Heavy Maintenance) for Rotax Engine Types Rotax 912 and Rotax 914 Series (Reference no. MMH-914).
9	Maintenance Manual (Line Maintenance) for Rotax Engine Type 914 Series.
10	Operators Manual for Rotax Engine Type 914 Series (Reference no. OM-914).
11	Installation Manual for Rotax Engine Type 914 Series (Reference no. IM-914).
12	Maintenance Manual (Line Maintenance) for Rotax Engine Type 912 Series.
13	Operators Manual for Rotax Engine Type 912 Series (Reference no. OM-912).
14	Installation Manual for Rotax Engine Type 912 Series.
15	Maintenance Manual (Heavy Maintenance) for Rotax Engine Types Rotax 912i Series (Reference no. MMH-912i).
16	Maintenance Manual (Line Maintenance) for Rotax Engine Type 912i Series (Reference no. MML-912i).
17	Operators Manual for Rotax Engine Type 912i Series (Reference no. OM-912i).
18	Installation Manual for Rotax Engine Type 912i Series (Reference no. IM-912i).
19	MGL Avionics EFIS Integrated Autopilot user and Installation Manual.
20	ASTM D7547: Standard Specification for Hydrocarbon Unleaded Aviation Gasoline.
21	ASTM D910: Standard Specification for Aviation Gasolines.
22	ASTM D4814: Standard Specification for Automotive Spark-Ignition Engine Fuel.
23	DIN EN 228: Automotive Fuels - Unleaded Petrol - Requirements and Test Methods.

---

24	RDAC XF Installation Manual (MGL Avionics).
25	MIL-G-3278: Military Specification - Grease, Aircraft and Instrument (For Low and High Temperatures).
26	MIL-C-16173: Military Specification – Corrosion Preventive Compound, Solvent Cutback, Cold Application.
27	MIL-C11796: Military Specification - Corrosion Preventive Compound, Petrolatum, Hot Application
28	AMS-S-8802: Sealing Compound, Temperature Resistant, Integral Fuel Tanks and Fuel Cell Cavities, High Adhesion.
29	MGL Avionics iBOX V1 Installation Manual.
30	MIL-G-81322: Military Specification – Grease, Aircraft, General Purpose, Wide Temperature Range.
31	iEFIS Panel Installation Manual (MGL Avionics).



## TABLE OF CONTENTS

1.	GENERAL .....	1
1.1.	DESCRIPTION .....	1
1.2.	AIRCRAFT SPECIFICATIONS AND DATA .....	2
1.2.1	AIRCRAFT 3-VIEW DRAWING.....	2
1.2.2	AIRCRAFT GEOMETRIC DIMENSIONS.....	4
1.2.3	AIRCRAFT WEIGHTS.....	5
1.3.	ENGINE.....	6
1.4.	APPROVED SUBSTANCES, FLUIDS, LUBRICANTS AND CAPACITIES.....	8
1.5.	FASTENER TORQUE VALUES AND WRENCH SIZE(S).....	13
1.5.1	GENERAL .....	13
1.5.2	SPECIFIC .....	13
1.6.	EQUIPMENT LIST .....	14
1.7.	SPECIFICATION AND PRESSURES.....	15
1.8.	GROUND HANDLING .....	15
1.9.	PARKING AND TIE DOWN.....	16
1.10.	JACKING .....	16
1.11.	AIRCRAFT LEVELLING.....	17
1.11.1	LONGITUDINAL LEVELLING .....	17
1.11.2	TRANSVERSE LEVELLING .....	19
1.12.	AIRCRAFT ALIGNMENT .....	21
1.13.	CONTROL SURFACE DEFLECTION / TRAVEL.....	23
1.14.	RUDDER CONTROL CABLE TENSION .....	23
1.15.	AIRCRAFT RIGGING.....	24
1.15.1	RUDDER CABLE TENSION ADJUSTMENT.....	24
1.15.2	ELEVATOR ADJUSTMENT .....	24
1.15.3	ELEVATOR TRIM TAB ADJUSTMENT .....	24
1.15.4	AILERON ADJUSTMENT .....	24
1.15.5	FLAP ADJUSTMENT .....	24
1.16.	WEIGHT AND BALANCE INFORMATION .....	25
1.16.1	REQUIREMENT / SCHEDULE .....	25
1.16.2	MOMENT ARMS .....	25
1.16.3	CENTRE OF GRAVITY FORMULAE.....	26
1.16.4	EMPTY WEIGHT CENTRE OF GRAVITY TABLE .....	26
1.16.5	EMPTY WEIGHT CENTRE OF GRAVITY DETERMINATION.....	27

1.17.	AIRCRAFT STORAGE.....	29
1.17.1	SHORT TERM STORAGE.....	29
1.17.2	MEDIUM TO LONG TERM STORAGE.....	29
1.17.3	OUTSIDE STORAGE.....	30
1.17.4	RETURNING THE AIRCRAFT TO SERVICE.....	30
1.18.	CORROSION PREVENTION.....	31
1.19.	SOURCES FOR THE PURCHASING OF PARTS.....	33
1.20.	DISPOSABLE REPLACEMENT PARTS.....	33
1.21.	AIRCRAFT PLACARDS AND EQUIPMENT LABELLING.....	34
1.21.1	MARKINGS AND PLACARDS.....	34
2.	INTRODUCTION.....	43
2.1.	GENERAL CONSIDERATIONS REGARDING INSPECTION.....	43
2.2.	INSPECTION PANELS.....	46
2.3.	INSPECTION SCHEDULE.....	47
2.3.1	ENGINE.....	47
2.3.2	PROPELLER.....	47
2.3.3	AIRFRAME AND SYSTEMS.....	47
2.4.	CONDITION INSPECTION (100 HOUR / ANNUALLY).....	48
2.4.1	INSPECTION PANELS AND INITIAL INSPECTION AND CLEANING.....	48
2.4.2	FUSELAGE GROUP.....	48
2.4.3	CABIN AND COCKPIT GROUP.....	48
2.4.4	ENGINE AND COWLING GROUP.....	49
2.4.5	LANDING GEAR GROUP.....	49
2.4.6	WING AND CENTRE SECTION ASSEMBLY.....	50
2.4.7	EMPENNAGE ASSEMBLY.....	50
2.4.8	PROPELLER GROUP.....	50
2.4.9	RADIO GROUP / AVIONICS / ELECTRONIC EQUIPMENT.....	51
2.4.10	OPTIONAL EQUIPMENT.....	51
2.5.	25 HOUR, 100 HOUR AND ANNUAL SERVICE INSPECTION CHECKLIST.....	52
3.1	LUBRICATION POINTS, LUBRICANTS AND INTERVALS.....	67
3.2	SERVICE BULLETINS.....	67
3.3	SERVICE SCHEDULE.....	67
3.3.1	SERVICE PERIOD ADJUSTMENT.....	68
3.3.2	ITEMS WITH CALENDAR BASED SERVICING.....	69
3.3.3	DAILY.....	70
3.3.4	AS NEEDED.....	70
3.3.5	FIRST 25 HOURS.....	70

3.3.6	FIRST 50 HOURS .....	71
3.3.7	EVERY 50 HOURS / ANNUALLY .....	71
3.3.8	EVERY 100 HOURS / ANNUALLY .....	72
4.	AIRFRAME .....	73
4.1	WING .....	74
4.1.1	MAIN WING SECTION.....	74
4.1.1.1	WING REMOVAL / INSTALLATION .....	75
4.1.2	AILERON(S) .....	81
4.1.2.1	AILERON CONTROL SYSTEM .....	81
4.1.2.2	AILERON REMOVAL / INSTALLATION .....	82
4.1.2.3	AILERON ADJUSTMENT .....	87
4.1.2.4	AILERON AUTOPILOT SERVO REMOVAL / INSTALLATION .....	91
4.1.3	FLAPS .....	95
4.1.3.1	FLAP CONTROL SYSTEM .....	95
4.1.3.2	FLAP REMOVAL / INSTALLATION .....	96
4.1.3.3	FLAP ADJUSTMENT .....	102
4.1.3.4	FLAP ACTUATOR MOTOR REMOVAL / INSTALLATION.....	104
4.2	EMPENNAGE.....	107
4.2.1	HORIZONTAL TAIL AND ELEVATOR.....	107
4.2.1.1	ELEVATOR CONTROL SYSTEM.....	108
4.2.1.2	ELEVATOR REMOVAL / INSTALLATION.....	109
4.2.1.3	HORIZONTAL STABILIZER REMOVAL / INSTALLATION .....	113
4.2.1.4	ELEVATOR TRIM TAB MOTOR REMOVAL / INSTALLATION .....	116
4.2.1.5	ELEVATOR ADJUSTMENT .....	119
4.2.1.6	ELEVATOR TRIM TAB ADJUSTMENT .....	122
4.2.1.7	ELEVATOR AUTOPILOT SERVO REMOVAL / INSTALLATION.....	124
4.2.2	VERTICAL TAIL AND RUDDER .....	128
4.2.2.1	RUDDER CONTROL SYSTEM.....	129
4.2.2.2	RUDDER REMOVAL / INSTALLATION.....	130
4.2.2.3	VERTICAL STABILIZER REMOVAL.....	134
4.2.2.4	RUDDER PEDAL ADJUSTMENT .....	138
4.2.2.5	RUDDER CABLE TENSION ADJUSTMENT .....	139
4.3	FUSELAGE .....	142
4.3.1	REAR FUSELAGE .....	142
4.3.2	CENTRE FUSELAGE .....	143
4.3.2.1	SEAT REMOVAL AND INSTALLATION .....	143

4.3.2.2	CANOPY AND WINDSHIELD CLEANING .....	145
4.3.2.3	UPHOLSTERY CLEANING.....	145
4.3.3	FORWARD FUSELAGE AND FIREWALL.....	146
4.4	LANDING GEAR .....	147
4.4.1	MAIN GEAR .....	147
4.4.1.1	MAIN WHEEL FAIRING REMOVAL / INSTALLATION .....	148
4.4.1.2	MAIN WHEEL REMOVAL / INSTALLATION .....	150
4.4.1.3	MAIN WHEEL AXLE AND BRAKE MECHANISM REMOVAL.....	153
4.4.1.4	MAIN WHEEL DISASSEMBLY / ASSEMBLY.....	157
4.4.1.5	MAIN WHEEL BEARING REMOVAL / INSTALLATION AND LUBRICATION.....	160
4.4.1.6	MAIN GEAR REMOVAL / INSTALLATION.....	161
4.4.2	NOSE GEAR .....	166
4.4.2.1	NOSE WHEEL FAIRING REMOVAL / INSTALLATION .....	167
4.4.2.2	NOSE WHEEL REMOVAL / INSTALLATION.....	168
4.4.2.3	NOSE WHEEL DISASSEMBLY / ASSEMBLY .....	171
4.4.2.4	NOSE WHEEL BEARING REMOVAL / REPLACEMENT .....	174
4.4.2.5	NOSE GEAR REMOVAL / INSTALLATION.....	175
5.	POWER PLANT .....	178
5.1	COWLING .....	178
5.1.1	COWLING REMOVAL / INSTALLATION.....	179
5.2	ENGINE.....	182
5.2.1	GENERAL MAINTENANCE AND SERVICING .....	182
5.2.2	CARBURETTOR SYNCHRONISATION (914 UL AND 912 ULS).....	182
5.2.3	REPLACING ENGINE OIL.....	182
5.2.4	REPLACING ENGINE COOLANT .....	182
5.2.5	SPARK PLUG REPLACEMENT .....	183
5.2.6	VERIFYING ENGINE OIL LEVEL .....	184
5.2.7	AIR FILTER REMOVAL, CLEANING AND REPLACEMENT (914 UL).....	185
5.2.8	AIR FILTER REMOVAL, CLEANING AND REPLACEMENT (912 IS) .....	188
5.2.9	AIR FILTER REMOVAL, CLEANING AND REPLACEMENT (912 ULS).....	191
5.2.10	MUFFLER / HEAT EXCHANGER ASSEMBLY REMOVAL / REPLACEMENT (914 UL) .....	193
5.2.11	MUFFLER / HEAT EXCHANGER ASSEMBLY REMOVAL / REPLACEMENT (912 ULS / 912 IS) .. .....	195
5.2.12	MUFFLER / HEAT EXCHANGER DISASSEMBLY / ASSEMBLY (914 UL).....	197
5.2.13	MUFFLER / HEAT EXCHANGER DISASSEMBLY / ASSEMBLY (912 ULS / 912 IS).....	199
5.2.14	REMOVAL / INSTALLATION OF OIL AND COOLANT RADIATORS.....	201

5.2.15	OIL COOLER / RADIATOR PIPE CONNECTION / DISCONNECTION.....	202
5.2.16	COOLANT RADIATOR PIPE CONNECTION / DISCONNECTION .....	205
5.2.17	ENGINE REMOVAL / INSTALLATION (914 UL) .....	207
5.2.18	ENGINE REMOVAL / INSTALLATION (912 ULS / 912 IS) .....	214
5.2.19	ENGINE CONTROL SYSTEM (THROTTLE AND CHOKE) .....	221
5.2.19.1	THROTTLE LEVER FRICTION ADJUSTMENT .....	222
5.2.19.2	THROTTLE LEVER FRICTION DISC REPLACEMENT.....	223
5.3	PROPELLER.....	225
5.3.1	GENERAL MAINTENANCE AND SERVICE .....	225
5.3.2	PROPELLER HUB AND PROPELLER EXTENSION TORQUE PATTERN.....	225
5.3.3	SPINNER REMOVAL / REPLACEMENT.....	226
5.3.4	GENERAL CONSIDERATIONS / INFORMATION WHEN FITTING A PROPELLER EXTENSION TO THE ENGINE FLANGE .....	228
5.3.5	PROPELLER REMOVAL / INSTALLATION (AIRMASTER 332).....	229
5.3.6	PROPELLER REMOVAL / INSTALLATION (WHIRLWIND).....	238
5.3.7	PROPELLER REMOVAL / INSTALLATION (WARP DRIVE) .....	241
5.3.8	PROPELLER ASSEMBLY / DISASSEMBLY (AIRMASTER 332) .....	243
5.3.9	PROPELLER ASSEMBLY / DISASSEMBLY (WARP DRIVE) .....	246
5.3.10	PROPELLER ASSEMBLY / DISASSEMBLY (WHIRLWIND).....	246
5.3.11	PROPELLER ADJUSTMENT / SET-UP .....	246
5.3.12	PROPELLER BALANCING .....	246
6.	FUEL SYSTEM.....	247
6.1	GENERAL INFORMATION AND CONSIDERATIONS.....	247
6.2	FUEL FILTER REPLACEMENT.....	258
6.2.1	INSIDE CABIN (912 ULS, 912 IS, 914 UL).....	258
6.2.2	FIREWALL FORWARD (912 IS).....	260
6.2.3	FIREWALL FORWARD (912 ULS) .....	262
6.3	FUEL SELECTOR UNIT REMOVAL / INSTALLATION.....	263
6.4	FUEL SELECTOR UNIT ASSEMBLY / DISASSEMBLY .....	266
6.5	FUEL PUMP ASSEMBLY REMOVAL / INSTALLATION (914 UL).....	268
6.6	FUEL PUMP REMOVAL / INSTALLATION FROM / IN FUEL PUMP ASSEMBLY (914 UL).....	274
6.7	FUEL PUMP ASSEMBLY REMOVAL / INSTALLATION (912 IS).....	276
6.8	FUEL PUMP REMOVAL / INSTALLATION FROM / IN FUEL PUMP ASSEMBLY (912 IS).....	276
6.9	ELECTRIC FUEL PUMP REMOVAL / INSTALLATION (912 ULS) .....	277
6.10	FUEL TANK LEAK REPAIR.....	280
6.11	FUEL TANK DRAIN REMOVAL / INSTALLATION (DRAINING WING TANK) .....	281
6.12	FUEL LEVEL SENDER ASSEMBLY REMOVAL / INSTALLATION (FROM / TO FUEL TANK).....	283

6.13	REPLACING FUEL LEVEL SENDER ASSEMBLY SENSOR .....	287
6.14	FINGER STRAINER (ON FUEL PICK-UP) INSPECTION.....	291
7.	AVIONICS AND INSTRUMENTS.....	293
7.1	GENERAL MAINTENANCE AND SERVICE OF INSTRUMENTS .....	294
7.2	REMOVAL / INSTALLATION OF INSTRUMENT PANEL AND INSTRUMENTS.....	295
7.3	PITOT AND STATIC SYSTEMS .....	297
7.3.1	PITOT SYSTEM LEAK TEST.....	298
7.3.2	STATIC SYSTEM LEAK TEST .....	299
7.3.3	PITOT AND / OR STATIC SYSTEM CLEANING AND SERVICING .....	300
7.4	AHRS AND COMPASS.....	301
7.4.1	AHRS AND / OR COMPASS SENSOR REMOVAL / INSTALLATION.....	301
7.5	HEADPHONE SOCKETS .....	303
7.5.1	HEADPHONE SOCKET REMOVAL / INSTALLATION .....	303
7.6	ANTENNAE .....	306
7.6.1	VHF COMMUNICATION ANTENNA.....	306
7.6.1.1	VHF ANTENNA REMOVAL / INSTALLATION.....	306
7.6.2	GPS ANTENNA.....	308
7.6.2.1	GPS ANTENNA REMOVAL / INSTALLATION .....	308
8.	UTILITY SYSTEMS.....	310
8.1	CABIN HEATING AND COOLING .....	310
8.1.1	HEAT EXCHANGER ASSEMBLY REMOVAL AND INSTALLATION .....	310
9.	BRAKE SYSTEM .....	311
9.1	BRAKE FLUID DRAINING, REPLACEMENT AND BRAKE SYSTEM BLEEDING.....	312
9.2	BRAKE MECHANISM REMOVAL / INSTALLATION.....	314
9.3	BRAKE DISC REPLACEMENT.....	315
9.4	BRAKE LINING REPLACEMENT .....	316
10.	ELECTRICAL SYSTEM .....	319
10.1	BATTERY REMOVAL / INSTALLATION .....	323
10.2	EFIS BACK-UP BATTERY REMOVAL / INSTALLATION .....	325
10.3	ALTERNATOR MAINTENANCE .....	327
10.4	REPLACEMENT OF CIRCUIT BREAKERS AND / OR SWITCHES.....	327
10.5	REGULATOR / RECTIFIER REMOVAL AND REPLACEMENT .....	330
11.	EXTERIOR LIGHTING .....	332
11.1	NAVIGATION LIGHTS .....	332
11.1.1	NAVIGATION LIGHT REMOVAL / INSTALLATION .....	333
11.2	LANDING AND TAXI LIGHTS.....	335

11.2.1	LANDING AND / OR TAXI LIGHT REMOVAL / INSTALLATION .....	335
11.2.2	LANDING AND / OR TAXI LIGHT REPLACEMENT .....	338
11.2.3	LANDING AND / OR TAXI LIGHT ADJUSTMENT .....	340
11.3	STROBE LIGHT .....	341
11.3.1	STROBE LIGHT REMOVAL / INSTALLATION.....	341
12.	EMERGENCY AND SAFETY SYSTEMS .....	343
12.1	BALLISTIC PARACHUTE .....	343
12.1.1	GENERAL SERVICE AND MAINTENANCE. ....	343
12.2	SAFETY HARNESSSES .....	344
12.2.1	REMOVAL / INSTALLATION OF SAFETY BELT(S) .....	344
13.	APPENDIX A (AVIONICS AND ELECTRICAL SYSTEM WIRING DIAGRAMS) .....	347
13.1	CHARGE AND START SYSTEM / FUEL PUMPS WIRING DIAGRAM (914 UL) .....	347
13.2	CHARGE AND START SYSTEM / FUEL PUMPS WIRING DIAGRAM (912 ULS).....	348
13.3	EXTERNAL ALTERNATOR WIRING DIAGRAM (914 UL / 912 ULS).....	349
13.4	ELECTRICAL SYSTEM / FUEL PUMPS WIRING DIAGRAM (912 IS) .....	350
13.5	SWITCHES AND CIRCUIT BREAKERS WIRING DIAGRAM (914 UL) .....	351
13.6	SWITCHES AND CIRCUIT BREAKERS WIRING DIAGRAM (912 ULS).....	352
13.7	SWITCHES AND CIRCUIT BREAKERS WIRING DIAGRAM (912 IS) .....	353
13.8	FLAP SYSTEM WIRING DIAGRAM .....	354
13.8.1	MGL SP10 FLAP CONTROL WITH 4 POSITION ROTARY SWITCH .....	354
13.8.2	INOTEC FLAP SYSTEM .....	355
13.8.3	E-FLAPS.....	356
13.9	ELEVATOR TRIM MOTOR WIRING DIAGRAM.....	357
13.9.1	DUAL STICK TRIM .....	357
13.9.2	SINGLE STICK TRIM.....	358
13.10	EFIS SYSTEM / COMMUNICATIONS BUS LAYOUT .....	359
13.10.1	912 IS INSTALLATION .....	359
13.10.2	914 UL / 912 ULS INSTALLATION .....	360
13.11	AHRS AND COMPASS WIRING DIAGRAM .....	361
13.12	AUTOPILOT ROLL SERVO AND PITCH SERVO WIRING DIAGRAM .....	362
13.13	EFIS BACK-UP BATTERY CHARGE CIRCUIT.....	363
13.14	HEADPHONE / RADIO WIRING DIAGRAM (MGL V6) .....	364
13.15	MGL V6 RADIO CONNECTOR PIN DIAGRAM.....	365
13.16	POSITION / NAVIGATION LIGHTS WIRING DIAGRAM.....	366
13.17	OIL PRESSURE TRANSDUCER TO RDAC WIRING DIAGRAM (914 UL / 912 ULS).....	367
3.1	DUAL EFIS INSTALLATION WIRING DIAGRAM.....	368
3.2	TRANSPONDER (IF FITTED) WIRING DIAGRAMS.....	369

---

3.2.1	TRIG TT21 TRANSPONDER (IF FITTED) WIRING DIAGRAM .....	369
3.1.1	SANDIA STX 165R TRANSPONDER (IF FITTED) WIRING DIAGRAM .....	370
3.2	ENGINE MONITORING TRANSDUCERS (SENSORS) / RDAC ELECTRICAL WIRING .....	371
3.3	EFIS AND IBOX ELECTRICAL WIRING .....	371
3.4	PROPELLER AND PROPELLER CONTROLLER ELECTRICAL WIRING INFORMATION (AIRMASTER PROPELLER) .....	371
3.5	ROTAX 912 ULS / 912 IS / 914 UL ENGINE ELECTRICAL WIRING INFORMATION.....	371
4.	APPENDIX B (FIREWALL MOUNTED EQUIPMENT) .....	372
4.1	ROTAX 914 UL .....	372
4.2	ROTAX 912 IS.....	373
4.3	ROTAX 912 ULS .....	374
5.	APPENDIX C (GENERAL PROCEDURES AND TECHNIQUES NOT DESCRIBED ELSEWHERE) .....	375
5.1	REMOVAL OF TWO-EAR CLAMPS.....	375
5.2	PUSHROD ADJUSTMENT .....	375
5.3	FITTING OF FIRE RESISTANT SLEEVING OVER OIL AND FUEL LINES / HOSES.....	376
6.	APPENDIX D (GENERAL PROCEDURES FOR PREPARATION FOR TRIAL RUN OF ENGINE) .. .....	377
7.	APPENDIX E (AN WASHER AND NUT HARDWARE DESIGNATIONS).....	378



## LIST OF FIGURES

Figure 1: Longitudinal leveling reference position. ....	18
Figure 2: Transverse leveling reference position. ....	20
Figure 3: Aircraft alignment. ....	21
Figure 4: Moment arms. ....	25
Figure 5: Front wing spar to fuselage connection. ....	78
Figure 6: Rear wing spar to fuselage connection. ....	79
Figure 7: Aileron pushrod-to-control stick connection. ....	79
Figure 8 : Aileron control system. ....	81
Figure 9: Aileron hinge (inboard). ....	84
Figure 10: Aileron hinge (outboard). ....	85
Figure 11: Aileron pushrod -to-bellcranck connection. ....	86
Figure 12: Aileron adjustment - cabin side. ....	88
Figure 13: Aileron adjustment - wing side. ....	89
Figure 14: Autopilot aileron servo installation. ....	93
Figure 15: Flap control system. ....	95
Figure 16: Flap hinges. ....	98
Figure 17: Flap pushrod-to-flap connection. ....	99
Figure 18: Flap pushrod-to-flap torque tube control arm connection. ....	101
Figure 19: Flap actuator motor removal. ....	105
Figure 20: Flap actuator motor installation. ....	106
Figure 21: Horizontal tail and elevator. ....	107
Figure 22: Elevator control system. ....	108
Figure 23: Elevator pushrod to elevator connection. ....	111
Figure 24: Horizontal stabilizer-to-elevator hinge connection. ....	112
Figure 25: Horizontal stabilizer to fuselage attachment. ....	115
Figure 26: Elevator adjustment. ....	120
Figure 27: Autopilot elevator servo installation. ....	126
Figure 28: Vertical tail and rudder. ....	128
Figure 29: Rudder control system. ....	129
Figure 30: Rudder to vertical stabilizer hinge connection. ....	132
Figure 31: Rudder cable connection. ....	133
Figure 32: Vertical stabilizer to fuselage connection. ....	136
Figure 33 : Rudder cable tension adjustment. ....	140

---

Figure 34: Main landing gear.....	147
Figure 35: Main wheel axle installation. ....	156
Figure 36: Main gear installation (no parachute).....	164
Figure 37: Main gear installation (with parachute). ....	165
Figure 38: Nose gear.....	166
Figure 39: Nose wheel installation. ....	170
Figure 40: Front wheel hub assembly. ....	173
Figure 41: Nose gear installation.....	177
Figure 42: Engine cowling. ....	178
Figure 43: Engine removal (912 ULS, 912 iS). ....	211
Figure 44: Engine installation (914 UL). ....	212
Figure 45: Engine removal (912 ULS, 912 iS). ....	217
Figure 46: Engine installation (912 ULS, 912 iS) ....	219
Figure 47: Throttle lever friction disc installation. ....	224
Figure 48: Propeller installation / propeller extension installation torque pattern.....	225
Figure 49: Airmaster propeller installation (standard). ....	232
Figure 50: Airmaster propeller signal wire to slip-ring disc connection (vacuum pump fitted). ....	235
Figure 51: Airmaster propeller installation (with vacuum pump fitted). ....	236
Figure 52: Airmaster propeller installation (external alternator fitted). ....	237
Figure 53: Whirlwind propeller installation.....	240
Figure 54: Fuel system (914 UL - SLING 2).....	248
Figure 55: Fuel system (912 ULS - SLING 2). ....	250
Figure 56: Fuel system (912 iS - SLING 2). ....	252
Figure 57: Fuel system (912 ULS - SLING LSA) ....	254
Figure 58: Fuel system (912 iS - SLING LSA) ....	256
Figure 59: Fuel selector unit installation.....	265
Figure 60: Fuel selector port allocation and fitting orientation. ....	267
Figure 61: Fuel selector fuel fitting alignment. ....	267
Figure 62: Electric fuel pump fitment / assembly (912 ULS). ....	279
Figure 63: Wing tank fuel drain installation. ....	282
Figure 64: Fuel sender installation into fuel tank.....	286
Figure 65: Fuel level sender assembly sensor replacement.....	290
Figure 66: Standard instrument panel. ....	293
Figure 67: Representative pitot and static system. ....	297
Figure 68: Headphone socket installation. ....	305
Figure 69: VHF antenna installation. ....	307
Figure 70: Brake system.....	311

---

Figure 71: Electrical system – 914 UL equipped aircraft (overview).....	319
Figure 72: Electrical system – 912 ULS equipped aircraft (overview).....	320
Figure 73: Electrical system – 912 iS equipped aircraft (overview).....	321
Figure 73 : Landing and taxi light installation.....	337
Figure 74: Charge and start system wiring diagram /fuel pump wiring (914 ULS).....	347
Figure 75: Charge and start system wiring diagram /fuel pump wiring (912 ULS).....	348
Figure 76: External alternator wiring diagram (914 UL / 912 ULS).....	349
Figure 77: 912 iS electrical wiring diagram.....	350
Figure 79: Switches and circuit breakers wiring diagram (914 UL).....	351
Figure 79: Switches and circuit breakers wiring diagram (912 ULS).....	352
Figure 80: Switches and circuit breakers wiring diagram (912 iS).....	353
Figure 81: MGL SP10 flap controller.....	354
Figure 82: Flap system wiring diagram – INOTEC.....	355
Figure 83: Flap system wiring diagram - E-Flaps.....	356
Figure 84: Elevator trim motor wiring diagram – dual control sticks.....	357
Figure 85: Elevator trim motor wiring diagram – single control stick.....	358
Figure 85: EFIS system / communications bus layout - 912 iS.....	359
Figure 87: EFIS system / communications bus layout – 914 UL / 912 ULS.....	360
Figure 88: AHRS and compass wiring diagram.....	361
Figure 89: Autopilot roll servo and pitch servo wiring diagram.....	362
Figure 90: EFIS back-up battery charge circuit.....	363
Figure 91: Headphone / radio / intercom wiring diagram (MGL V6).....	364
Figure 90: MGL V6 radio connector pin diagram.....	365
Figure 91: Position / navigation lights wiring diagram.....	366
Figure 95: RDAC to oil pressure transducer wiring diagram and settings (914 UL / 912 ULS).....	367
Figure 96: Dual EFIS installation wiring diagram.....	368
Figure 96: TRIG TT21 transponder (if fitted) wiring diagram.....	369
Figure 97: SANDIA STX 165R transponder (if fitted) wiring diagram.....	370
Figure 93: Firewall forward mounted equipment (914 UL).....	372
Figure 94: Firewall forward mounted equipment (912 iS).....	373
Figure 95: Firewall forward mounted equipment (912 ULS).....	374
Figure 96: Two-ear clamp removal.....	375
Figure 97: Pushrod adjustment.....	375
Figure 98: Fire resistant sleeving installation.....	376

## **WARNINGS, CAUTIONS AND NOTES**

---

The following definitions apply to warnings, cautions and notes as used in this aircraft maintenance manual:

**WARNING**

Indicates an action necessary to prevent injury or death.

**CAUTION**

Indicates an action necessary to prevent damage to the aircraft, aircraft parts or property.

**NOTE**

Provides valuable additional information.

# SECTION 1

## GENERAL

This section provides general information, capacities and general procedures and specifications.

### 1. GENERAL

#### 1.1. DESCRIPTION

The Airplane Factory Sling 2 and SLING LSA are two seat, single engine, tricycle fixed undercarriage aluminum aircraft with conventional low wing design.

## 1.2. AIRCRAFT SPECIFICATIONS AND DATA

### 1.2.1 AIRCRAFT 3-VIEW DRAWING

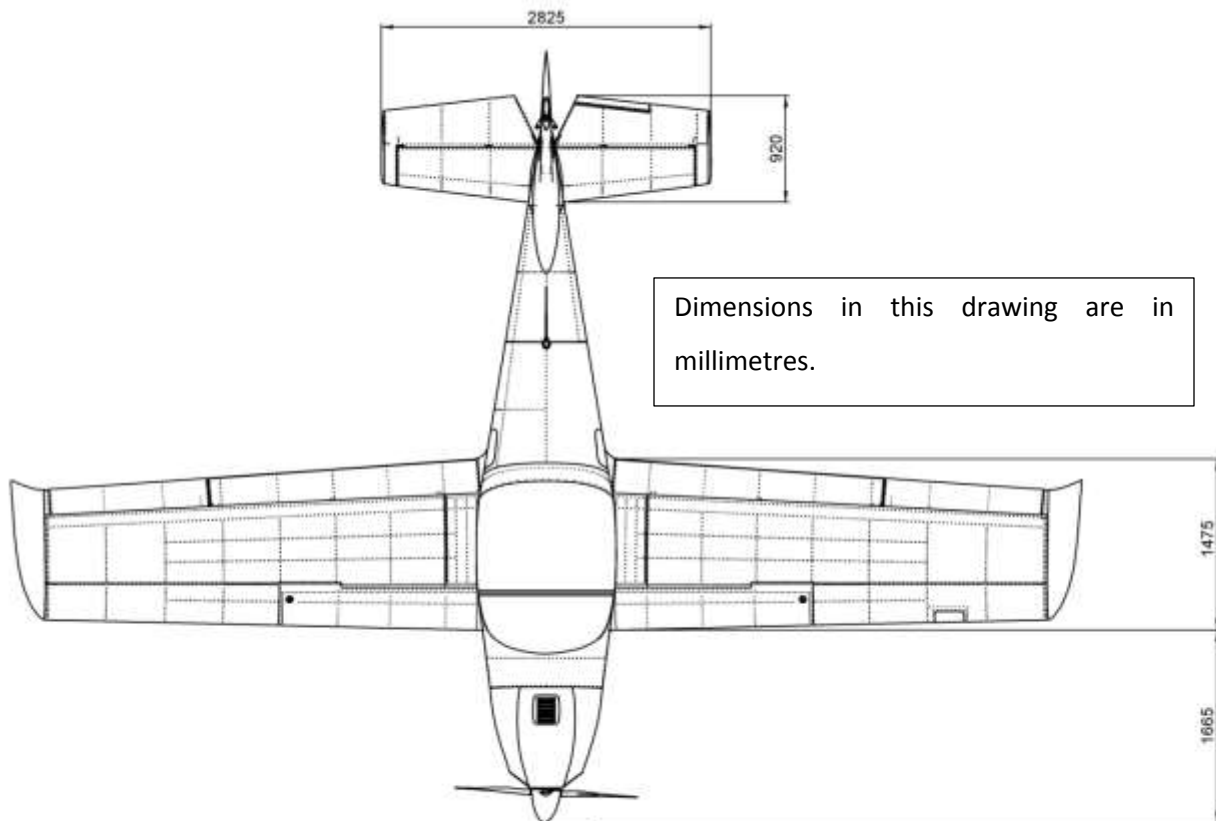

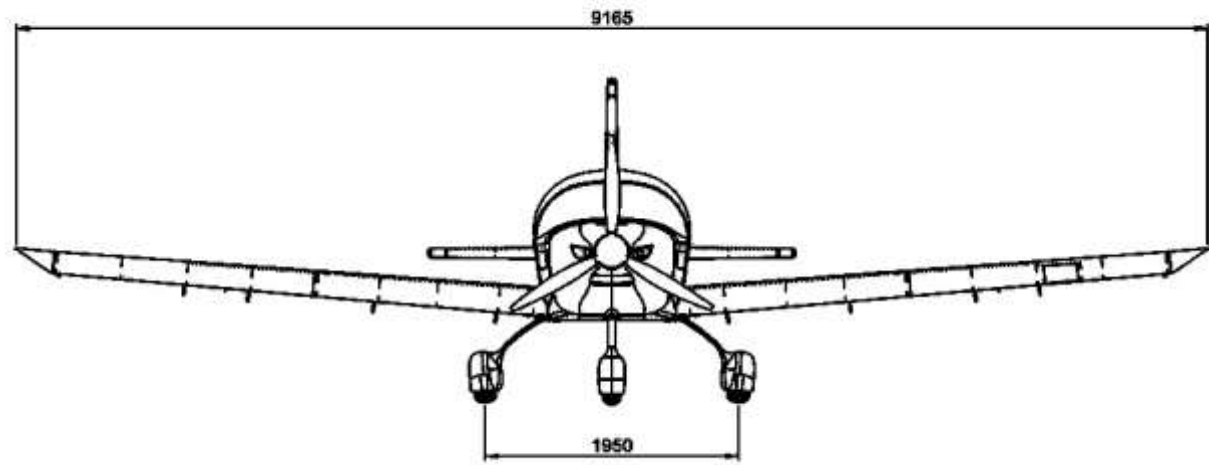
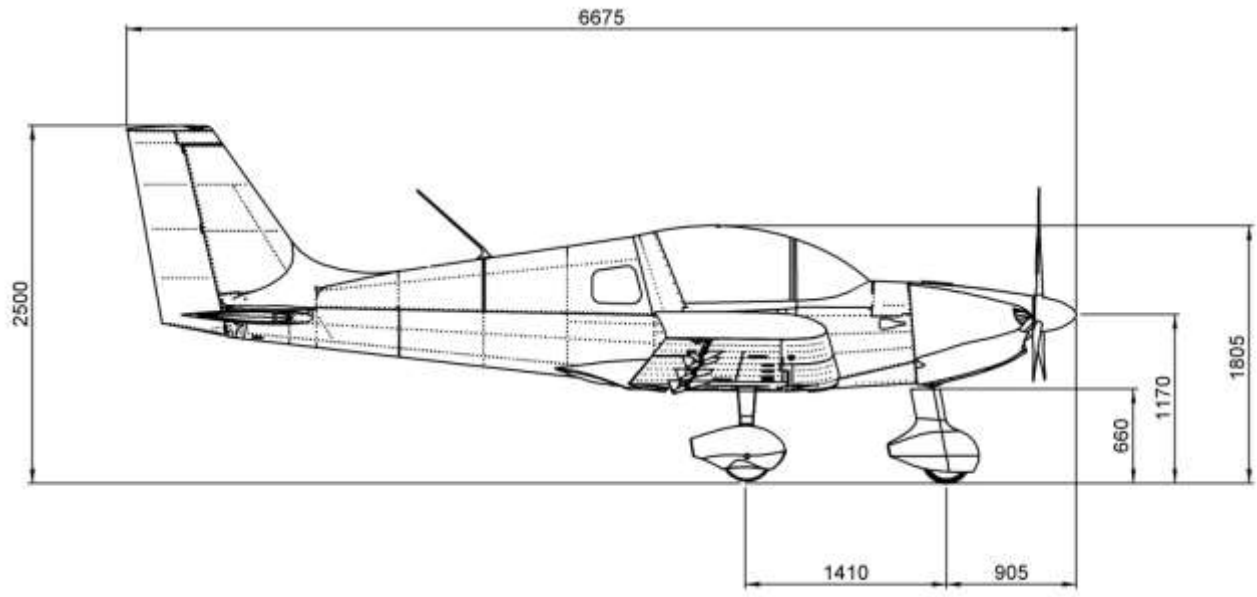

Dimensions in this drawing are in millimetres.

## 1.2.2 AIRCRAFT GEOMETRIC DIMENSIONS

### WING

Span:	9 165 mm / 30 ft.
Area (gross):	11.845 m <sup>2</sup> / 127.5 ft <sup>2</sup> .
Aspect ratio:	7.04.
Dihedral:	5°
Tip washout:	2°

### HORIZONTAL STABILIZER

Span:	2 825 mm / 9.268 ft.
-------	----------------------

### VERTICAL STABILIZER

Span:	1 470 mm / 4.823 ft.
-------	----------------------



## FUSELAGE

Length:	5 770 mm / 18.93 ft.
Width (cockpit):	1 120 mm / 3.675 ft.
Total aircraft length:	6 675 mm / 21.899 ft.
Height overall :	2 500 mm / 8.202 ft.

## LANDING GEAR

Wheel track:	1 950 mm / 6.4 ft.
Wheel base:	1 410 mm / 4.63 ft.

### 1.2.3 AIRCRAFT WEIGHTS

#### MAXIMUM WEIGHTS

Maximum take-off weight:	700 kg / 1543.24 lb (Sling 2). 600 kg / 1323 lb (Sling LSA).
Maximum landing weight:	700 kg / 1543.24 lb (Sling 2). 600 kg / 1323 lb (Sling LSA).
Maximum total baggage weight:	35 kg / 77 lb (Sling 2).
Front luggage compartment section maximum:	35 kg / 77 lb (Sling 2).
Rear luggage compartment section maximum:	25 kg / 55 lb (Sling 2).
Maximum total baggage weight:	15 kg / 33 lb (Sling LSA).
Front luggage compartment section maximum:	15 kg / 33 lb (Sling LSA).
Rear luggage compartment section maximum:	15 kg / 33 lb (Sling LSA).

#### STANDARD WEIGHTS

Standard empty weight:	370 kg / 815.71 lb.
Maximum useful load:	330 kg / 727.53 lb.

NOTE: Standard weights are estimates based on standard equipment.

### 1.3. ENGINE

The Sling 2 and Sling LSA aircraft are fitted with one of the following engines:

#### 914 UL (SLING 2 ONLY)

Manufacturer: Bombardier-Rotax GmbH.  
Model: 914 UL.  
Type: Four stroke, turbocharged, four cylinder horizontally opposed, 1211.2 cm<sup>3</sup> (73.91 inch<sup>3</sup>) displacement, automatic waste gate control, mixed cooling (water-cooled heads and air-cooled cylinders), dry sump forced lubrication with separate oil tank, twin carburetors, two electrical fuel pumps, dual electronic ignition and integrated reduction gearbox with torque damper.  
Maximum power: 85.76 kW (115 hp) at 5 800 rpm (maximum 5 minutes).  
74.57 kW (100 hp) at 5 500 rpm (continuous).

Refer to the latest revision of the Rotax 914 UL technical documentation (e.g. operator and maintenance manuals), as available from the manufacturer, for comprehensive technical data on the engine.

#### 912 ULS (SLING 2, SLING LSA)

Manufacturer: Bombardier-Rotax GmbH.  
Model: 912 ULS.  
Type: Four stroke, four cylinder horizontally opposed, 1392 cm<sup>3</sup> (82.6 inch<sup>3</sup>) displacement, mixed cooling (water-cooled heads and air-cooled cylinders), dry sump forced lubrication with separate oil tank, twin carburetors, mechanical (engine driven) fuel pump, electrical fuel pump, dual electronic ignition and integrated reduction gearbox with torque damper.  
Maximum power: 73.5 kW (100 hp) at 5 800 rpm (maximum 5 minutes).  
69 kW (92.53 hp) at 5 500 rpm (continuous).

Refer to the latest revision of the Rotax 912 ULS technical documentation (e.g. operator and maintenance manuals), as available from the manufacturer, for comprehensive technical data on the engine.

**912 iS (SLING 2, SLING LSA)**

Manufacturer: Bombardier-Rotax GmbH.  
Model: 912 iS.  
Type: Four stroke, four cylinder horizontally opposed, 1392 cm<sup>3</sup> (82.6 inch<sup>3</sup>) displacement, mixed cooling (water-cooled heads and air-cooled cylinders), redundant electric fuel injection, engine management system, two electrical fuel pumps and integrated reduction gearbox with torque damper.  
Maximum power: 73.5 kW (100 hp) at 5 800 rpm (maximum 5 minutes).  
69 kW (92.53 hp) at 5 500 rpm (continuous).

Refer to the latest revision of the Rotax 912 iS technical documentation (e.g. operator and maintenance manuals), as available from the manufacturer, for comprehensive technical data on the engine.

#### 1.4. APPROVED SUBSTANCES, FLUIDS, LUBRICANTS AND CAPACITIES

It is recommended to refer to and comply with the latest Rotax 912 ULS / 912 iS / 914 UL engine operator and / or maintenance manuals, as applicable, and with service instructions (as issued from time to time), with regard to recommended lubricants, coolant fluids and fuels, and their usage. Any reference to lubricants, coolant fluids and fuels appearing in this manual is as a general recommendation only.

Refer to the latest revision of Rotax service instructions SI-912i-001, SI 912-016 and SI-914-019, as applicable, for recommendations regarding engine operating fluids.

<b>FUEL 912 ULS / 914 ENGINE</b>			
<b>Minimum RON 95 / Minimum AKI 91</b>			
<b>Grade</b>	<b>MOGAS</b>		DIN EN 228 Super, DIN EN 228 Super Plus, ASTM D4814.
	<b>AVGAS</b>	<b>Leaded</b>	AVGAS 100LL ASTM D910.
		<b>Unleaded</b>	UL91 ASTM D7547.
<b>Capacity (Sling 2)</b>	150 litres / 39.626 US gallons (75 litres / 19.813 US gallons per tank).		
<b>Total usable fuel (Sling 2)</b>	146 litres / 38.569 US gallons (73 litres / 19.285 US gallons per tank).		
<b>Capacity (Sling LSA)</b>	75 litres / 19.813 US gallons.		
<b>Total usable fuel (Sling LSA)</b>	73 litres / 19.285 US gallons.		

<b>FUEL 912 iS ENGINE</b>			
<b>Minimum RON 95 / Minimum AKI 91</b>			
<b>Grade</b>	<b>MOGAS</b>		DIN EN 228 Super, DIN EN 228 Super Plus.
	<b>AVGAS</b>	<b>Leaded</b>	AVGAS 100LL ASTM D910.
<b>Capacity (Sling 2)</b>	150 litres / 39.626 US gallons (75 litres / 19.813 US gallons per tank).		
<b>Total usable fuel (Sling 2)</b>	146 litres / 38.569 US gallons (73 litres / 19.285 US gallons per tank).		
<b>Capacity (Sling LSA)</b>	75 litres / 19.813 US gallons (The port fuel tank feed line is blanked off, rendering the port tank unusable. With the feed line re-established, the total fuel capacity will be the same as for the Sling 2).		
<b>Total usable fuel (Sling LSA)</b>	73 litres / 19.285 US gallons. gallons (The port fuel tank feed line is blanked off, rendering the port tank unusable. With the feed line re-established, the total usable will be the same as for the Sling 2).		

NOTE: AVGAS 100LL places greater stress on the valve seats due to its lead content and forms increased deposits in the combustion chamber and lead sediments in the oil system. Thus it should only be used in case of problems with vapour lock and when other types of gasoline are unavailable.

<b>ENGINE OIL</b>	
<b>Grade</b>	Automotive grade API SG (or higher) type oil, preferably synthetic or semi-synthetic. When operating on unleaded fuels or MOGAS fully synthetic oil is recommended.
<b>Oil capacity</b>	3.5 litres (7.4 pints).

<b>COOLANT 912 ULS / 914 UL ENGINE</b>		
<b>Grade / type</b>	Water-free propylene glycol based coolant concentrate.	<b>DO NOT MIX THESE TWO TYPES OF COOLANT.</b>
	1:1 Ethylene glycol based coolant and distilled water mixture.	
<b>Cooling capacity</b>	3 litres (6.34 pints).	

<b>COOLANT 912 iS ENGINE</b>		
<b>Grade / type</b>	1:1 Ethylene glycol based coolant and distilled water mixture.	<b>DO NOT USE WATER FREE COOLANT.</b>
<b>Cooling capacity</b>	3 litres (6.34 pints).	

<b>BRAKE FLUID</b>	
<b>Grade / type</b>	Automatic Transmission Fluid (ATF).

<b>AIR FILTER OIL</b>	
<b>Type</b>	K&N filter oil spray or K&N filter oil.

<b>GLUE</b>	
<b>REPAIR OF FUEL LEAKS</b>	
<b>Type</b>	AMSS8802 Class B-2 compliant sealant (e.g. (as used by The Airplane Factory) FLAMEMASTER CS 3204 Class B-2 fuel tank sealant, Parts A and B. Mix parts according to manufacturer instructions).
<b>SECURING BRAKE FLUID LINE(S) TO MAIN UNDERCARRIAGE STRUT(S)</b>	
<b>Type</b>	PRATLEY QUICKSET CLEAR.

<b>MAIN WHEEL BEARING CLEANING SOLVENT</b>	
<b>Type</b>	Paraffin.

<b>CANOPY / WINDSHIELD CLEANING FLUIDS / POLISH</b>	
<b>Type</b>	Suitable for polymethyl methacrylate (Perspex / Plexiglass). Never use gasoline, alcohol, alcohol based products or chemical solvents.

<b>LUBRICANTS / GREASE</b>	
<b>Canopy Bearings</b>	MIL-G-3278 type grease or equivalent.
<b>Canopy latches</b>	Q20 or equivalent.
<b>Rudder and pedal control cable terminals</b>	MIL-G-3278 type grease or equivalent.
<b>Rudder cable guides</b>	Q20 or equivalent.
<b>Elevator pushrod (in centre) guide</b>	MIL-G-3278 type grease or equivalent.
<b>Elevator torque tube bushes</b>	Q20 or equivalent.
<b>Trim tab hinge</b>	Q20 or equivalent.
<b>Aileron pushrod guide (in the centre of wing)</b>	MIL-G-3278 type grease or equivalent.
<b>Flap torque tube supports</b>	Q20 or equivalent.
<b>Flap actuator ends</b>	MIL-G-3278 type grease or equivalent.
<b>Rudder pedal bushes</b>	Q20 or equivalent.
<b>Control sticks</b>	MIL-G-3278 type grease or equivalent.
<b>Control stick torque tube bushes</b>	Q20 or equivalent.
<b>Nose gear support blocks</b>	MIL-G-3278 type grease or equivalent.
<b>Main wheel bearings</b>	MIL-G- 81322 type grease or equivalent (e.g. Aeroshell 22).
<b>Propeller (Airmaster propeller)</b>	Refer to the <u>latest revision</u> of the propeller operator's manual.
<b>Engine</b>	Refer to the <u>latest revision</u> of the Rotax 912 ULS / 912 iS / 914 UL engine operator's manual and / or maintenance manuals, as applicable.

<b>THREAD LOCKING SEALANT</b>	
<b>Loctite 222</b>	<p>Inspection panel screws, elevator trim motor installation screws.</p> <p>Propeller extension (bolts securing propeller hub / assembly to the propeller extension (Airmaster propeller))</p> <p>VHF antenna retaining screws, instrument panel retaining screws.</p> <p>Navigation light retaining screws.</p> <p>Strobe light retaining screws.</p> <p>Fuselage fairings.</p> <p>Fuel selector valve retaining screws.</p>
<b>Loctite 243</b>	<p>Aileron and elevator servo mounting screws.</p> <p>Propeller extension (bolts securing propeller extension to engine flange).</p> <p>Bolt securing main wheel fairing to main axle spacer.</p>
<b>Loctite 557</b>	<p>Fuel hose and oil pipe fitting threads.</p> <p>Brake line fittings.</p>



**1.5. FASTENER TORQUE VALUES AND WRENCH SIZE(S)**

**1.5.1 GENERAL**

Use these values unless indicated otherwise.

AN BOLT SIZE	THREAD SIZE	STANDARD NUTS		WRENCH SIZE
		AN310, AN315,MS20365 (AN365)		
		Nm	ft.lb	
AN3	10-32	2.0 to 2.7	1.475 to 1.991	3/8 "
AN4	1/4-28	5.7 to 7.9	4.2 to 5.827	7/16 "
AN5	5/16-24	11.2 to 15.7	8.3 to 11.6	1/2 "
AN6	3/8-24	18.0 to 21.4	13.3 to 15.8	9/16 "

NOTE: Torque values in above table are for dry (not oiled) threads.

**1.5.2 SPECIFIC**

ITEM	TORQUE VALUE		
	Nm	ft.lb	
Wing mounting bolts (front) (AN6).	30	22.127	
Wing mounting bolts (front and rear) (AN5).	18	13.276	
Main spar bolts (AN4).	7	5.163	
Main landing gear mounting bolts (M10).	25	18.44	
Propeller mounting bolts - propeller extension to engine flange (M8).	24	17.701	
Propeller mounting bolts - propeller hub to propeller extension (M8).	20	14.751	Airmaster 332 propeller.
Propeller mounting bolts - propeller hub to propeller extension.	20	14.751	Warp Drive propeller.
Propeller mounting bolts - propeller hub to propeller extension.	19	14.014	Whirlwind propeller.
Engine mounting bolts (securing engine suspension frame to engine mount) (M10).	38	28.027	
NOTE: Torque value for these bolts is with oiled thread.			
Engine mount mounting bolts (securing engine mount to engine firewall) (AN5).	16	11.801	

**1.6. EQUIPMENT LIST**

<b>AVIONICS / ENGINE INSTRUMENTS</b>
<p>MGL Challenger iEFIS incorporating:</p> <p>Moving Map GPS, GLS, Autopilot Operating System, Artificial Horizon, Airspeed Indicator, Altimeter, Vertical Speed Indicator, Angle of Attack Indicator, Compass, Tachometer, Oil Pressure, Fuel Pressure, Fuel Flow, Oil Temperature, Cylinder Head Temperature (x2), Exhaust Gas Temperature (x4), Hour Meter, Fuel Quantity, Volt Meter, Trim Indicator, Flap Indicator, G Meter, Artificial Horizon, Turn and Slip indicators, Time, Flight Time, Time Since Start-up, Range, Endurance.</p> <p>MGL V6 Panel Mount Transceiver (with integral intercom).</p> <p>Magnetic (Standard) Compass.</p> <p>2 1/4 inch Ball Type Slip Indicator.</p> <p>3 1/8 inch Altimeter (analogue) and Airspeed Indicator (analogue).</p>
<b>WARNING LIGHTS AND INDICATORS</b>
Alternator Charge Warning Light, MGL EFIS Warning Light, 2 xTurbocharger Warning Lights (914 UL).
<b>CONTROLS</b>
Dual Control Sticks, Dual Rudder Pedals, Centre Position Throttle, Engine Choke (914 UL / 912 ULS) Electric Flaps, Electric Elevator Trim, Centre Position Brake Lever, Hydraulic Disc Brakes, Parking Brake, Fuel Selector Valve, Direct Nose Wheel Steering.
<b>EXTRAS AND SAFETY EQUIPMENT</b>
Ballistic Recovery System (Parachute), Fire Extinguisher.
<b>INTERIOR</b>
Adjustable Pilot and Co-pilot Seats, Adjustable Rudder Pedals, Adjustable Cabin Air Ventilators and Heater, 12 V Power Outlet, Anodized Aluminium Instrument Panel.
<b>EXTERIOR</b>
All Aluminium Structure, Landing Light (Each Wing), Taxi Light (Each Wing), Strobe Light, Navigation Lights, Fixed Landing Gear (Steerable Nose Wheel), Nose and Main Wheel Fairings.
<b>POWER PLANT AND ACCESSORIES</b>
Rotax 912 ULS / 912 iS / 914 (Sling 2) Engine and Airmaster 332 Variable Pitch Propeller / Whirlwind Ground Adjustable Propeller / Warp Drive Ground Adjustable Propeller.

**1.7. SPECIFICATION AND PRESSURES**

<b>WHEEL</b>	<b>TYPE</b>	<b>PRESSURE</b>
Main wheel (s)	15.00 x 6.00-6 (6-ply)	2.2 bar (31.9 psi)
Nose wheel	5.00-5 (6-ply)	1.8 bar (26.1 psi)

**1.8. GROUND HANDLING**

**WARNING**  
**MASTER / IGNITION SWITCHES OFF.**

**CAUTION**  
**AS A GENERAL RULE, APPLY FORCE TO AIRCRAFT STRUCTURE ONLY ON MAIN  
STRUCTURAL ELEMENTS SUCH AS FRAMES OR SPARS.**

Move the aircraft on ground by pulling on the propeller blades, close to hub. A specially made tow bar can be attached to the nose wheel axle ends. The aircraft can be steered using the rudder pedals (with a capable person in the cockpit), or, for sharp turns, by lowering the tail to raise the nose wheel off the ground. In this case press down on the rear upper fuselage and horizontal stabiliser (place your hands above the main spar, where the rivets are). Avoid dragging the nose wheel sideways. Do not attempt to counter any movement of the aircraft by handling it by its wing tips.

### 1.9. PARKING AND TIE DOWN

It is recommended that chocks are used when parking outdoors or in a hanger. If chocks are not available, use the park brake. If possible, park the airplane facing into the wind. Tie down (to ground anchors) at the outer wing (1) and rear fuselage (2) tie down points. Aircraft tie-down is essential in severe weather and high wind conditions. In such conditions it is also preferable to tie down the nose wheel from the engine mount near the nose wheel strut attachment point.



### 1.10. JACKING

**WARNING**

**A LIFTED AIRCRAFT MUST BE SECURELY SUPPORTED BY STATIC STANDS (OTHER THAN A / THE JACKING DEVICE). THE AIRCRAFT MAY NOT MOVE FROM AN ATTEMPT TO SHAKE IT HORIZONTALLY OR VERTICALLY.**

Following removal of the main wheel fairings (refer to paragraph 4.4.1.1), the aircraft can be jacked from under the ends of the main wheel struts, just inside of the wheels. Ensure that steps are taken to locate the jack sturdily under the bottom edge of the wheel strut, so as to prevent slippage.

If it is necessary to lift the nose gear, the engine cowling should be removed and the aircraft lifted using the engine mount as the attachment point. The nose wheel can also easily be lifted by pressing down on the rear fuselage (ordinarily on the dorsal fin) and the horizontal stabiliser above the main spar.

**1.11. AIRCRAFT LEVELLING**

Occasional levelling of the aircraft may be necessary to ensure proper wing incidence and / or dihedral or for exact centre of gravity determination.

**1.11.1 LONGITUDINAL LEVELLING**

TOOLS / EQUIPMENT REQUIRED		
ITEM	QUANTITY	NOTES
1	Shims.	As needed.
2	Spirit, water or electronic level.	1
The above list is not necessarily a complete list of all required tools and equipment needed. A calibrated torque wrench (with adequate range) and the correct size (as implied by the above tool list) accessories (sockets etc.) are implied for torquing bolts / nuts, if applicable. Refer to paragraph 1.5 for torque values.		
AUTHORISED PERSONNEL		
Any person performing maintenance of any kind on the aircraft or any component thereof must do so in accordance with national legislation. This is the responsibility of the aircraft owner and any person who is to perform any maintenance on the aircraft.		

## PROCEDURE

1. Open the canopy.
2. Place a spirit, water or electronic level on the top of the canopy slider frames adjacent to the pilot or passenger seat.

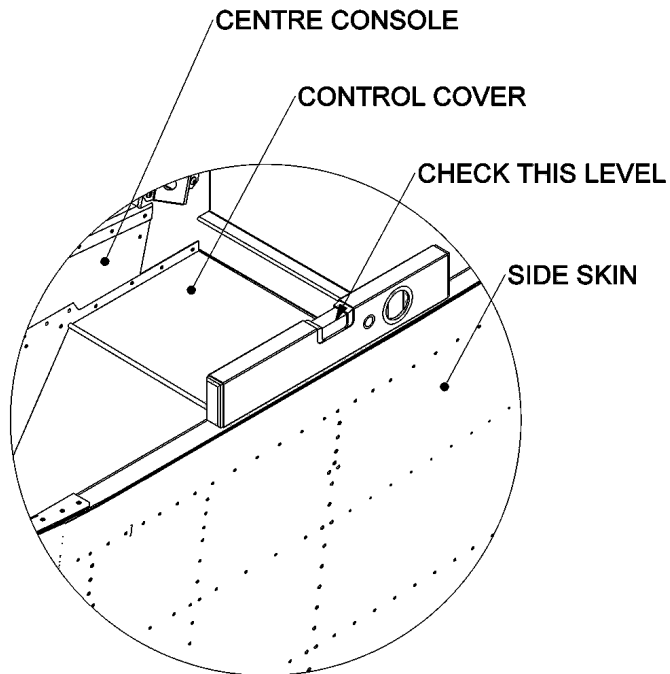

Figure 1: Longitudinal leveling reference position.

3. Adjust the aircraft's tilt through shims placed under wheels or by regulating tyre pressure.

**1.11.2 TRANSVERSE LEVELLING**

TOOLS / EQUIPMENT REQUIRED		
ITEM	QUANTITY	NOTES
1	Shims	As needed.
1	Spirit, water or electronic level	1
<p>The above list is not necessarily a complete list of all required tools and equipment needed. A calibrated torque wrench (with adequate range) and the correct size (as implied by the above tool list) accessories (sockets etc.) are implied for torquing bolts / nuts, if applicable. Refer to paragraph 1.5 for torque values.</p>		
AUTHORISED PERSONNEL		
<p>Any person performing maintenance of any kind on the aircraft or any component thereof must do so in accordance with national legislation. This is the responsibility of the aircraft owner and any person who is to perform any maintenance on the aircraft.</p>		

## PROCEDURE

1. Open the canopy.
2. Remove a front seat (refer to paragraph 4.3.2.1).
3. Place a spirit, water or electronic level across the top of the centre carry through spar, from one side to the other, and at right angles to the longitudinal axis of the aircraft.

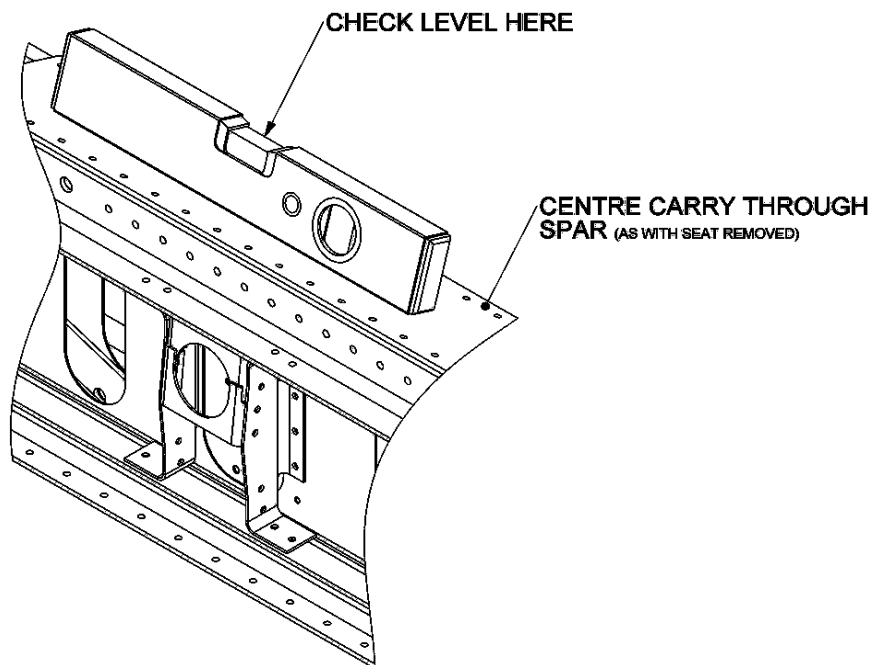

Figure 2: Transverse leveling reference position.

4. Adjust the aircraft's tilt through shims placed under wheels or by regulating tyre pressure.



## 1.12. AIRCRAFT ALIGNMENT

The aim of the alignment control is mainly to compare the measures taken on both sides and to check if the difference between them, if any, is within the tolerances reported below.

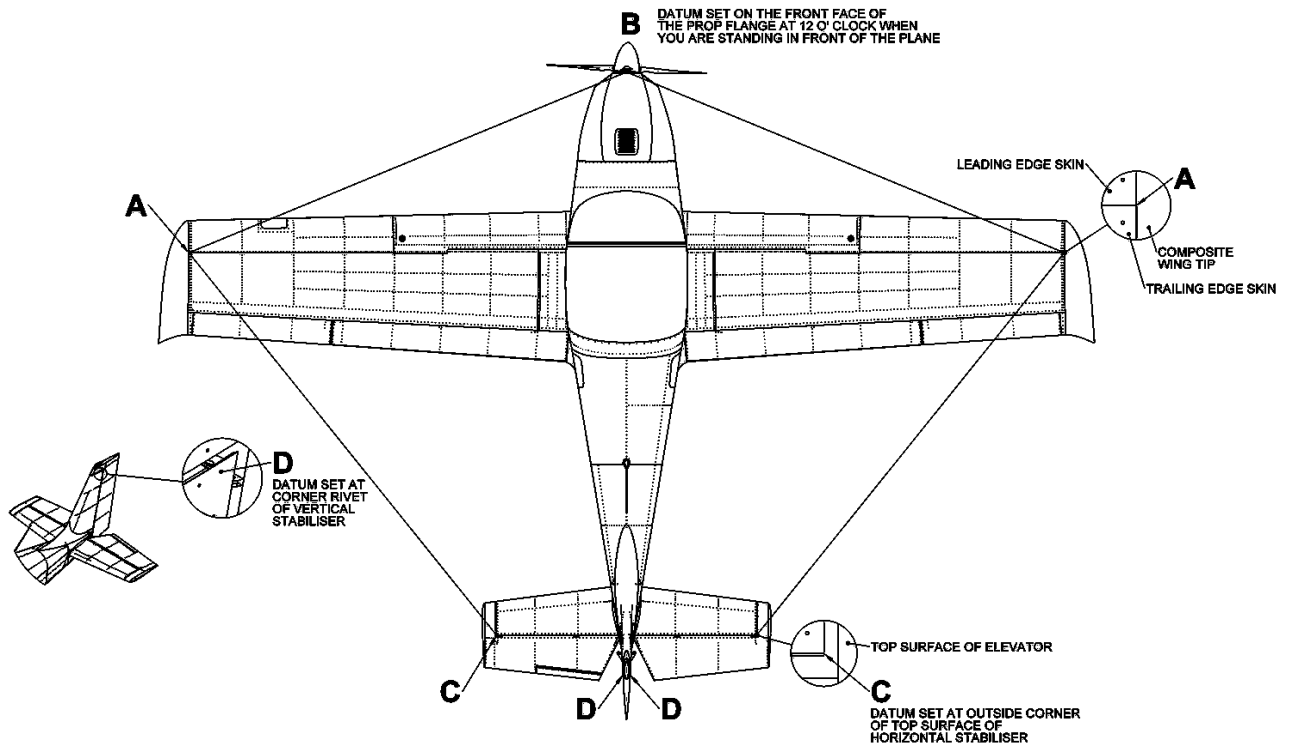

Datum	Nominal distances (mm)
A – B	4 617 mm (±20 mm) / 181.772 inches (±0.787 inches)
A – C	4 845 mm (±20 mm) / 190.748 inches (±0.787 inches)
C – D	1 696 mm (±20 mm) / 66.7717 inches (±0.787 inches)

Figure 3: Aircraft alignment.

### DATUMS

A, E – On the wing upper surface, the outside edge of the wing skins where the trailing edge of the leading edge skin overlays the trailing edge skin.

- B – The 12 o'clock position on the front face of the engine's propeller flange (i.e. the top of the front face of the engine's propeller flange). To get access it is necessary to remove the engine upper cowling (refer to paragraph 5.1.1).
- C – On the outside rear corner of the horizontal stabilizer upper skin.
- D – The upper / aft rivet on the vertical stabilizer skin. It is the highest rivet shared between the skin and the vertical stabilizer rear spar flanges.

**1.13. CONTROL SURFACE DEFLECTION / TRAVEL**

CONTROL SURFACE	REFERENCE	DEFLECTION		TOLERANCE
		UP / LEFT	DOWN / RIGHT	
Ailerons	Starting from the tips lined up with the wing tips.	22°	22°	± 3°
Elevator	Starting from the horn lined up with the leading edge.	28°	20°	± 2°
Trim tab	Starting flush with elevator	5°	25°	± 3°
Rudder		25°	25°	± 2°
Flaps (maximum travel)		0°	30°	± 3°

**1.14. RUDDER CONTROL CABLE TENSION**

Tension (with rudder straight)	15 N ±3 N (1.5 kg ±0.3 kg) / 3.372 lb-force ±0.674 lb-force
--------------------------------	---

**1.15. AIRCRAFT RIGGING**

**1.15.1 RUDDER CABLE TENSION ADJUSTMENT**

Refer to paragraph 4.2.2.5.

**1.15.2 ELEVATOR ADJUSTMENT**

Refer to paragraph 4.2.1.5.

**1.15.3 ELEVATOR TRIM TAB ADJUSTMENT**

Refer to paragraph 4.2.1.6.

**1.15.4 AILERON ADJUSTMENT**

Refer to paragraph 4.1.2.3.

**1.15.5 FLAP ADJUSTMENT**

Refer to paragraph 4.1.3.3.

## 1.16. WEIGHT AND BALANCE INFORMATION

### 1.16.1 REQUIREMENT / SCHEDULE

Weight and balance measurements need to be performed according to the following schedule:

- Upon completion of manufacture and before the first flight.
- Whenever new equipment is fitted or a modification is done which influences the weight of the aircraft.
- Periodically as may be required by national legislation.

### 1.16.2 MOMENT ARMS

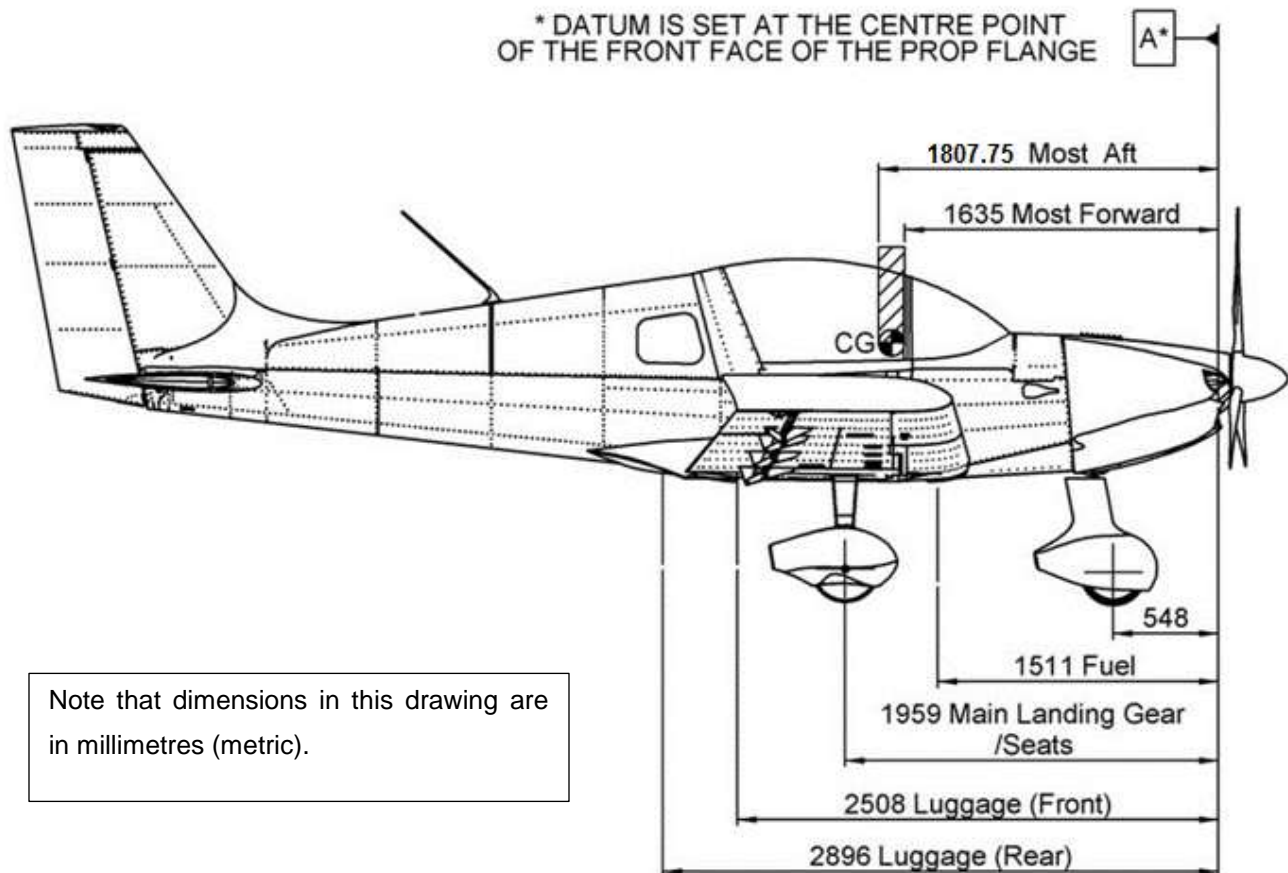

Figure 4: Moment arms.

**1.16.3 CENTRE OF GRAVITY FORMULAE**

$$\text{Aircraft CG} = \frac{\text{Total moment arm}}{\text{Total Weight}}$$

$$\%MAC = (\text{CG} - 1366 \text{ mm}) \times \frac{100}{1339 \text{ mm}} \quad (\text{metric})$$

$$\%MAC = (\text{CG} - 53.78 \text{ ") } \times \frac{100}{52.72 \text{ "}} \quad (\text{imperial})$$

**1.16.4 EMPTY WEIGHT CENTRE OF GRAVITY TABLE**

	ITEM	WEIGHT [kg] / [lb]	ARM [mm] / [inch]	MOMENT [weight x arm]
<b>AIRCRAFT EMPTY CG</b>	Right Main Wheel	$W_R =$	$L_R = 1\,959 \text{ mm} / 77.126 \text{ "}$	
	Left Main Wheel	$W_L =$	$L_L = 1\,959 \text{ mm} / 77.126 \text{ "}$	
	Nose Wheel	$W_N =$	$L_N = 548 \text{ mm} / 21.575 \text{ "}$	
	Computed empty Centre of gravity	Empty weight: $W_E = \dots\dots\dots \text{kg} / \text{lb}$	$\text{CG} = \dots\dots\dots \text{mm} / \text{inch}$ ( $\dots\dots\dots\% \text{..MAC}$ )	Aircraft moment :

**1.16.5 EMPTY WEIGHT CENTRE OF GRAVITY DETERMINATION**

TOOLS / EQUIPMENT REQUIRED			
ITEM		QUANTITY	NOTES
1	Calibrated scales, minimum 250 kg (551 lb) capacity.	3	
2	Calibrated scale, minimum 250 kg (551 lb) capacity.	1	Alternative to item 1
3	Blocks with same height as scales (able to bear aircraft weight).	2	
4	Calculator.	1	
<p>The above list is not necessarily a complete list of all required tools and equipment needed. A calibrated torque wrench (with adequate range) and the correct size (as implied by the above tool list) accessories (sockets etc.) are implied for torquing bolts / nuts, if applicable. Refer to paragraph 1.5 for torque values.</p>			
AUTHORISED PERSONNEL			
<p>Any person performing maintenance of any kind on the aircraft or any component thereof must do so in accordance with national legislation. This is the responsibility of the aircraft owner and any person who is to perform any maintenance on the aircraft.</p>			

## PROCEDURE

1. Carry out weighing procedure inside a closed building, so as to exclude influence from wind.
2. Remove any unnecessary objects (inadvertently) left on board aircraft.
3. Ensure that all legally required paperwork is on board (e.g. POH, ATF, etc.).
4. Drain fuel.
5. Align nose wheel.
6. Make sure that the engine oil, hydraulic fluids and coolants are at operating levels.
7. Adjust seats to the rearmost position(s).
8. Flaps retracted ( $0^\circ$ ).
9. Ailerons in neutral position, elevator in down position.
10. The aircraft must be weighed in a level attitude.
11. Position the scales under each tyre, or a scale under one tyre and blocks under the remaining tyres.
12. In the case where one scale and two blocks are used, the scale needs to be alternated between/ under the wheels.
13. Record the weights from the individual scales (wheels) in the table in paragraph 1.16.4.
14. Calculate the moment for each wheel and record in the table in paragraph 1.16.4.
15. Calculate the total empty weight and record in the table in paragraph 1.16.4.
16. Calculate the total aircraft moment and record in the table in paragraph 1.16.4.
17. Use the information recorded in the table in paragraph 1.16.4 and the formulae listed in paragraph 1.16.3 to calculate the empty weight centre of gravity.



## 1.17. AIRCRAFT STORAGE

### 1.17.1 SHORT TERM STORAGE

Refer to and comply with any storage instructions as stipulated by the latest revision of the Rotax 912 ULS / 912 iS / 914 UL engine operator, installation and maintenance manuals, as applicable.

If the aircraft is to be stored outside, follow the guidelines outlined in paragraph 1.17.3.

### 1.17.2 MEDIUM TO LONG TERM STORAGE

Refer to and comply with any storage instructions as stipulated by the latest revision of the Rotax 912 ULS / 912 iS / 914 UL engine operator, installation and maintenance manuals, as applicable.

- If the aircraft is to be stored outside, follow the guidelines outlined in paragraph 1.17.3.
- Remove the fuel completely from the tanks, lines and carburettor bowls. Ethanol based fuel should not be stored in the tanks or carburettors for extended periods.
- Clean the aircraft thoroughly.
- Clean any oil or grease from tyres and coat tyres with a tyre preservative. Cover tires to protect against grease and oil.
- Rotate the wheels approximately every 30 days to prevent the formation of flat spots.
- Seal or cover all openings which could allow moisture and / or dust to enter.
- Remove the battery (refer to paragraph 10.1). Store the battery in a safe, cool and dry location. Charge the battery as needed, according to the battery manufacture's instructions / recommendations.
- Seal all engine openings exposed to the atmosphere with suitable covers or non-hygroscopic tape. Attach a red warning flag at each point where a cover or tape is fitted., to act as a reminder.

### 1.17.3 OUTSIDE STORAGE

Refer to and comply with any storage instructions as stipulated by the latest revision of the Rotax 912 ULS / 912 iS / 914 UL engine operator, installation and maintenance manuals, as applicable.

- Tie-down the aircraft in accordance with paragraph 1.9.
- Install protective covers on the pitot tube, static vents (if separate from pitot tube), air vents, openings in the engine cowling and any applicable openings in fuselage. This is important as it prevents the ingress of rain, dust and foreign material.
- It is advisable that a tarpaulin (properly attached) is fitted to the aircraft.

### 1.17.4 RETURNING THE AIRCRAFT TO SERVICE

Refer to and comply with any relevant instructions as stipulated by the latest revision of the Rotax 912 ULS / 912 iS / 914 UL engine operator, installation and maintenance manuals, as applicable.

- Inspect tyres for proper inflation (refer to paragraph 1.7).
- Inspect battery for general condition and charge. If necessary charge the battery according to the battery manufacturer's instructions / recommendations.
- Install the battery (if it was removed).
- Verify that the oil sump has the proper quantity of engine oil (refer to pilot operating handbook, the Rotax 912 ULS / 912 iS / 914 UL operator manual and / or maintenance manuals, as applicable, for instructions).
- Verify correct engine coolant levels.
- Inspect air filter and clean if necessary.
- Remove the materials used to cover openings.
- Perform a thorough pre-flight inspection.
- Start and warm-up the engine. Verify engine readings to be within limits.

## 1.18. CORROSION PREVENTION

The information supplied here is as a general guideline only, and is by no means intended to be exhaustive, complete or authoritative. For more in depth information refer to an applicable and authoritative publication, such as the FAA Advisory Circular AC43.13-1B: Acceptable Methods, Techniques and Practices - Aircraft Inspection and Repair.

It is highly advisable that expert advice be sought with regard to corrosion related issues.

6061-T6 Aluminium (of which the aircraft is constructed) is reasonably corrosion resistant and accordingly is unlikely to corrode substantially.

It is important to keep the aircraft clean and to remove any collection of corrosive causing agents such as water, anti-freeze, oil, grease, dregs and other foreign matter. To avoid damage to the finish, do not use polishing detergents. Original or equivalent corrosion prevention, if used, must be re-applied after any alteration or repair. If any trace of corrosion is detected it should be removed as soon as possible and the applicable part should be treated immediately to prevent further corrosion.

Treatment consists of mechanically removing as much as possible of any corrosion by-products, applying corrosion inhibitor and replacing any original finish.

### STRUCTURES

- **STEEL PARTS:**

With the exception of highly stressed components or with stainless steel components, it is possible to use abrasives, steel brushes (if operated manually) and steel wool.

- **ALUMINIUM PARTS:**

Steel wool, emery cloth or steel wire brushes (unless stainless steel), copper alloy brushes, rotary wire brushes along with other highly abrasive material should not be used. Steel or emery particles become embedded in the softer material causing corrosion.

Accurate brushing with a sturdy fibre brush should get rid most of the corrosion and ensures that the anti-corrosion agent penetrates completely into the cracks.

After cleaning surface corrosion, parts must be treated with an anti-corrosion finish consisting of a 4 litre solution of water, 10% chromic acid and 20 drops of battery electrolyte. Leave the chromic acid solution on the part for at least five minutes and then remove the excess with water or a damp cloth. Apply protective finish the same day in which treatment begins.

### 1.19. SOURCES FOR THE PURCHASING OF PARTS

Spare parts can be ordered from the Airplane Factory at [www.airplanefactory.co.za](http://www.airplanefactory.co.za), or from your local dealer.

### 1.20. DISPOSABLE REPLACEMENT PARTS

ITEM	DESCRIPTION	PART NUMBER
Air filter (914 UL, 912 iS).	Cylindrical air filter.	K&N RU0800
Air filter (912 ULS).	Flat / square air filter.	K&N 33-2673
Fuel filter (914 UL, 912 iS).	90° Mesh filter.	EN-FIL-005-X-X-0 (Airplane Factory part no.)
Fuel filter (912 iS).	GUD E14 fuel (petrol) filter.	
Oil filter.	Rotax.	Rotax part no.825010(012)
Nose wheel tyre.	5.00-5 (6-ply).	UN-TYR-001-X-A-0 (Airplane Factory part no.)
Main wheel tyre.	15.00 x 6.00-6 (6-ply).	UN-TYR-003-X-A-0 (Airplane Factory part no.)
Nose wheel inner tube.	4.10/3.50-5.	UN-TUB-001-X-X-0 (Airplane Factory part no.)
Main wheel inner tube.	15 x 6.00-6.	UN-TUB-002-X-X-0 (Airplane Factory part no.)
Spark plug(s).	Refer to the latest revision of the Rotax 912 ULS / 912 iS / 914 UL operator manual and / or maintenance manuals, as applicable.	

**1.21. AIRCRAFT PLACARDS AND EQUIPMENT LABELLING**

**1.21.1 MARKINGS AND PLACARDS**

**MAGNETIC COMPASS COMPENSATION TABLE**

To compensate for the deviation errors of the magnetic compass, the following correction table is located just below the compass:

For	N	30	60	E	120	150
Steer						
For	S	210	240	W	300	330
Steer						
DATE:						

**BRAKE**

The brake lever is located on the central tunnel between the two front seats and is indicated by a BRAKE label.

**PARKING BRAKE / VALVE**

The park brake shutoff valve is located to the rear of the central tunnel between the two front seats and is indicated by a PARK BRAKE label. ON and OFF labels indicate the setting / activation.

**ENGINE THROTTLE**

A throttle control knob is located on the central cabin channel and is labelled FULL THROTTLE (forward position) and IDLE (rear position).

### **CABIN HEAT**

The cabin heat control knob is located on the instrument panel central area and is labelled CABIN HEAT.

### **TRIM SWITCH**

The elevator trim motor control is located on the top of the control stick and is labelled UP and DN.

### **CIRCUIT BREAKERS**

Fuses are located on the lower right side of the instrument panel and each breaker is individually labelled.

### **FLAPS**

The flap control is located on the instrument panel and is labelled FLAPS. Flap positions are labelled as UP, 1, 2 and 3 (from top of controller to bottom).

### **AND STARTER SWITCH**

A key switch located on the upper left side of the instrument panel acts as a master and starter switch. It is labelled ON and START.

### **CHOKE**

A choke activation knob is found centrally on the instrument panel and is labelled CHOKE (914 UL, 912 ULS).

### **ALTERNATOR LIGHT**

An alternator warning light is located on the upper left side of the instrument panel and is labelled CHARGE.

### **TURBOCHARGER WARNING LIGHTS (914 UL)**

Two turbocharger / TCU warning lights are located on the upper left side of the instrument panel and are labelled BOOST and CAUTION.

### **EFIS WARNING LIGHT**

An EFIS warning light is located on the upper left side of the instrument panel and is labelled EFIS WARNING.

### **FUEL SELECTOR VALVE:**

A fuel selector valve is located on the central tunnel / console and is labelled OFF, LEFT and RIGHT (for Sling 2) or OFF, ON and OFF (for Sling LSA), indicating selection. The selector lever is labelled FUEL.

### **ELECTRIC FUEL PUMPS**

914 UL, 912 IS:

The electric fuel pumps are activated by switches on the upper left of the instrument panel and are labelled MAIN PUMP and AUX PUMP.

912 ULS:

The electric fuel pump is activated by a switch on the instrument panel and is labelled FUEL PUMP.



## **BAGGAGE COMPARTMENT**

A placard indicating the maximum weight is present on the baggage compartment separator channel.

SLING 2:

**MAX TOTAL BAGGAGE WEIGHT – 35 KG / 77 LB**  
**MAX FRONT SECTION 35 KG / 77LB**  
**MAX REAR SECTION 25 KG / 55 LB**

SLING LSA:

**MAX TOTAL BAGGAGE WEIGHT – 15 KG / 33 LB**  
**MAX FRONT SECTION 15 KG / 33LB**  
**MAX REAR SECTION 15 KG / 33 LB**

FUEL TANKS:

Next to each fuel tank filler cap is located a placard indicating the type of fuel and the total tank capacity.

**AVGAS**  
**OR**  
**MOGAS**  
**75 LITRES**

**TYRE PRESSURE:**

On each main wheel fairing is a placard indicating tyre pressure (2.2 bar).

On the nose wheel fairing is a placard indicating tyre pressure (1.8 bar).

**IDENTIFICATION PLATE:**

The following stainless steel placard is located on the central console inside the aircraft cabin (where ### denotes data unique to each individual aircraft and X denotes 2 or LSA, as the case may be):

914 UL ENGINE (SLING 2):

<p><b>ZU-###</b> <b>CONSTRUCTOR – THE AIRPLANE FACTORY</b> <b>MODEL – SLING 2</b> <b>AIRCRAFT SERIAL NUMBER – ###</b> <b>ENGINE ROTAX 914 UL 115 HP</b> <b>MANUFACTURED: ###</b></p>
--

912 ULS ENGINE (SLING 2, SLING LSA):

<p><b>ZU-###</b> <b>CONSTRUCTOR – THE AIRPLANE FACTORY</b> <b>MODEL – SLING X</b> <b>AIRCRAFT SERIAL NUMBER – ###</b> <b>ENGINE ROTAX 912 ULS 100 HP</b> <b>MANUFACTURED: ###</b></p>
---

912 iS ENGINE (SLING 2, SLING LSA):

<p><b>ZU-###</b> <b>CONSTRUCTOR – THE AIRPLANE FACTORY</b> <b>MODEL – SLING X</b> <b>AIRCRAFT SERIAL NUMBER – ###</b> <b>ENGINE ROTAX 912 iS 100 HP</b> <b>MANUFACTURED: ###</b></p>
--

**LIMITATION PLACARDS:**

Located on the instrument panel are the following placards:

SLING 2:

**OPERATE UNDER VMC ONLY**  
**MAXIMUM PERMISSIBLE AIRSPEED 135 KIAS**  
**MAXIMUM PERMISSIBLE RPM 5 800 RPM FOR 5 MINUTES**  
**MAXIMUM CONTINUOUS RPM 5 500**  
**MAXIMUM PERMISSIBLE MASS 700 KG / 1 543 LB**

SLING LSA:

**OPERATE UNDER VMC ONLY**  
**MAXIMUM PERMISSIBLE AIRSPEED 135 KIAS**  
**MAXIMUM PERMISSIBLE RPM 5 800 RPM FOR 5 MINUTES**  
**MAXIMUM CONTINUOUS RPM 5 500**  
**MAXIMUM PERMISSIBLE MASS 600 KG / 1 323 LB**

SLING 2 and SLING LSA:

**WARNING**  
**NON TYPE CERTIFIED AIRCRAFT**  
**THIS AIRCRAFT IS NOT REQUIRED TO COMPLY WITH ALL THE**  
**REGULATIONS FOR TYPE CERTIFIED AIRCRAFT**  
**YOU FLY IN THIS AIRCRAFT AT YOUR OWN RISK**

**NO SMOKING**

**WARNING**  
**AEROBATICS AND INTENTIONAL SPINS ARE**  
**PROHIBITED**

Located on each flap is a placard that identifies the no-step area:

**NO STEP**

## 1.20. GENERAL SAFETY INFORMATION / CONSIDERATIONS

Ensure that the ballistic parachute (if fitted) lever lock mechanism is in place during all repair and servicing work.



Never work on an aircraft if the appropriate safety equipment (fire extinguisher, first aid kit, etc.) is not present and serviceable.

Always use appropriate safety attire when working on an aircraft.

Wear protective eye wear when working on an aircraft, especially when inflating or deflating tyres, working with power tools, with fluids or when working with pressurized air equipment.

Always use the correct tools for a specific task.

Always ensure that the magneto / ignition switches are OFF before working on a propeller or the engine.

Ensure that the Master switch is OFF / electrical equipment switches are OFF before removing or fitting electrical wiring, electrical equipment or electrical / electronic instruments. Consider disconnecting the battery earth wire before working on electrical equipment.

Never disassemble a wheel or release the wheel assembly bolts before the tyre has not been completely deflated, as explosive separation of the wheel assembly may occur if done so before the pressure is relieved.

Never attempt to remove the valve core before the tyre is completely deflated. The core may eject at high velocity if unscrewed before the pressure is relieved.

Never use oxygen to inflate a wheel / tyre.

It is advisable to inflate the tyre on a newly assembled wheel assembly in a cage built for that purpose.

Spilled hydraulic fluid, brake fluid and fuel represent a safety hazard. Blank off disconnected fluid lines to prevent drip and / or spillage. Clean up any spilled fluid before continuing with work.

Ensure adequate lighting when working on an aircraft.

Always work in well ventilated areas, especially when working with chemicals / fluids.

Ensure that the aircraft is stable and cannot inadvertently / unexpectedly move (e.g. roll forward or backward or fall of jacks or supports) before starting work on it.

Never smoke when working on or in the vicinity of an aircraft.

**1.21. INSTRUCTIONS FOR CONCERNS REGARDING SAFETY OF FLIGHT**

If any person should have any concerns regarding the safety of an Airplane Factory Sling 2 for flight, these should be emailed to sales@airplanefactory.co.za. The following information should be included in the email:

- Aircraft make, model and serial number.
- Engine make, model and serial number.
- Date of last inspection.
- Airframe total time.
- Engine total time.
- Description of the un-airworthy items found.
- Aircraft owner.

Alternatively, write to:

The Airplane Factory, PO Box 308, Eikenhof, 1872, South Africa.

## SECTION 2

# INSPECTION

This section provides information regarding general inspection considerations, inspection schedules and inspection procedures.

### 2. INTRODUCTION

This section should be read in conjunction with section 3.

#### 2.1. GENERAL CONSIDERATIONS REGARDING INSPECTION

Inspections performed on an aircraft should be performed in accordance with acceptable standards, such as described in, for example, the FAA Advisory Circular AC43.13-1B: Acceptable Methods, Techniques and Practices - Aircraft Inspection and Repair.

##### **STRUCTURE(S) IN GENERAL:**

Inspect for the condition of panel covers, ribs, frames, stringers etc, absence of cracks, deformation, rivet slackening, corrosion and any other apparent sign(s) of damage.

##### **CABLES AND PUSHRODS:**

Inspect cables for broken strands, kinks, excessive wear, corrosion, security of attachment, binding and correct tension.

Inspect pushrods for alignment, freedom of movement and security of attachment of rod-end bearings.

##### **SAFETY EQUIPMENT:**

Inspect seat belts / safety harnesses for security of attachment, correct operation of buckles and couplings and integrity of the webbing and webbing-to-coupling connections.

Inspect fire extinguisher(s) for correct type, currency (inspection / service period), correct pressure indication, security of attachment and correct disengagement from mounting bracket.

Inspect first-aid kit for currency and compliance with national regulations.

**MOVING PARTS:**

Lubrication, security of attachment, safety'ing of bolts, binding, excessive play, excessive wear, proper adjustment, correct travel, condition of attachments and hinges, absence of corrosion, deformation, condition of bearings, sealing, rivet slackening, cleanliness, tension (cables), cracks.

**COMPOSITE PARTS:**

Inspect for racks, dents and delamination.

**FLUID LINES, HOSES, TUBES AND CONNECTIONS:**

Inspect for leaks, cracks, kinks, nicks, cuts, twisting, any form of collapse, chafing, proper radius, any form of deterioration, security of attachment, corrosion of fitments / couplings.

In addition to the above metal fluid lines / tubing should be free of dents.

**FILTERS:**

Inspect for cleanliness, damage and security of attachment.

**FLUIDS:**

Inspect for contamination.

**BOLTS, NUTS, SAFETY WIRE, SPLIT PINS AND ATTACHMENTS:**

Inspect for proper tightening and safety'ing, absence of cracks or nicks, corrosion, damage to thread, wear and excessive play.

Ensure that safety wire is installed in such a manner as to prevent the loosening of the part to which it is applied.

Verify the use of correct specification of bolts, nuts and connecting hardware.

Observe creep marks for any indication of creep.



### **ELECTRICAL WIRING, BONDING, CONNECTION, CIRCUIT BREAKERS AND SWITCHES:**

Inspect for security of attachment, any sign of arcing, fraying, burning, defective (brittle, nicked, cracked, cut or penetrated in any manner) insulation , loose or broken terminals, heat deterioration, discolouration and corroded terminals.

Inspect bonding connections for proper attachment and corrosion.

Inspect switches for any abnormal side-to-side movement. Inspect switches for security of attachment.

Give consideration to the possibility that an incorrect switch substitution could have been made during maintenance (i.e. inspect for the correct switch rating).

Give consideration to the possibility that an incorrect circuit breaker substitution could have been made during maintenance (i.e. inspect for the correct circuit breaker rating).

Inspect for the correct labelling of switches and circuit breakers.

### **BATTERY:**

Inspect for security of attachment, correct rating, sufficient charge, physical integrity, leakage and cracks. Inspect the battery terminal connections for security of attachment, cracks and corrosion.

### **TYRES AND WHEELS:**

Verify for correct inflation of tyres.

Inspect for worn spots, bulges in the tyre sidewall, cracks, cuts or embedded objects.

Inspect for tread wear.

Inspect the wheel hub for cracks, nicks, warping or for any kind of damage.

### **INSTRUMENTS:**

Inspect instruments for security of attachment, sensible indication, absence of cracks in viewing glass of the instrument and absence of moisture behind the viewing the glass of the instrument. Inspect for cracks in instrument enclosures / bodies / frames.

Inspect for proper connection of instruments to electrical wiring and / or pneumatic tubes and couplings.

Give consideration to the possibility that an analogue instrument could have been replaced by an instrument with incorrect markings (e.g. the colours speed range markings on an airspeed indicator), incorrect range or alternative units of measurement.

Verify the correct settings on electronic instruments.

#### **DOCUMENTATION:**

Verify that the documents required by the current national regulations are present, correct and up to date.

#### **PLACARDS, LABELLING AND INSTRUCTIONS:**

Inspect for the presence and correctness of any placards or notices which are required by the current national regulations.

Inspect for the proper labelling of equipment, switches and control levers.

### **2.2. INSPECTION PANELS**

Inspection points/ locations that are not in plain view may be accessed through specific inspection holes and inspection hatches and / or by the removal of panels or fairings, as detailed below:

- Inspection hatches on the wing underside provide access to the aileron bellcrank and flap torque tube and pushrod.
- Covers on the underside of the wing and at the wing to-fuselage connection points provide access to engine fuel supply and return line connections to the tank, tank level sender, tank level sender-wiring connectors, flap and aileron control pass-throughs and rear spar connections (the front spar connection is accessed inside the cabin).
- Small round tail cone side holes provides access to the elevator control horn and pushrod end.
- The vertical and horizontal tail nacelle / fairings provide access to vertical and horizontal tail mounting and connections.
- The elevator left lower (under elevator) inspection hatch allows access to trim tab motor and trim tab pushrod.
- Inspection panels on ventral rear fuselage allows for inspection of the elevator cable guides.
- Baggage compartment floor inspection panels provide access to the cables for rudder control.
- Cabin longitudinal divider side inspection hatches provide access to fuel lines, rudder cables, throttle cables and the fuel filters.
- The instrument panel cover provides access to the aircraft instrumentation and the related wiring and pneumatic connections.
- The engine cowling provides access to the engine and related systems, access to the components of the electrical system located forward of the firewall and access to the nose gear strut and steering assembly mechanism.
- The propeller spinner provides access to the propeller hub.
- A clear lens in each wing provides access to the landing and taxi lights.

## **2.3. INSPECTION SCHEDULE**

The Airplane Factory considers the inspection schedule outlined below as compulsory for the safe operation of the airframe and systems over an extended period of time. The described servicing requirements pertain to operation in non-extreme climatic / environmental conditions.

### **2.3.1 ENGINE**

Comply with the inspection schedule as indicated in the latest revision of the Rotax 912 ULS / Rotax 912 iS / 914 UL engine maintenance and / or operator manuals, as applicable.

### **2.3.2 PROPELLER**

Comply with inspection schedule as indicated in the latest revision of the propeller operator's manual / installation and operation manual.

### **2.3.3 AIRFRAME AND SYSTEMS**

The airframe and systems inspection schedule is as follows:

- Inspection for airworthiness before the first flight of the day, as specified in the Pilot Operating Handbook.
- Condition inspection at every 100 hours. Refer to paragraph 2.4.
- Special inspections, added to normal periodic inspections, e.g. annual inspections which may be required by national legislation.
- Singular inspection(s), when the aircraft has been exposed to conditions that may have damaged one or more of its components.
- If the aircraft is used infrequently a 100 hour inspection must be performed annually. Refer to paragraph 2.4.

## **2.4. CONDITION INSPECTION (100 HOUR / ANNUALLY)**

### **2.4.1 INSPECTION PANELS AND INITIAL INSPECTION AND CLEANING**

Each person performing an annual or 100 hour inspection shall, before that inspection:

1. Remove or open all necessary inspection panels, access doors, fairings and cowlings.
2. Clean the aircraft and aircraft engine, after an initial visual inspection for oil, exhaust or other leaks.

### **2.4.2 FUSELAGE GROUP**

1. Inspect skin for deterioration, distortion, other evidence of failure, and defective or insecure attachment of fittings.
2. Inspect systems and components for improper installation, apparent defects and unsatisfactory operation.

### **2.4.3 CABIN AND COCKPIT GROUP**

1. Inspect for cleanliness and for loose equipment that might foul the controls.
2. Inspect the seats and safety belts / harnesses for condition and / or any defects.
3. Inspect canopy and windows for deterioration and breakage.
4. Inspect instruments for poor condition, mounting, marking, and (where applicable) improper operation.
5. Inspect flight and engine controls for improper issues.
6. Inspect all systems for improper installation, poor general condition, apparent and obvious defects and insecurity of attachment.
7. Inspect the fire extinguisher for security of attachment, correct pressure and currency of service period.

#### 2.4.4 ENGINE AND COWLING GROUP

1. Inspect the engine section for visual evidence of excessive oil, fuel or hydraulic leaks, and sources of such leaks.
2. Inspect studs and nuts for improper torque and obvious defects.
3. Inspect entire engine mount for cracks, looseness of mounting, and looseness of the engine to mount connection.
4. Inspect flexible vibration dampeners for poor condition and deterioration.
5. Inspect engine control linkages for defects, improper travel and improper safety'ing.
6. Inspect lines, hoses and clamps for leaks, improper condition and looseness.
7. Inspect exhaust stacks for cracks, defects and improper attachment.
8. Inspect accessories for apparent defects in security of mounting.
9. Inspect all systems for improper installation, poor general condition, defects and insecure attachment.
10. Inspect electrical and instrumentation wiring for proper attachment and any signs of defects.
11. Inspect cowling for cracks and defects.
12. Comply with any inspection requirements as stipulated in the latest revision of the Rotax 912 ULS / 912 iS / 914 UL operator's manual and / or maintenance manuals, as applicable.

#### 2.4.5 LANDING GEAR GROUP

1. Inspect all parts for poor condition and insecurity of attachment.
2. Inspect shock absorbing devices (spring on nose gear) for damage.
3. Inspect members for undue or excessive wear, fatigue and distortion.
4. Inspect hydraulic lines for leakage.
5. Inspect wheels for cracks, defects and condition of bearings.
6. Inspect tyres for wear, cuts and slippage.
7. Inspect brakes for improper adjustment.

#### **2.4.6 WING AND CENTRE SECTION ASSEMBLY**

Inspect for:

1. Poor general condition.
2. Skin deterioration.
3. Distortion.
4. Evidence of failure.
5. Insecurity of attachment.

#### **2.4.7 EMPENNAGE ASSEMBLY**

Inspect all components and systems for:

1. General condition.
2. Skin deterioration.
3. Distortion.
4. Evidence of failure.
5. Insecurity of attachment.
6. Improper component installation.
7. Improper component operation.

#### **2.4.8 PROPELLER GROUP**

Inspect propeller assembly for:

1. Cracks.
2. Nicks.
3. Improper torque and lack of safety'ing on propeller attachment bolts.
4. Comply with any inspection requirements as stipulated in the latest revision of the propeller manufacturer operator's manual.

#### **2.4.9 RADIO GROUP / AVIONICS / ELECTRONIC EQUIPMENT**

1. Inspect radio and electronic equipment for improper installation, insecure mounting and correct operation and functionality.
2. Inspect wiring and conduits for improper routing, insecure mounting and obvious defects.
3. Inspect bonding and shielding for improper installation and poor condition.
4. Inspect antenna/e for poor condition and insecure mounting.

#### **2.4.10 OPTIONAL EQUIPMENT**

Check all optional equipment for proper operation. Refer to optional equipment manufactures manuals / documentation.

**2.5. 25 HOUR, 100 HOUR AND ANNUAL SERVICE INSPECTION CHECKLIST**

This checklist must be read / performed in conjunction with the applicable engine and propeller checklists as found in the latest revision of the Rotax 914 UL / 912 ULS / 912 iS engine operator's manual and / or maintenance manuals, as applicable, and the latest revision of the propeller operation / maintenance manual.

<b>ENGINE COMPARTMENT</b>	<b>Propeller</b>	Verify torque for propeller and propeller extension mounting bolts.	
		Verify propeller tracking.	
		Verify security of spinner screws.	
		Verify spinner tracking.	
	<b>Engine mount</b>	Verify torque on bolts securing engine mount to firewall.	
		Verify torque of bolts securing engine to engine mount.	
		Inspect condition and security of rubber engine mounts.	
		Inspect engine mount for any signs of distortion or cracks.	
	<b>Fuel pumps and hoses</b>	Verify fuel pump assembly securely attached to firewall.	914 UL 912 iS
		Electrical wire connections to pumps (in fuel pump assembly) secure and correct.	914 UL 912 iS
		Electrical fuel pump securely attached to firewall.	912 ULS
		Verify security and integrity of fuel hoses from carburetors to pumps (carburetors to mechanical engine driven pump for 912 ULS).	914 UL 912 ULS
		Verify security and integrity of fuel hoses from the mechanical fuel pump to the filter, and from the filter to the electrical fuel pump.	912 ULS
		Verify security and integrity of fuel hoses from engine to filter.	912 iS
		Verify security and integrity of fuel hoses from the filter to the pumps (pump assembly).	912 iS
		Verify security of fuel hoses from pumps (pump assembly) to bulkhead (from electrical fuel pump to bulkhead for 912 ULS).	
Verify that all fuel hoses are clamped and tied down.			
Verify security of breather pipes from carburetors to air box.		914 UL 912 ULS	



ENGINE COMPARTMENT	Spark plugs and coil leads	Spark plugs secure and correct torque.	
		Verify leads secure on spark plugs.	
	Oil system and radiator	Verify correct oil level.	
		Verify that oil drain plug (bottom of oil reservoir) is secure and correctly wire-locked.	
		Verify security of attachment of oil tank and oil tank hose fittings.	
		Verify security and correct routing of oil hoses.	
		Verify oil cooler security of attachment.	
		Verify security of oil cooler fittings and hose clamps.	
		Verify security of oil breather pipe.	
		Verify security of oil filter.	
	Coolant system and radiator	Verify coolant level and type.	
		Verify coolant hose routing and heat shielding.	
		Verify security of all coolant hose clamps.	
		Verify security of overflow bottle.	
	Brakes	Verify that overflow bottle breather hole is clear.	
		Verify fluid level and breather washer correct.	
	Throttle cable and mechanism	Verify security of cable lock-nuts.	
		Cable end(s) secure and free in carburetor / butterfly valve link(s) / arm(s).	
		Security and integrity of lever(s).	
		Security and integrity of lever spring(s).	
		Verify cable adjustment (full throttle).	
		Verify cable adjustment (idle).	
	Choke system	Verify security of cable lock-nuts (both ends).	914 UL/ 912 ULS
		Security and integrity of lever spring(s).	
		Cable ends secure and free in carburetor links.	
		Verify that choke opens and close correctly.	
	Engine air intake system	Verify the security of the clamps, and the security and integrity of the air hoses from the intake air distributor air box to the carburetors.	912 ULS 914 UL
		Visually inspect the rubber flanges (connecting the carburetors to the engine intake manifolds) for cracks or hardening.	912 ULS 914 UL

ENGINE COMPARTMENT		Rubber flanges (connecting the carburettors to the engine intake manifolds) secure to engine and securely clamped to carburetors.	912 ULS 914 UL
		Verify the security of the clamps, and the security and integrity of the air hoses from the air box to the engine.	912 iS
		Verify the security of the clamps, and the security and integrity of the air hose from the turbocharger compressor to the intake air distributor air box.	914 UL
		Air filter enclosure integrity and securely clamped to the butterfly valve assembly intake.	912 iS
		Air filter enclosure integrity and securely clamped to turbocharger. Air filter enclosure correctly safety wired.	914 UL
		Verify the security of the clamps, the security, integrity and correct / unobstructed routing of the air hose from the NACA duct (in cowling side) to the air filter enclosure (914 UL/ 912 iS) or air box / filter enclosure (912 ULS).	
		Security of airbox attachment (p-clamps) to engine suspension mount.	912 ULS
	Nose gear assembly	Integrity of fork and strut (no cracks, distortion).	
		Tyre in serviceable condition.	
		Correct tyre pressure.	
		Free nose wheel rotation.	
		Verify lubrication and ease of rotation of nose gear strut.	
		Verify security of all bolts / nuts in nose gear assembly / nose gear attachment points.	
		Verify that air valve grommet is in place on spat.	
		Verify security of spat retaining screws.	
		Verify the security of the steering linkage rod ends.	
		Verify spats clear of wheels.	
		Verify the security of the steering linkage pushrod lock-nuts.	
	Verify presence and integrity of steering link pushrod boots.		
	Electrical and transducers (sensors)	Verify security of battery tie down and battery bracket.	
Verify security of battery terminals.			
Verify battery positive terminal rubber boot in place.			

ENGINE COMPARTMENT		Verify security of battery earth on firewall.		
		Verify security of starter solenoid mounting lock-nuts and wires / wire terminals. Verify presence and integrity of wire boots on terminals.		
		Verify security of all transducers / sensors (oil pressure, temperature, cylinder head temperature, sensors attached to air box (914 UL, 912 iS), propeller slip ring pick-up (if fitted) etc. and security and integrity /correctness of all transducer / sensor wiring.		
		Verify security of wiring and connectors to RDAC.	912 UL 914 ULS	
		Verify security of wiring and connectors to TCU and waste gate servo.	914 UL	
		Verify security of wiring and connectors to fuse box.	912 iS	
		GPS antenna secure.		
		Verify all wiring tied down and secure.		
	General		Verify security of attachment (to bulkhead) of waste gate servo.	914 UL
			Verify security of attachment (to firewall) of TCU (turbocharger control unit).	914 UL
			Verify security of attachment (to firewall) of RDAC unit.	914 UL 912 ULS
			Verify security of attachment of the manifold pressure hose to the RDAC unit and the intake manifolds. Verify the integrity of the hose.	914 UL 912 ULS
	Cabin heat		Verify integrity and security of attachment of air hose between heat exchanger / muffler and air splitter box on firewall.	
			Verify operation.	
	Exhaust / muffler		Verify integrity and security of attachment.	
			Security and integrity of exhaust joint springs and safety wire.	912 iS.
	Firewall rubber pass through grommets		Security and integrity.	

INTERIOR	Placards	All required placards present, legible and correct.	
	Seats	Seat security, integrity and correct operation of adjustment lever / mechanism.	
	Ballistic Recovery System (parachute) cable attachment points (if fitted)	Security and integrity of front cable attachment points.	
		Security and integrity of rear cable attachment points (on main undercarriage bolts)	
	Electrical and avionics	Verify correct operation of (alternator) charge light.	
		Verify security of landing, taxi and navigation / strobe light connectors / connections.	
		iBOX electrical wires and connectors secure. iBOX securely attached.	
		EFIS back-up battery wires / terminals secure. Battery securely attached.	
		ECU wires and connectors secure. ECU securely attached.	
		Flap controller wires and connectors secure. Flap controller securely attached.	
		RDAC wires / connectors secure. RDAC securely attached.	912 iS
		AHRS wires and connectors secure. AHRS securely and correctly attached.	
		Electronic compass wires and connectors secure. Electronic compass securely and correctly attached.	
		Verify integrity of all electrical wires and all wires tied down and secure.	
		Verify security and operation of adjustable interior (red) light.	
		Security and correctness of regulator wiring. Regulator securely attached to bulkhead.	
	Rudder	Verify security of rudder pedal mounts.	
Security of rudder pedal adjustment bolts.			
Verify security and integrity of rudder cables.			

INTERIOR		Verify the security of the steering linkage rod ends.	
		Verify deflection (left and right).	
		Verify steering linkage rod end free play at full deflection, in both directions.	
		Verify rudder stops secure and not catching.	
		Verify integrity and security of attachment of rudder centering springs.	
	Fuel system	Verify security of fuel filters.	
		Verify security of fuel hoses from valve to bulkhead.	
		Verify security of fuel hoses from fuel selector valve to filters.	
		Verify security of fuel hoses from filters to tanks.	
		Verify correct and unobstructed fuel hose routing.	
		Verify correct fuel selector valve operation.	
		Verify security of fuel selector valve mounting.	
	Brakes	Integrity of brake lines and securely tied down.	
		Verify correctness and security of brake handle assembly.	
		Verify security of brake lever pivot and split pin.	
		Rod end secure.	
		Lock-nuts secure.	
		Verify correct operation of brakes.	
		Free play.	
		Verify correct operation of park brake.	
		Verify assembly and correct operation of toe brakes (if fitted) at full deflection.	
		Verify correct connection of left and right toe brakes (if fitted).	
	Throttle	Cable adjuster correct.	
		Cable alignment correct.	
		Cable end free in output lever.	
		Output lever secure.	
		Input lever friction correct.	

INTERIOR		Throttle stops correct and secure.	
	Control sticks	Control stick pivot / pivot bolts secure and pivot arm / bracket securely riveted to longitudinal torque tube.	
		Control stick tube securely riveted to bracket.	
		Switch labelling correct.	
	Aileron control system and linkages	Verify integrity and security of longitudinal torque tube mounting brackets and integrity and security of bushes and locking rings.	
		Control arms / horns securely riveted to longitudinal torque tube.	
		Pushrods correctly adjusted.	
		Rod ends secure.	
		Pushrod lock-nuts secure.	
		Rod ends free at full deflections.	
		Stops secure.	
	Elevator control system and linkages	Verify integrity and security of lateral torque tube mounting brackets and integrity and security of bushes and locking rings.	
		Control arms / horns securely riveted to lateral torque tube.	
		Pushrods correctly adjusted.	
		Rod ends secure.	
		Pushrod lock-nuts secure.	
		Rod ends free at full deflections.	
	Aileron autopilot servo	Security of servo attachment to fuselage.	
		Verify rod ends secure (both ends).	
		Security and integrity of servo wires and connectors.	
	Elevator autopilot servo and linkage	Security of servo attachment to fuselage.	
		Verify rod ends secure (both ends).	
		Security and integrity of servo wires and connectors.	
	Flap actuator system	Flap actuator motor cable connector integrity and security.	
Flap actuator motor secure and split pins present in pivot bolts..			
Verify integrity and security of lateral torque tube mounting brackets and integrity and security of bushes.			

INTERIOR		Control arm / horn securely riveted to lateral torque tube.		
		Flap torsion bar and connector tube bolts secure.		
	Safety harness		Verify integrity of belt canvass and stitching.	
			Buckle free play.	
			Verify operation.	
			Belts not twisted.	
			Seat belt anchors secure.	
	Headphones		Hooks secure.	
			Jacks secure.	
			Wiring to jacks secure and correct.	
	Instrument panel		Secure.	
			Instruments secure and correctly installed.	
			Switches secure.	
			Switch and control labelling correct.	
			Registration on panel.	
			Slip indicator (balance ball) air bubble not visible.	
			Magneto switch guard in place (if separate magneto switches).	
			Instrument markings correct.	
			Altimeter indicates correctly with QNH / QFE set.	
			All instruments operational.	
	Upholstery		Serviceable and clean.	
			Map pockets serviceable.	
	Canopy		Verify correct operation.	
			Verify catch security, correct operation and correct operation of key lock mechanism.	
			Integrity of transparent surface (no cracks, deformations, etc).	
			Integrity of canopy frame.	
			Visual inspection on seal integrity.	

EXTERIOR	Wings	Inspect root / mounting bolts and verify correct torque.	
		Security and integrity of fuel pipes and fittings.	
		Verify correct and symmetric flap deflection: First stage: 10°, Second stage: 20°, Third stage: 30°, Up: 0°.	
		Flap hinge points / bolts secure.	
		Flap system rod ends secure.	
		Flap system pushrod lock-nuts secure.	
		Flap system rod ends free at full deflections.	
		Bellcrank secure and rigged correctly.	
		Verify correct aileron deflections: up, down and neutral.	
		Aileron hinge bolts secure and correct spacing.	
		Aileron system rod ends secure.	
		Aileron system pushrod lock-nuts secure.	
		Aileron system rod ends free at full deflections.	
		Verify pitot tube security.	
		Verify correct operation of pitot tube.	
		Security of navigation lights and lens integrity.	
		Security and integrity of taxi / landing light clear lenses / covers.	
		Verify operation of navigation / strobe lights.	
	Verify operation of taxi and landing lights.		
	Fairing secure.		
	Boarding steps	Security of attachment to fuselage and integrity.	
	Main undercarriage	Tyres in serviceable condition.	
		Correct tyre pressure.	
		Verify ease of rotation of main wheels.	
		Calipers secure.	
		Stub axles secure and serviceable.	
		Hubs secure and serviceable.	
		Discs secure and serviceable.	
		Verify security of main leg attachment bolts.	
Verify security of spat retaining screws.			
Verify spats clear of tyres.			
Verify air valve grommet in place.			



EXTERIOR		Security of attachment of brake lines to main undercarriage legs.	
	Fuel	Verify security of fitment of fuel filler caps.	
		Fuel drains secure.	
		Verify operation of fuel drains.	
		Verify presence of fuel decals at filler opening.	
	Elevator	Hinges and hinge bolts / lock-nuts secure.	
		Rod end secure and pushrod locknut secure.	
		Verify rod end free play at full deflections.	
		Verify elevator deflections: up, down.	
	Elevator trim tab and motor	Security of trim motor attachment.	
		Security and integrity of trim motor electrical connector and wiring.	
		Trim tab hinge secure.	
		Trim tab pivot secure (split pin present).	
		Pushrod locked.	
		Verify operation.	
	Rudder	Trim tab adjusted correctly (deflections correct).	
		Correct deflections: left, right.	
		Hinges and hinge bolts / lock nuts secure..	
		Cables secure and correctly crimped.	
		Strobe light security.	
	Empennage	Verify strobe light operation.	
		Vertical stabilizer mounting bolts / lock-nuts secure.	
		Horizontal stabilizer mounting bolts / lock-nuts secure.	
Security and integrity of rudder strobe light electrical connector and wiring.			
Antenna / antennae	Fairings secure.		
	Verify security of attachment.		

## **SECTION 3**

### **SERVICE**

This section provides information regarding general service considerations and service schedules.

#### **3. SERVICE - INTRODUCTION**

This section should be read in conjunction with Section 2.

#### **3.1 GENERAL CONSIDERATIONS REGARDING SERVICE AND MAINTENANCE**

Work, maintenance and servicing conducted on aircraft should be performed in accordance with acceptable standards, such as described in, for example, the FAA Advisory Circular AC43.13-1B: Acceptable Methods, Techniques and Practices - Aircraft Inspection and Repair.

Removed parts should be replaced with parts with the same part number, from the same manufacturer, to ensure correct specification and safe operation. Refer to the current manufacturer documentation in this regard.

#### **STRUCTURES IN GENERAL:**

Any structural repair to the aircraft should be performed by qualified and trained personnel. Refer to the aircraft manufacturer.

#### **CABLES AND PUSHRODS:**

Service as required.

#### **SAFETY EQUIPMENT:**

Service according to any applicable national regulations, calendar based requirements and manufacturer recommendations and instructions.

### **LUBRICATION:**

Periodic lubrication of moving parts ensures proper operation and extends part lifetimes considerably.

Avoid excessive lubrication as this may cause external surfaces of hinges and bearings to collect dirt and dust.

If a part is lubricated by hand, remove excess grease.

### **MOVING PARTS:**

Lubricate as required with the correct lubricant, as specified for the part.

### **COMPOSITE PARTS:**

Repair cracks, dents and delamination as necessary.

### **FLUID LINES, HOSES, TUBES AND CONNECTIONS:**

Fluid lines should be replaced with lines of the same part number, material, size (inner and outer diameter), pressure rating and length (of the line to be replaced).

Allow enough slack in flexible hoses for stretch when pressure is applied / removed.

Do not twist flexible hoses and metal lines.

Metal end fittings should not be considered as part of the flexible section of a flexible hose.

Keep the bend radius of installed flexible hoses as large as possible to avoid collapse.

When installing seals into end fittings, ensure that the seal is not scratched, cut or damaged.

**BOLTS, NUTS, WASHERS, SAFETY WIRE, SPLIT PINS AND ATTACHMENTS:**

Lock-nuts, lock-washers, split pins and safety wire should not be reused after removal. Fit new.

If in need of replacement, replace bolts, nuts, washers and connecting hardware with items of the same specification.

Ensure bolt and nut threads are clean and dry before fitment, unless otherwise specified by the manufacturer.

Inspect all bolts, nuts and screws for damage and corrosion before reinstallation. Replace if necessary.

Apply safety wire and / or split pins as required.

Do not overstress safety-wire, as it will break under vibration if twisted to tightly. It is preferable to twist safety wire with locking pliers. If safety wire is to be twisted by hand, ensure 6 to 8 twists per inch (25.4 mm).

Ensure that safety wire is installed in such a manner as to prevent the loosening of the part to which it is applied.

Where specified, bolts and nuts should be torqued to the indicated value. Use a calibrated torque wrench with adequate range. Where possible, apply the torque to the nut and not the bolt. This will prevent rotation of the bolt in the hole and will reduce wear on the bolt hole.

Where applicable apply creep marks to bolts and nuts.

**ELECTRICAL WIRING, BONDING, CONNECTION, CONNECTORS, CIRCUIT BREAKERS AND SWITCHES:**

Electrical wiring and cables must be replaced with wire and cables of the same rating and specification.

Replace defective switches with switches of equivalent rating.

Circuit breakers should be replaced with circuit breakers of identical rating.

Circuit breakers (if of the type operable by hand) should be periodically cycled with NO LOAD (i.e. with the electrical system turned of) to enhance contact performance.

Electrical connectors should be replaced with connectors of the same mechanical specification and electrical rating.

### **FILTERS**

Replace as required.

### **FLUIDS:**

Replenish fluids as required with the correct specification fluid.

Do not mix hydraulic / brake fluid and / or coolant fluid of different specifications or from different manufacturers complying to the same specification. Drain the system, flush and replenish.

### **TYRES AND WHEELS:**

Tyres should be inflated to the recommended pressures. Incorrect inflation can cause excessive wear and tyre imbalance.

Tyres should be marked and indexed (i.e. apply creep marks) with the wheel rim to enable the detection of tyre slippage.

### **INSTRUMENTS:**

Service instruments according to any applicable national regulations (if any) and the manufacturer recommendations and instructions. Refer to the latest revision of the instrument manufacturer documentation.

### **DOCUMENTATION:**

Verify that the documents required by the current national regulations are present, correct and up to date.

## PLACARDS, LABELLING AND INSTRUCTIONS

Inspect for the presence and correctness of any placards or notices which are required by the current national regulations.

Inspect for the proper labelling of equipment, switches and control levers.

## ENGINE

Refer to and comply with the service schedule, requirements and procedures as stipulated in the latest revision of the engine manufacturer operator's manual and / or maintenance manuals, as applicable.

## PROPELLER

Refer to and comply with the service schedule, requirements and procedures as stipulated in the latest revision of the propeller manufacturer operator's manual.

## GENERAL CONSIDERATIONS IN THE ROUTING AND SECURING OF FLEXIBLE FUEL, OIL AND HYDRAULIC PIPES AND ELECTRICAL CABLE / SIGNAL WIRES

In general flexible fuel, oil and hydraulic pipes and electrical cables and signal wires can be tie wrapped to fuselage structures, and to each other, with the aid of a stand-offs / spacers cut from rubber pipe or clear pneumatic pipe, to ensure clearance and prevent chaffing.



Tie wraps should not be tightened to such an extent that distortion of the cross sectional area of flexible pipes occur, or that electrical wire insulation is pinched. Tighten only to the extent necessary to prevent relative movement and chaffing and to ensure secure installation.

### 3.1 LUBRICATION POINTS, LUBRICANTS AND INTERVALS

LUBRICATION POINT		LUBRICANT	INTERVAL
1	Canopy bearings.	Refer to the list of approved lubricants in paragraph 1.4.	As needed.
2	Canopy latches.		As needed.
3	Rudder and pedal control cable terminals.		100 Hours / yearly.
4	Rudder cable guides.		100 Hours / yearly.
5	Elevator pushrod (in centre) guide.		100 Hours / yearly.
6	Elevator torque tube bushes.		100 Hours / yearly.
7	Trim tab hinge.		100 Hours / yearly.
8	Aileron pushrod guide (in the centre of wing).		100 Hours / yearly.
9	Flap torque tube bushes.		100 Hours / yearly.
10	Flap actuator ends.		100 Hours / yearly.
11	Rudder pedal bushes.		100 Hours / yearly.
12	Control stick(s).		100 Hours / yearly.
13	Control stick torque tube bushes.		100 Hours / yearly.
14	Nose gear support blocks.		100 Hours / yearly.
15	Main wheel bearings.		100 Hours / yearly.
16	Propeller	Refer to the <u>latest revision</u> of the propeller operator's manual.	
17	Engine	Refer to the <u>latest revision</u> of the Rotax 912 ULS / 912 iS / 914 UL engine operator's manual and / or maintenance manuals, as applicable.	

### 3.2 SERVICE BULLETINS

In addition to the service information contained herein, any service / inspection / modification bulletins issued by the engine, propeller or aircraft manufacturer should be complied with.

### 3.3 SERVICE SCHEDULE

Refer to and comply with the service schedule and requirements as stipulated in the latest revision of the Rotax 912 ULS / 912 iS / 914 UL operator and / or maintenance manuals, as applicable.

Refer to and comply with the service schedule and requirements as stipulated in the latest revision of the propeller operator's manual / installation and operation manual / manufacturer documentation.

### 3.3.1 SERVICE PERIOD ADJUSTMENT

This paragraph lists items which may have their normal service intervals adjusted due to external influences or circumstances, or changes in operating conditions and / or procedures.

ITEM	REASON FOR ADJUSTING SERVICE PERIOD	NORMAL SERVICE PERIOD	ACTION
Battery	Extreme climates.	100 Hours. Refer to paragraph 3.3.8.	Perform a battery check more frequently than the normal service period. Replace if necessary.
Air filter	Dusty environment.	100 Hours. Refer to paragraph 3.3.8.	Remove and clean the air filter more frequently than the normal service period. Replace if necessary.
Engine Oil	Operating predominantly on leaded AVGAS. The engine is considered to be operated predominantly on leaded AVGAS when run for more than 30% of engine operating time on leaded AVGAS fuel.  Refer to the <u>latest revisions</u> of Rotax Service Information SI-912i-001, SI-912-016 or SI-914-019 and Rotax 912 ULS / 912 iS / 914 UL operator and maintenance manuals for up to date information.		More frequent oil changes required (recommended every 25 hours).  Oil filter change recommended every 50 hours.
As may be stipulated in the <u>latest revision</u> of the Rotax 912 ULS / 912 iS / 914 UL engine operator's manual and / or maintenance manuals, as applicable. As may be stipulated in the latest revision of the propeller operator's manual.			



### 3.3.2 ITEMS WITH CALENDAR BASED SERVICING

This paragraph lists items which must be serviced at specified calendar periods, calculated from the last date of being serviced.

Refer to and comply with the latest revision of the 912 ULS / 912 iS / 914 UL operator's and / or maintenance manuals, as applicable, with regard to calendar based items, if any.

Refer to the propeller operator's manual with regard to calendar based items, if any.

ITEM	PERIOD	ACTION
Engine coolant	As recommended by coolant manufacturer.	Drain and replace.
Fire extinguisher.	As indicated.	Service.
Ballistic parachute rocket (if fitted).	6 Years.	Service.
Ballistic parachute (canopy) (if fitted).	6 years.	Repack.
Muffler / heat exchanger assembly.	5 Years.	Disassemble and inspect. Refer to paragraphs 5.2.10 and 5.2.12 for removal and disassembly instructions.
Any items (if any) as stipulated in the <u>latest revision</u> of the Rotax 912 ULS / 912 iS / 914 UL engine operator's manual and / or maintenance manuals, as applicable, and / or any relevant service instruction.	As indicated.	As described / indicated.
Any items (if any) as stipulated in the <u>latest revision</u> of the propeller operator's manual and / or any relevant service instruction.	As indicated.	As described / indicated.

### 3.3.3 DAILY

The following service requirements should be met on each day that the aircraft is operated:

- Pitot and static ports - Inspect for obstructions.
- Oil - Verify oil level. Refer to paragraph 5.2.6.
- Coolant -Verify coolant level.
- Fuel - Drain some fuel from tanks and inspect for any water and / or sediment.
- Fuel tank vents - Inspect for obstructions.
- Tyres - Inspect for wear, damage and correct pressure.

### 3.3.4 AS NEEDED

The following service requirements should be complied with on an as required basis:

- Lubricate the applicable (as needed) items in paragraph 3.1.
- Replace and maintain tyres as required. Maintain proper tyre pressure.
- If unusual tolerance is found along the transmission route of the elevator control system, replace those parts displaying excessive wear.

### 3.3.5 FIRST 25 HOURS

The following service requirements should be complied with after the first 25 hours of operation:

- Complete the inspection checklist in paragraph 2.5 and rectify any shortcomings.
- Oil change. Refer to the latest revision of the Rotax 912 ULS / 912 iS / 914 UL engine operator's manual and / or maintenance manuals, as applicable.
- Perform all propeller service requirements (if any) in accordance with the provisions of the latest revision of the propeller manufacturer operator's manual / installation and operation manual.
- Perform all engine service requirements (if any) in accordance with the provisions of the latest revision of the Rotax 912 ULS / 912 iS / 914 UL engine operator and / or maintenance manuals, as applicable.

- Verify the propeller and propeller extension mounting bolt torques (refer to paragraph 1.5.2).

### 3.3.6 FIRST 50 HOURS

The following service requirements should be complied with after the first 50 hours of operation:

- Perform all propeller service requirements, if any, in accordance with the provisions of the latest revision of the propeller operator's manual / installation and operation manual / manufacturer documentation.
- Perform all engine service requirements, if any, in accordance with the provisions of the latest revision of the Rotax 912 ULS / 912 iS / 914 UL engine operator's and / or maintenance manuals, as applicable.

### 3.3.7 EVERY 50 HOURS / ANNUALLY

The following service requirements should be complied with after every 50 hours of operation or on an annual basis, whichever comes first:

- Carburettor flanges (914 UL / 912 ULS) - Visually inspect the rubber flanges (connecting the carburettors to the engine intake manifolds) for cracks or hardening. Replace if necessary.
- Engine - perform all engine service requirements, if any, in accordance with the provisions of the latest revision of the Rotax 912 ULS / 912 iS / 914 UL engine operator and / or maintenance manuals, as applicable.
- Propeller – perform all propeller service requirements, if any, in accordance with the provisions of the latest revision of the propeller operator's manual / installation and operation manual / manufacturer documentation.

### 3.3.8 EVERY 100 HOURS / ANNUALLY

The following service requirements should be complied with after every 100 hours of operation or on an annual basis, whichever comes first:

- Complete the inspection checklist in paragraph 2.5 and rectify any shortcomings.
- Battery - Inspect for leakage, loosening of tie in strap, proper charge, integrity of terminal connections and general condition. Perform a battery check using a high quality testing device designed for the purpose.
- Engine oil - Change engine oil and replace oil filter element (refer to the latest revision of the Rotax 912 ULS / 912 iS / 914 UL operator and / or maintenance manuals, as applicable).
- Engine - perform all engine service requirements, if any, in accordance with the provisions of the latest revision of the Rotax 912 ULS / 912 iS / 914 UL operator and / or maintenance manuals, as applicable.
- Brake fluid - Verify the level of the brake fluid in the master cylinder (located on the left upper side of the engine side of the firewall).
- Fuel filter and lines - Visually inspect all fuel lines. Remove and visually inspect the fuel filters. Replace the fuel filters if necessary.
- Lubricate the applicable items as listed in paragraph 3.1.
- Air filter - Remove and clean or replace the air filter, as may be appropriate.
- Propeller - Inspect the attachment bolts for integrity and torque (refer to paragraph 1.5) and safety'ing. Comply with the requirements of the propeller maintenance / operation manual / manufacturer documentation.
- Ailerons, flaps, rudder and elevator - Inspect visually for condition and for absence of cracks, wear etc.
- Tyres - Inspect for condition and maintain proper pressures (refer to paragraph 1.7).
- Inspection for condition - Comply in full with the requirements of the 100 hour / annual inspection and correct all faults or failings.

## SECTION 4

# STRUCTURES, SYSTEMS AND PROCEDURES

This section describes the various structures, substructures, systems and subsystems comprising the aircraft, and describes maintenance procedures applicable to these structures, substructures, systems and subsystems, as the case may be.

### 4. AIRFRAME

The airframe consists of the following main groups:

- Wings.
- Fuselage.
- Empennage.
- Landing gear.

## 4.1 WING

### 4.1.1 MAIN WING SECTION

The wing main spar comprises of an aluminium web with spar caps solid riveted to the top and bottom to form a composite I-beam. The caps are made from sheet material bent into angles. The rear spar comprises an aluminium C-channel with the flanges facing forward.

Each wing is connected to the fuselage by means of nine bolts (eight on the front spar, one on the rear spar).

Two inspection panels are located on the underside of each wing, one providing access to the aileron bellcrank and the other providing access to the flap control arm (attached to the (flap) torque tube). Fore and aft inspection panels are located (on the underside of the wing) at the wing-to-fuselage connection points.

A fuel filler cap is located on upper side of each tank / wing.

Fuel tanks vent by means of a tube exiting the underside of the wing, on the outer tank rib immediately in front of the main spar.

A fuel drain is located on the underside of each wing.

Aileron and flap hinges (on the wing side) comprise of shaped plates mounted on the wing trailing edge.

Wing tips are moulded epoxy resin reinforced with glass fibre.

A pitot tube is located on the underside of the left wing.

**4.1.1.1 WING REMOVAL / INSTALLATION**

TOOLS / EQUIPMENT REQUIRED			
ITEM		QUANTITY	NOTES
1	Calibrated torque wrench, at least 35 Nm range.	1	
2	½ inch Socket, to fit torque wrench in 1.	1	
3	9/16 Socket, to fit torque wrench in 1.	1	
4	½ inch Spanner.	2	
5	3/8 Spanner.	2	
6	7/16 Spanner.	2	
7	2 mm Allen key / hex drive.	1	
8	17 mm Spanner.	1	Fuel line couplings.
9	9/16 Spanner.	2	Fuel line couplings / front spar bolts.

The above list is not necessarily a complete list of all required tools and equipment needed. A calibrated torque wrench (with adequate range) and the correct size (as implied by the above tool list) accessories (sockets etc.) are implied for torquing bolts / nuts, if applicable. Refer to paragraph 1.5 for torque values.

CONSUMABLE MATERIAL REQUIRED			
ITEM		QUANTITY	NOTES
1	Orange paint.	As needed.	
2	Loctite 577.	As needed.	Fuel tank outlet / return line couplings.
3	Tie wraps.	As needed.	Installation only.
4	Loctite 222.	As needed.	Inspection panels and wing-to-fuselage fairing screws.

The above list is not necessarily a complete list of all material needed. Refer to the Sling 2 construction manual.

AUTHORISED PERSONNEL			
Any person performing maintenance of any kind on the aircraft or any component thereof must do so in accordance with national legislation. This is the responsibility of the aircraft owner and any person who is to perform any maintenance on the aircraft.			

**CAUTION**  
**BE PREPARED WITH A HELPER OR SUPPORT STAND TO HANDLE THE WEIGHT AND / OR AWKWARDNESS OF THE OBJECT TO BE REMOVED.**

## PROCEDURE

Retain any bolts, nuts (except lock-nuts) spacers, screws and washers (with the exception of lock-washers) for reassembly.

1. Set the fuel selector (in the cockpit) to OFF.
2. Drain fuel from the wing via the fuel drain valve. If the tank is nearly full a substantial amount of fuel can be siphoned through the filler cap hole.
3. Remove the seat on the side of the wing that is being removed (refer to paragraph 4.3.2.1).
4. Remove the wing-to-fuselage fairings (by unscrewing all the button head screws).
5. Remove the fuel tank outlet / return line inspection panel (1) from under the wing, by unscrewing the button head screws.
6. Disconnect the fuel hoses (2) from the tank outlet and the return line by unfastening the couplings (3). Place / insert temporary caps on / in the fuel lines to prevent spillage and drip.

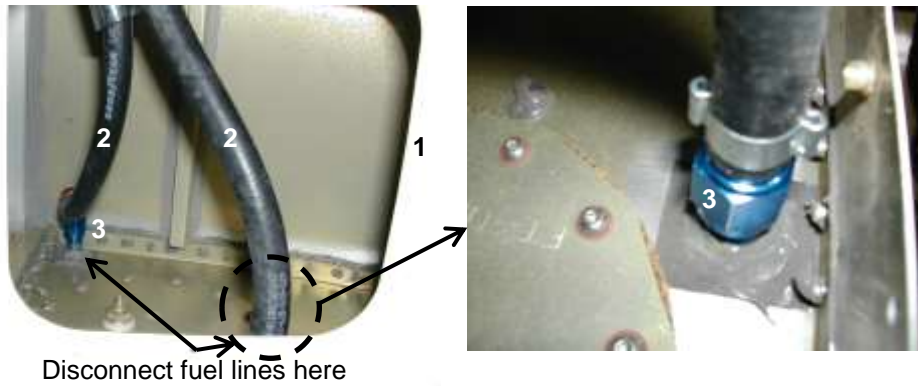

7. For the left wing disconnect the two plastic pitot tubes (4) at the couplings (5).

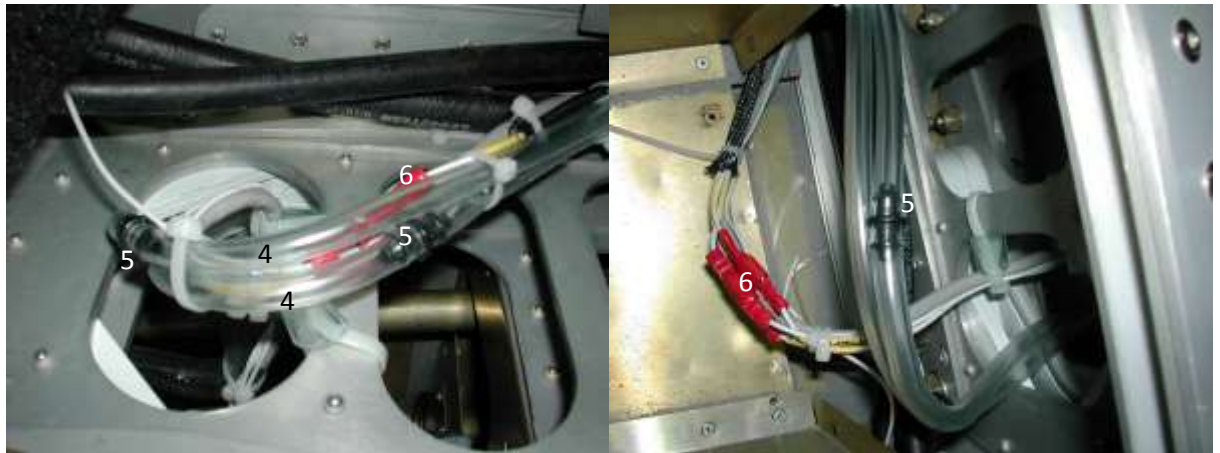



8. Disconnect the fuel quantity sensor, navigation lights and landing / taxi light wiring (6). Cut any tie wraps which would prevent the wing-side wiring from moving free of the aircraft when the wing is moved away.
9. Disconnect the flap torsion bar connector (7) from inside the fuselage by removing the two AN3 bolts (8) closest to the wing.

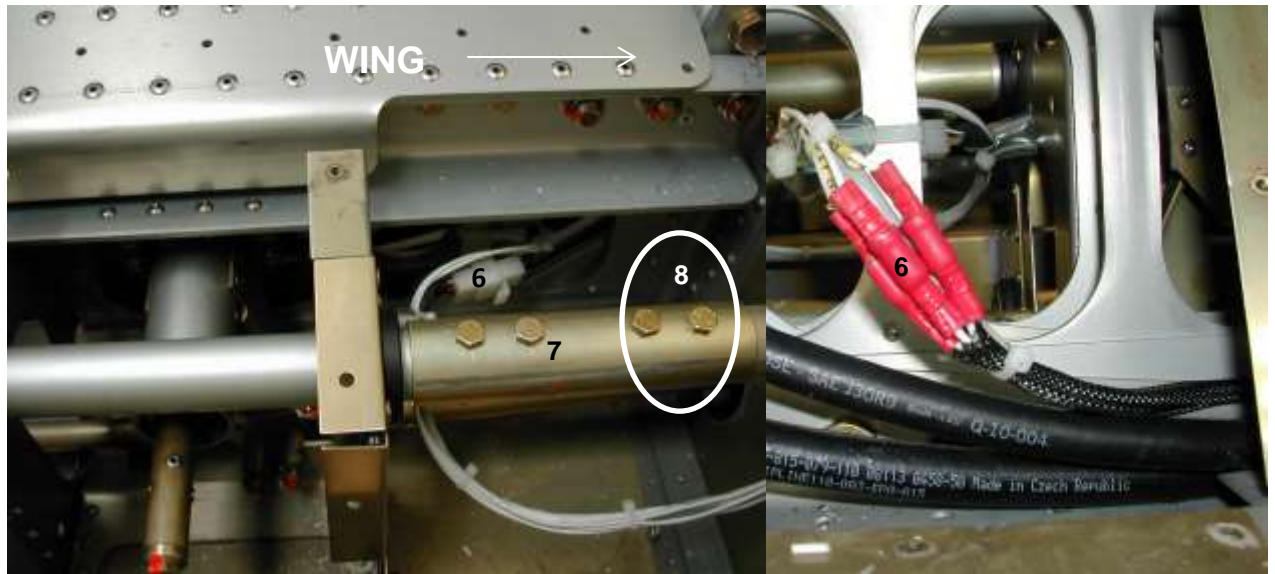

10. Disconnect the aileron pushrod (9) (inside the fuselage) by removing the AN4 bolt (10) from the rod end bearing (11).

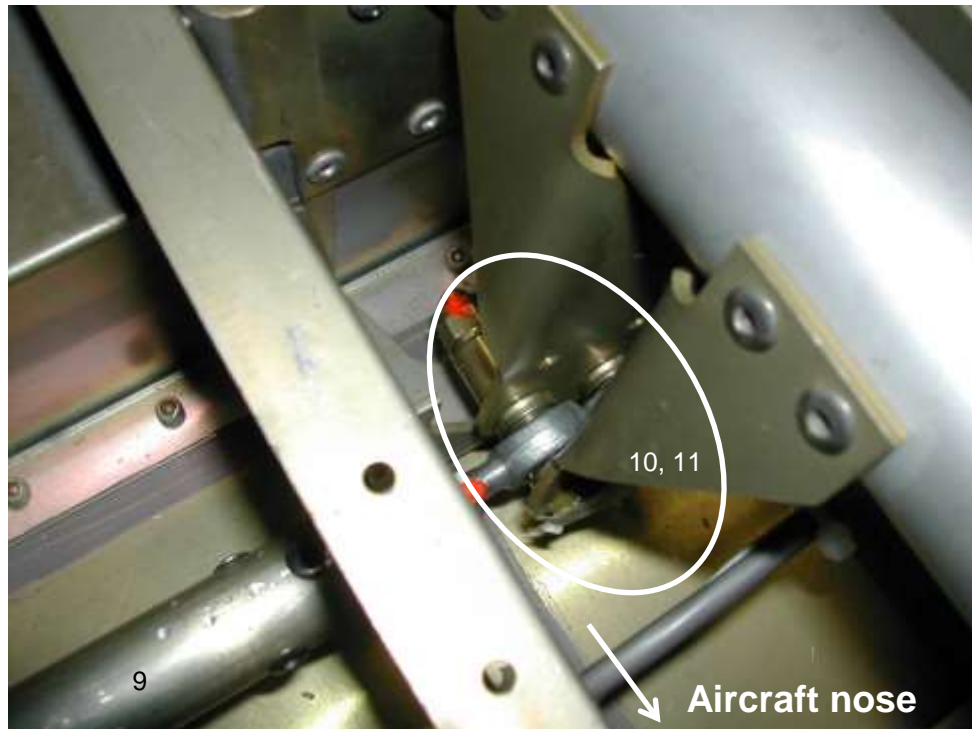

11. While supporting the wing, remove all the main spar wing retaining bolts, except for the outside top bolt and the outside bottom bolt. Remove the locknuts from the remaining two bolts in the main spar and from the bolt in the rear spar, but do not remove the bolts.
12. While supporting the wing remove the three remaining bolts and then carefully remove the wing by pulling the main spar directly out of the centre-spar. Take care not to damage the pushrod and torsion bar as they exit the fuselage.

### PROCEDURE (INSTALLATION)

1. Reverse the above procedure (removal) for reinstallation, paying close attention to the following:
  - Apply Loctite 577 on the threads of the fuel line couplings and tighten sufficiently.
  - Tighten the main (front) spar bolts to the recommended value (refer to paragraph 1.5.2). Observe the correct placement of washers (refer to Figure 5).

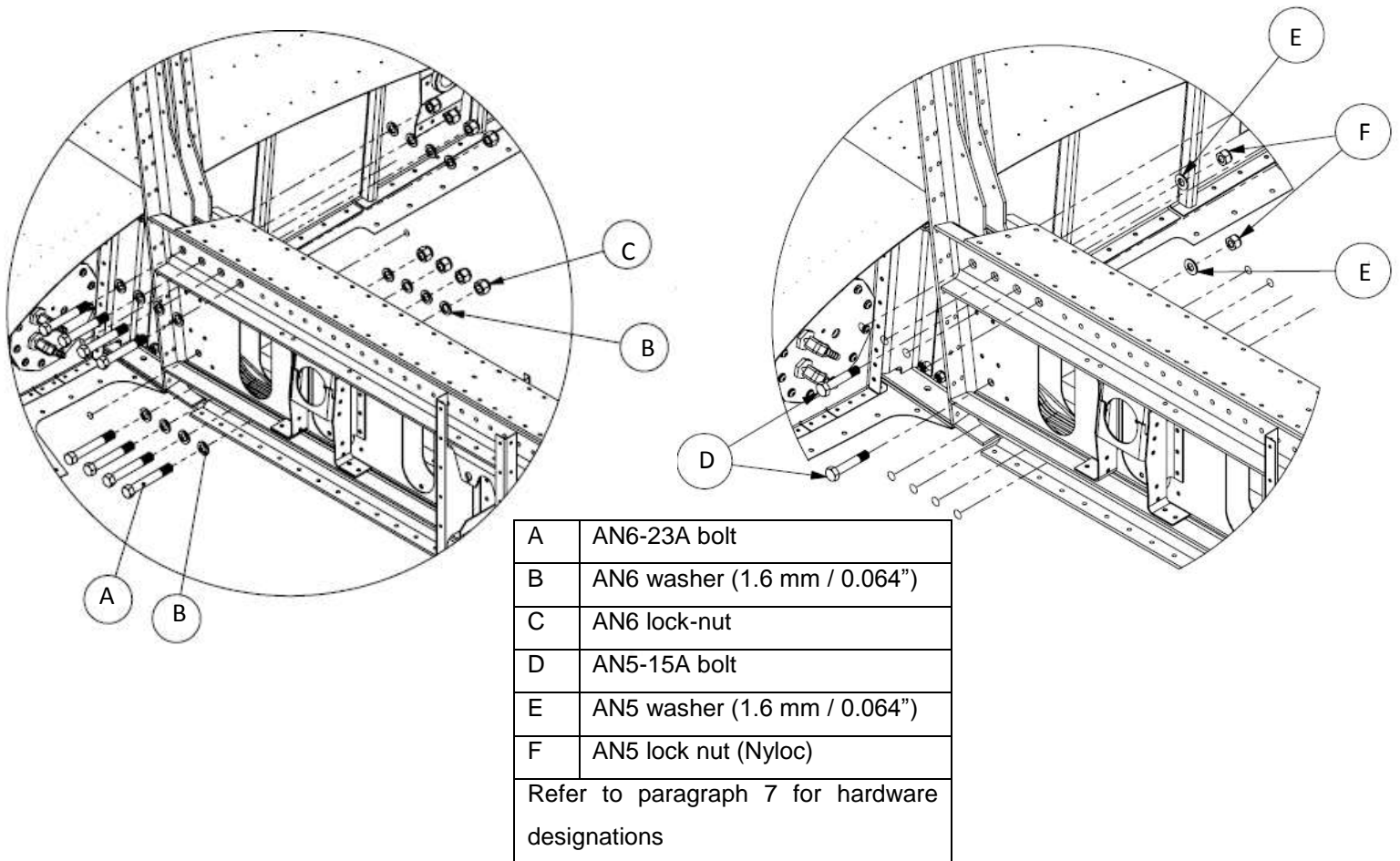

Figure 5: Front wing spar to fuselage connection.

- Tighten the rear spar bolt to the recommended value (refer to paragraph 1.5.2). Observe the correct placement of washers (refer to Figure 6).

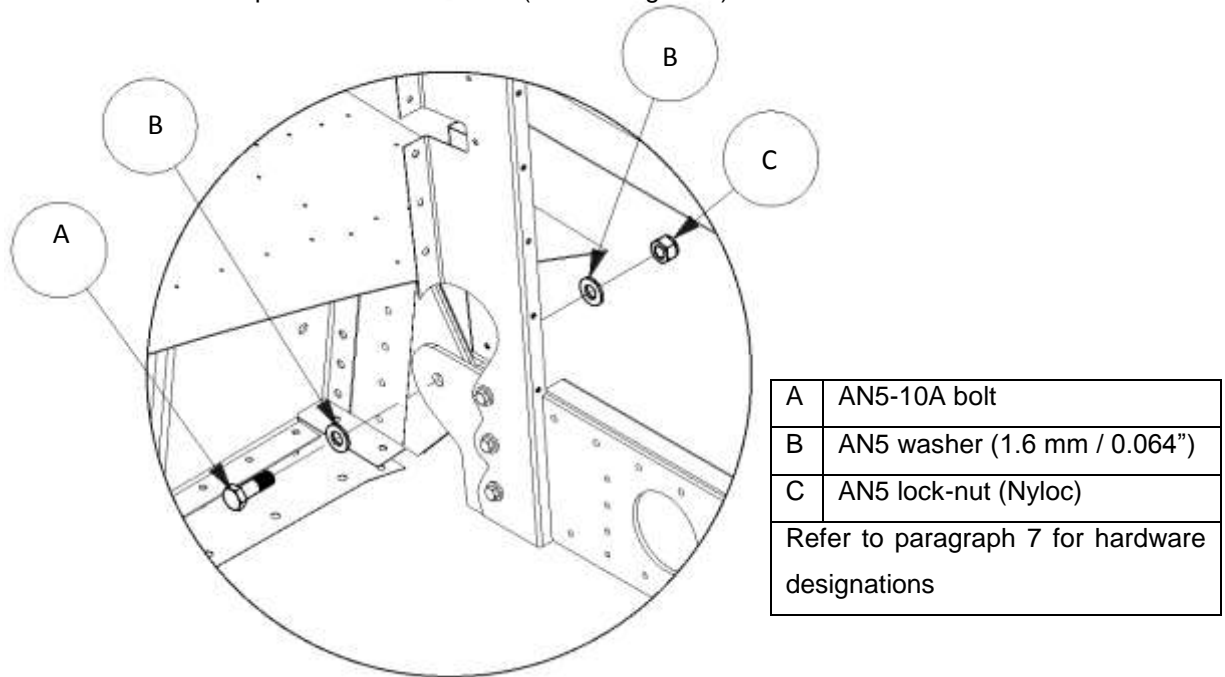

Figure 6: Rear wing spar to fuselage connection.

- Tighten the lock nut on the bolt through the aileron pushrod rod end bearing sufficiently, observe the correct placement of washers (refer to Figure 7) and note that the bolt is installed with its head facing the nose of the aircraft.

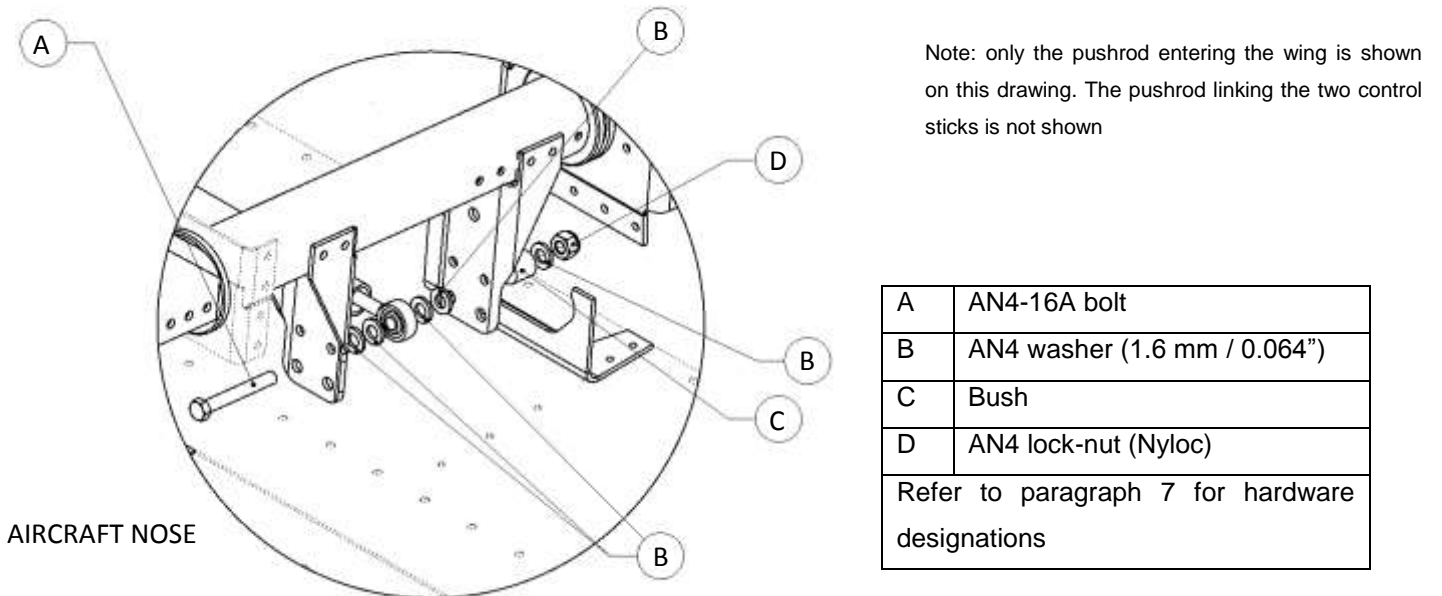

Figure 7: Aileron pushrod-to-control stick connection.

- Tighten the two AN3 lock-nuts on the bolts connecting the wing flap torsion bar sufficiently and observe the correct placement of washers.
  - Apply tie wraps as required.
2. Paint orange creep marks on the bolts and nuts.
  3. Inspect for security of attachment.
  4. Inspect for play on cables / pneumatic tubes which may cause chaffing.
  5. Before flight, verify alignment and free and correct travel for the ailerons and flaps. Refer to paragraph 1.13.
  6. Ensure that no loose objects, foreign materials or tools are left behind in the wing before closing the fuel tank inlet / outlet inspection panel.
  7. Ensure that no loose objects, foreign materials or tools are left behind under the cabin floor / seat before replacing the seat.
  8. Apply thread locking sealant to the inspection panel(s) and wing-to-fuselage fairing(s) screws before fitting.

#### 4.1.2 AILERON(S )

The aileron is a conventional stressed-skin semi-monocoque structure comprising of ribs and riveted sheet metal skin, without a spar. An aluminium tube running inside the leading edge serves as a balancing weight.

Aileron hinges (on the aileron side) comprise of sealed ball bearings pressed into shaped plates attached to the aileron.

##### 4.1.2.1 AILERON CONTROL SYSTEM

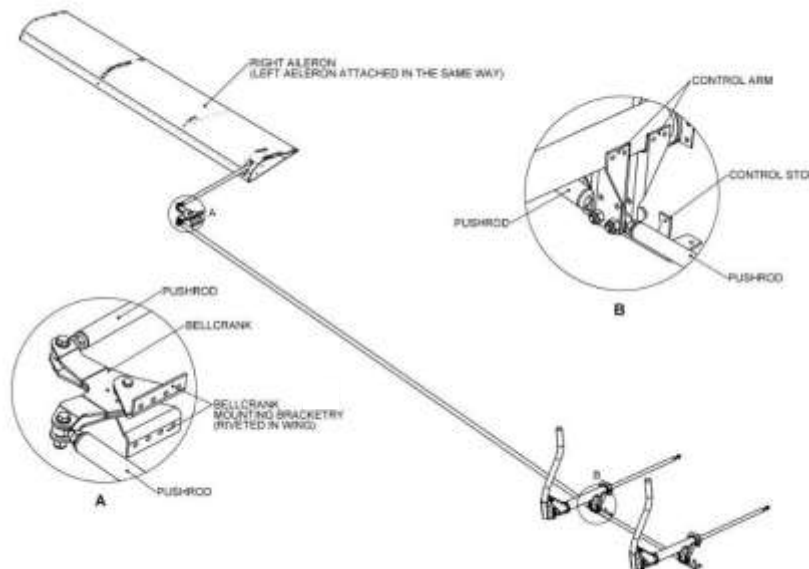

Figure 8 : Aileron control system.

Refer to Figure 8. The aileron control system uses push-pull rods and bellcranks throughout.

#### 4.1.2.2 AILERON REMOVAL / INSTALLATION

TOOLS / EQUIPMENT REQUIRED		
ITEM	QUANTITY	NOTES
1	2 mm Allen key / hex drive.	1
2	7/16 Spanner.	2
<p>The above list is not necessarily a complete list of all required tools and equipment needed. A calibrated torque wrench (with adequate range) and the correct size (as implied by the above tool list) accessories (sockets etc.) are implied for torquing bolts / nuts, if applicable. Refer to paragraph 1.5 for torque values.</p>		
CONSUMABLE MATERIAL REQUIRED		
ITEM	QUANTITY	NOTES
1	Orange paint.	As needed.
2	Loctite 222.	As needed. Inspection panel screws.
<p>The above list is not necessarily a complete list of all material needed. Refer to the Sling 2 construction manual.</p>		
AUTHORISED PERSONNEL		
<p>Any person performing maintenance of any kind on the aircraft or any component thereof must do so in accordance with national legislation. This is the responsibility of the aircraft owner and any person who is to perform any maintenance on the aircraft.</p>		

**CAUTION**

**BE PREPARED WITH A HELPER OR SUPPORT STAND TO HANDLE THE WEIGHT AND / OR AWKWARDNESS OF THE OBJECT TO BE REMOVED / INSTALLED.**

**CAUTION**

**CONTROL SURFACE WILL FALL FREE WHEN THE CONTROL LINKAGE CONNECTED TO IT IS DISCONNECTED.**

### PROCEDURE (REMOVAL)

Retain any bolts, nuts (except lock-nuts) spacers, screws and washers (with the exception of lock-washers) for reassembly.

1. Remove the aileron bellcrank (1) inspection cover (2) from the (underside of) the wing.
2. Support the aileron and unfasten and remove the bolt (3) securing the pushrod (4) to the bellcrank.

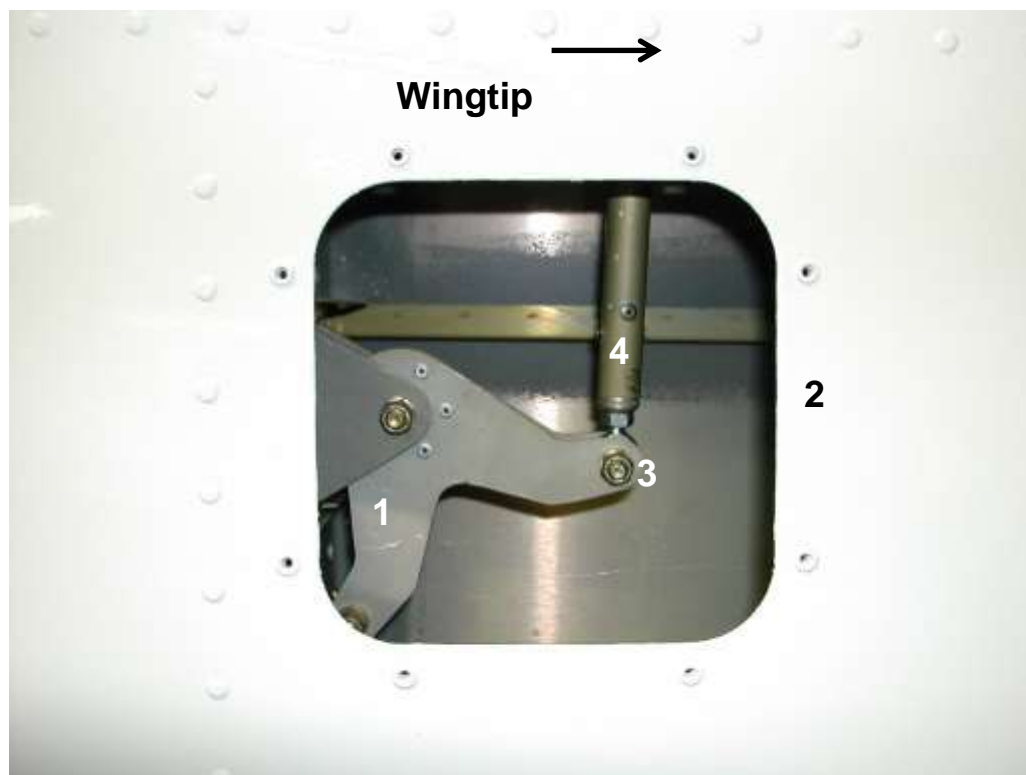

3. Support the aileron and unfasten and remove the bolts securing the aileron to the aileron hinges.
4. Carefully pull the aileron away from the aircraft and hinges, supporting and guiding the disconnected aileron pushrod as it exits the wing.

## PROCEDURE (INSTALLATION)

1. Reverse the above procedure (removal), paying close attention to the following:
  - Inspect all bolts, nuts and screws for damage. Replace if necessary.
  - Do not reuse lock-nuts. Fit new.
  - Tighten the lock-nut on the bolt through the inboard aileron hinge sufficiently, observe the correct placement of washers (refer to Figure 9) and note that the bolt is installed with its head facing the wingtip.

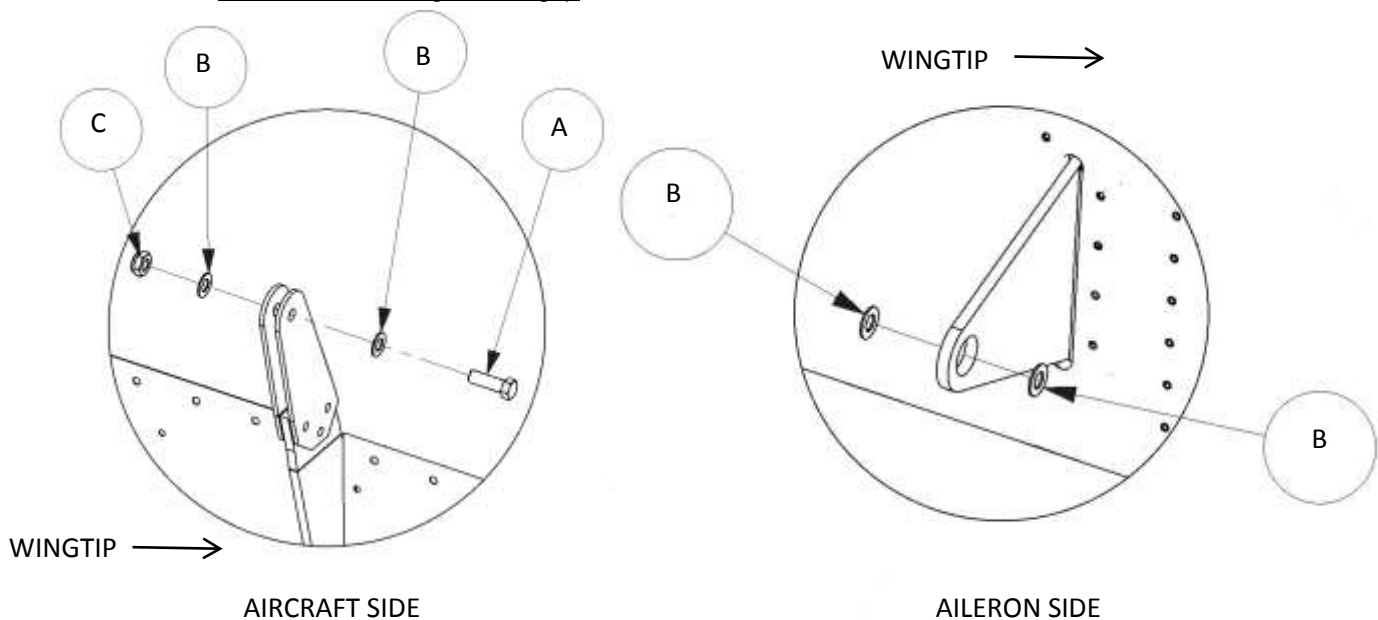

A	AN4-6A bolt
B	AN4 washer (0.8 mm / 0.032")
C	AN4 lock-nut (low profile) (Nyloc)
Refer to paragraph 7 for hardware designations	

Figure 9: Aileron hinge (inboard).



- Tighten the lock-nut on the bolt through the outboard aileron hinge sufficiently, observe the correct placement of washers (refer to Figure 10) and note that the bolt is installed with its head facing the wingtip.

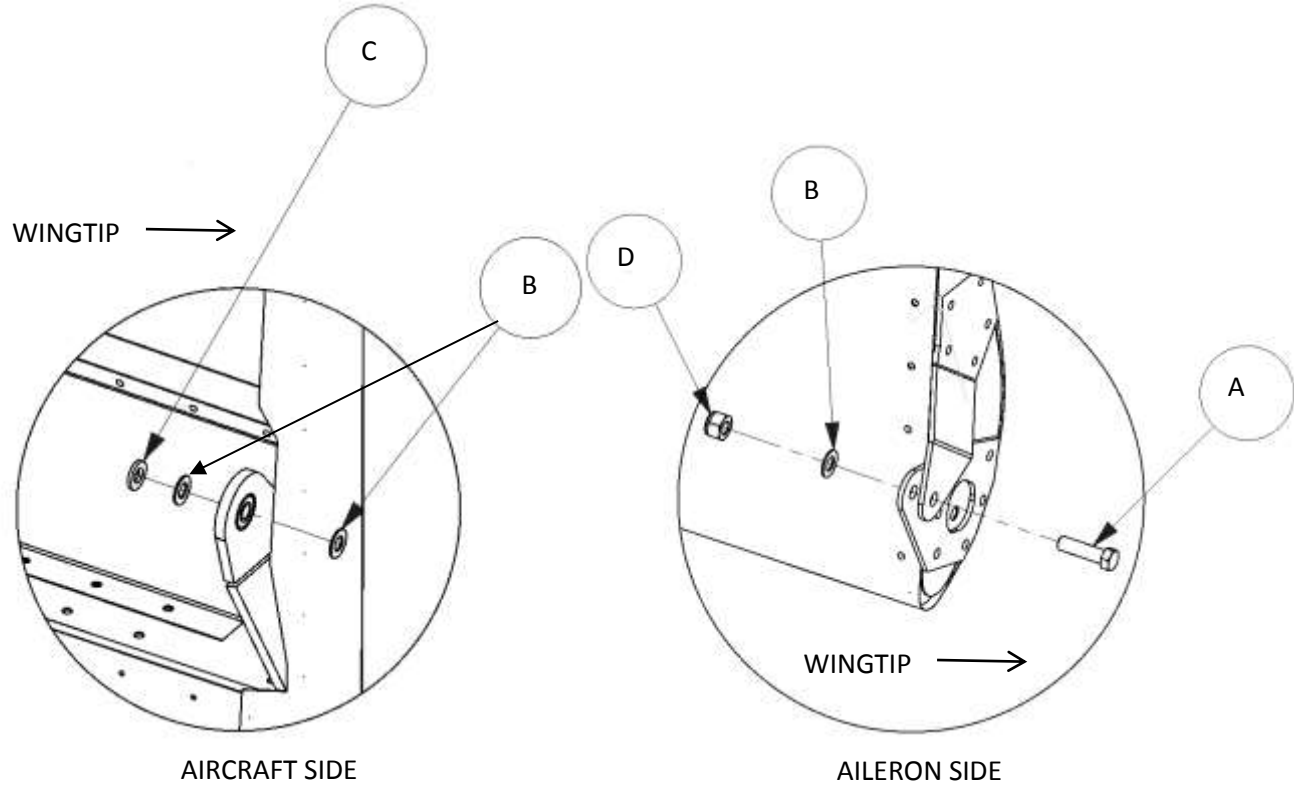

A	AN4-7A bolt
B	AN4 washer (0.8 mm / 0.032")
C	AN4 washer (1.6 mm / 0.064")
D	AN4 lock-nut (Nyloc)
Refer to paragraph 7 for hardware designations	

Figure 10: Aileron hinge (outboard).

- Tighten the lock-nut on the bolt through the aileron pushrod rod-end bearing sufficiently, observe the correct placement of washers (refer to Figure 11) and note that the bolt is installed with its head facing the wing upper surface.

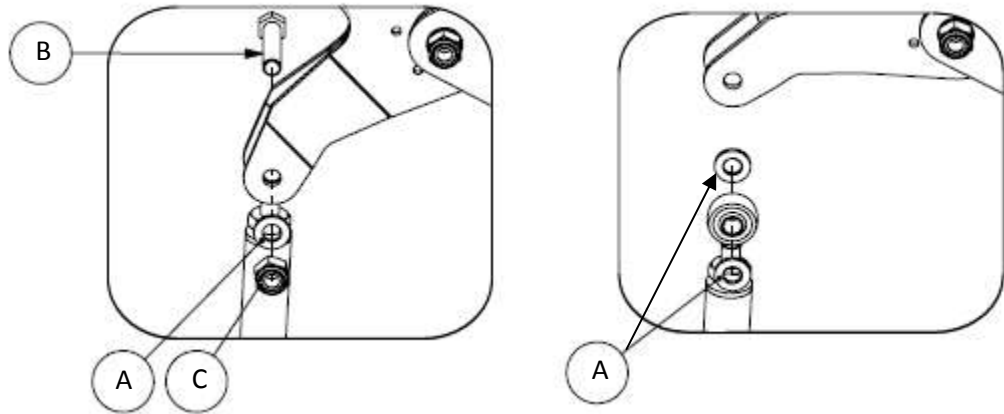

A	AN4 washer (1.6 mm / 0.064")
B	AN4-11A bolt.
C	AN4 lock-nut (Nyloc)
Refer to paragraph 7 for hardware designations	

Figure 11: Aileron pushrod -to-bellcrank connection.

2. Ensure that with the control column vertical the aileron trailing edge is aligned with wing trailing edge and that the aileron bellcrank is in the neutral position, i.e. the inside arm (the arm closest to the cabin) is perpendicular with the spar axis.
3. Verify for alignment and correct travel (refer to paragraph 1.13).
4. Apply creep marks to the bolts / nuts with orange paint.
5. Apply thread locking sealant and replace the inspection panel.

#### 4.1.2.3 AILERON ADJUSTMENT

TOOLS / EQUIPMENT REQUIRED			
ITEM		QUANTITY	NOTES
1	7/16 Spanner.	1	
2	2 mm Allen key.	1	
3	Straight edge.	1	
The above list is not necessarily a complete list of all required tools and equipment needed. A calibrated torque wrench (with adequate range) and the correct size (as implied by the above tool list) accessories (sockets etc.) are implied for torquing bolts / nuts, if applicable. Refer to paragraph 1.5 for torque values.			
CONSUMABLE MATERIAL REQUIRED			
ITEM		QUANTITY	NOTES
1	Orange paint.	As needed.	
2	Loctite 222.	As needed.	Inspection panel screws.
The above list is not necessarily a complete list of all material needed. Refer to the Sling 2 construction manual.			
AUTHORISED PERSONNEL			
Any person performing maintenance of any kind on the aircraft or any component thereof must do so in accordance with national legislation. This is the responsibility of the aircraft owner and any person who is to perform any maintenance on the aircraft.			

## PROCEDURE

The procedure is identical for both ailerons.

1. Remove the seat(s). Refer to paragraph 4.3.2.1.
2. Remove the bellcrank inspection panel(s) under the wing(s).
3. Ensure that the control sticks move freely left and right. If the autopilot roll (aileron) servo is attached it will create some resistance. Without it attached the control sticks must move freely with negligible resistance.
4. Loosen the lock-nuts and turn the small connecting pushrod (1) in or out so that with the left stick completely vertically, the right hand stick is also completely vertical.

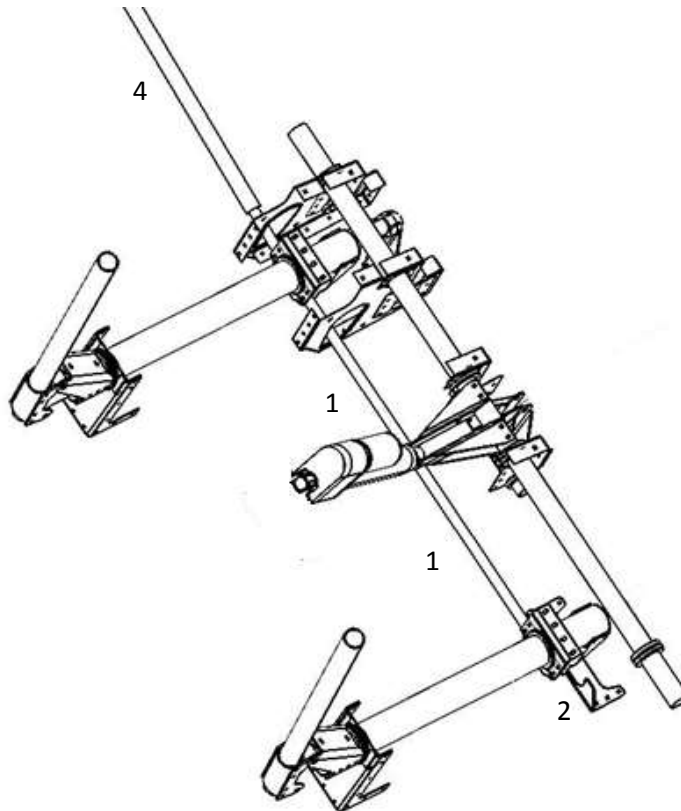

Figure 12: Aileron adjustment - cabin side.

5. Test the stops (2) so that when moving the sticks left the stops for both sticks touch simultaneously and when moving the sticks right the stops for both sticks touch simultaneously.
6. Tighten the lock-nuts on both ends of the joining pushrod (1) without turning the pushrod.
7. Loosen the lock-nuts on the long in-wing pushrod (4). Hold both sticks completely vertical and line up the bellcrank (3) by turning the main long in-wing pushrod (4) in or out until the bellcrank is exactly 90° to the pushrod (4) and lines up exactly with the edges of the inspection hatch. Use a straight edge to help with alignment.

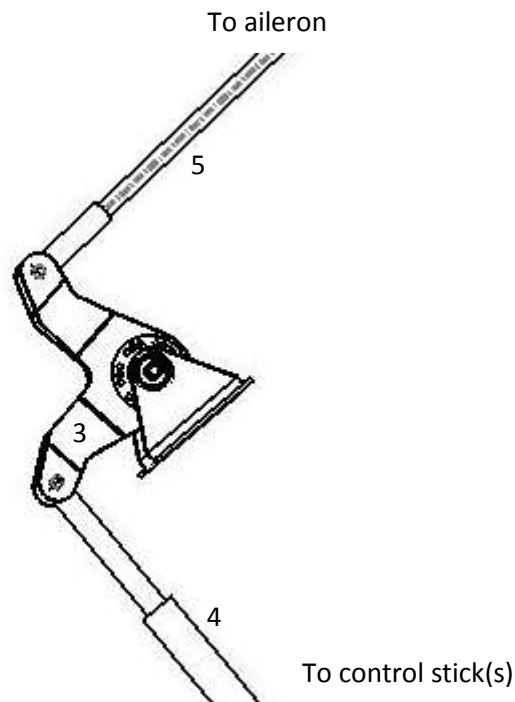

Figure 13: Aileron adjustment - wing side.

8. Tighten the lock-nuts at both ends of the main long in-wing pushrod (4) without turning the pushrod.
9. Verify again that when the sticks are vertical the bellcrank lines up with the edge of the inspection hatch.
10. Loosen the lock-nuts on the small aileron pushrod (5). While holding the sticks in the centre vertical position, screw the small aileron pushrod (5) in or out until the aileron lines up with the flap and the wingtip.
11. Tighten the lock-nuts of the small aileron pushrod (5) without turning the pushrod.
12. Verify correct aileron travel (refer to paragraph 1.13).

13. Paint orange creep marks on the pushrod lock-nuts.
14. Ensure that no tools and / or foreign materials remain in the wing and under the seats. Apply thread locking sealant to the inspection panel screws and close the panels.
15. Fit the front seat(s).

#### 4.1.2.4 AILERON AUTOPILOT SERVO REMOVAL / INSTALLATION

TOOLS / EQUIPMENT REQUIRED			
ITEM		QUANTITY	NOTES
1	3/8 Spanner.	2	
2	4 mm Allen key.	1	
3	Flat screwdriver.	1	
The above list is not necessarily a complete list of all required tools and equipment needed. A calibrated torque wrench (with adequate range) and the correct size (as implied by the above tool list) accessories (sockets etc.) are implied for torquing bolts / nuts, if applicable. Refer to paragraph 1.5 for torque values.			
CONSUMABLE MATERIAL REQUIRED			
ITEM		QUANTITY	NOTES
1	Orange paint.	As needed.	
2	Loctite 243.	As needed.	Servo mounting screws.
3	Tie wraps.	As needed.	
The above list is not necessarily a complete list of all material needed. Refer to the Sling 2 construction manual.			
AUTHORISED PERSONNEL			
Any person performing maintenance of any kind on the aircraft or any component thereof must do so in accordance with national legislation. This is the responsibility of the aircraft owner and any person who is to perform any maintenance on the aircraft.			

**WARNING**

**ENSURE MASTER AND ELECTRICAL EQUIPMENT SWITCHES ARE OFF.  
IT MAY BE EXPEDIENT TO DISCONNECT THE BATTERY GROUND TERMINAL WHILE WORKING ON  
ELECTRICAL EQUIPMENT.**

**CAUTION**

**BE PREPARED WITH A HELPER OR SUPPORT STAND TO HANDLE THE WEIGHT  
AND / OR AWKWARDNESS OF THE OBJECT (SEAT) TO BE REMOVED.**

## PROCEDURE (REMOVAL)

Retain any bolts, nuts (except lock-nuts) spacers, screws and washers (with the exception of lock-washers) for reassembly.

1. Remove the port seat (refer to paragraph 4.3.2.1).
2. Undo the bolt (1) connecting the servo (2) control arm to the pushrod (3).

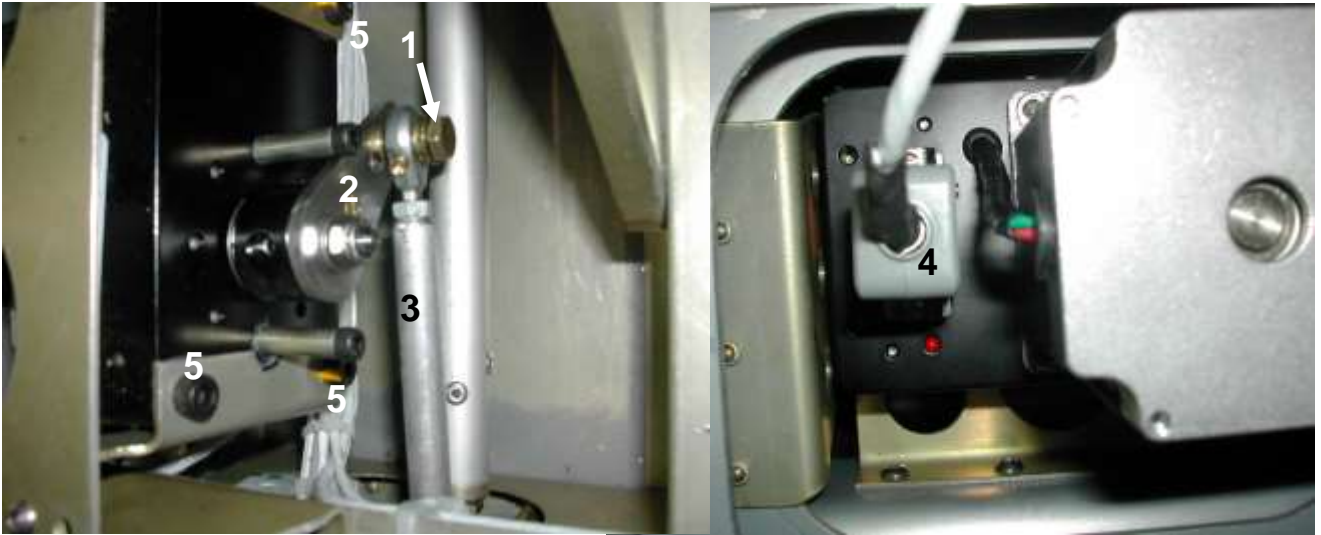

3. Unscrew the screws retaining the connector (4) to the servo and disconnect it.
4. Undo the screws (5) retaining the servo to the fuselage structure and remove the servo motor.

## PROCEDURE (INSTALLATION)

1. Reverse the above procedure (removal), paying close attention to the following:
  - Inspect all bolts, nuts and screws for damage. Replace if necessary.
  - Do not reuse lock-nuts. Fit new.



- The signal cable connector must be secured to the servo motor before installing the motor, otherwise there may not be enough space to insert and manipulate a tool to tighten the connector securing screws.
- Observe the correct placement of washers (refer to Figure 14).

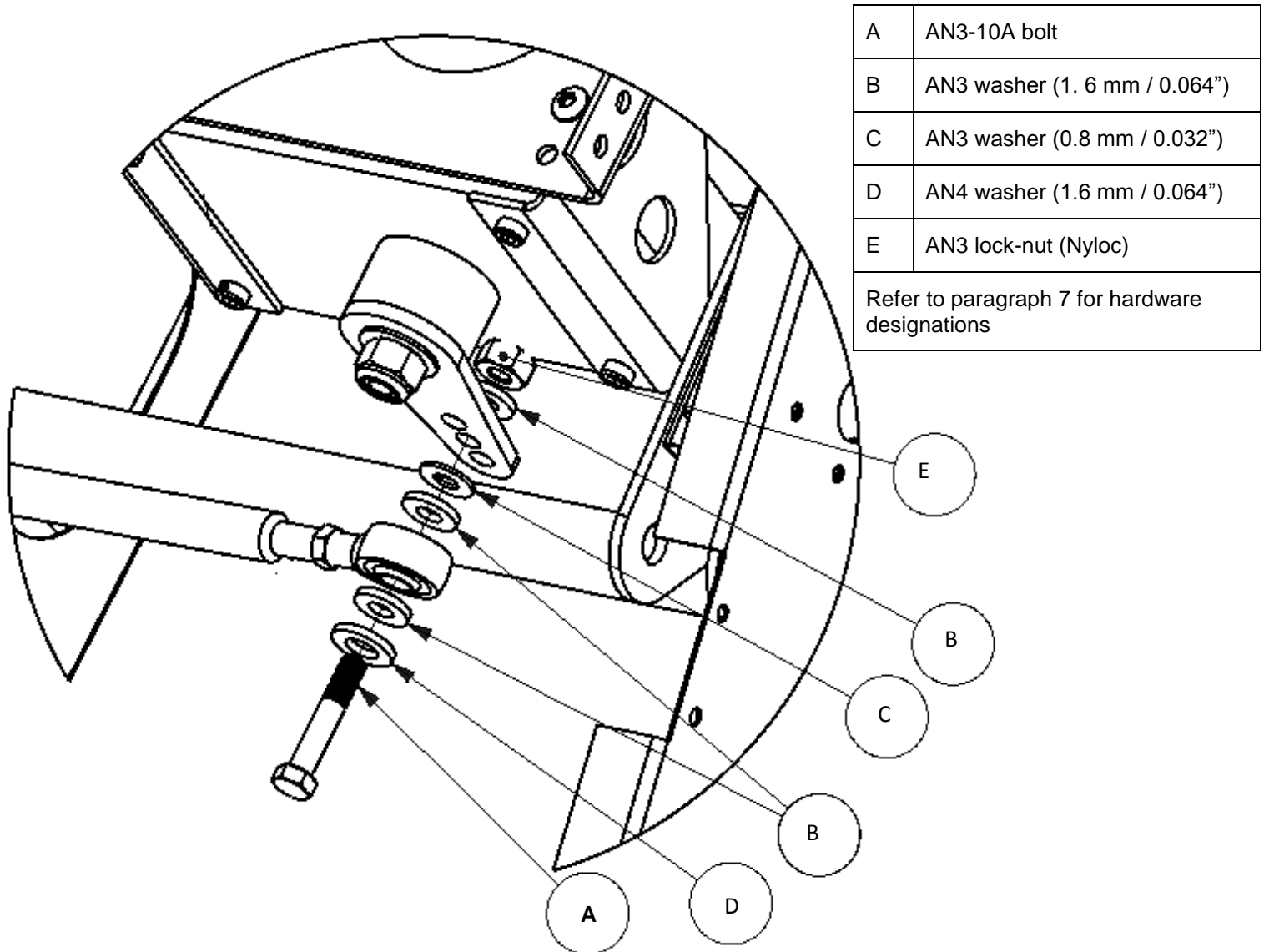

Figure 14: Autopilot aileron servo installation.

- Paint orange creep marks on the bolts / lock-nuts.
- Apply thread locking sealant to the servo mounting screws before fitting.
- Secure the cable to the aircraft frame with tie wraps, in the manner it was before removal, using spacers as applicable.

2. Ensure the applicable aircraft control(s) is (are) free and does not bind with the servo installed.
3. Follow any applicable procedures in the latest revision of the MGL Avionics EFIS integrated autopilot user and installation manual to complete installation of the servo.
4. Before flight, test the servo for correct operation (refer to the latest revision of the MGL Avionics EFIS integrated autopilot user and installation manual).

### 4.1.3 FLAPS

A flap comprises a conventional stressed-skin semi-monocoque structure comprising ribs and riveted sheet metal skin, without a spar. Flap hinges (on the aileron side) comprise of sealed ball bearings pressed into shaped plates attached to the flaps.

#### 4.1.3.1 FLAP CONTROL SYSTEM

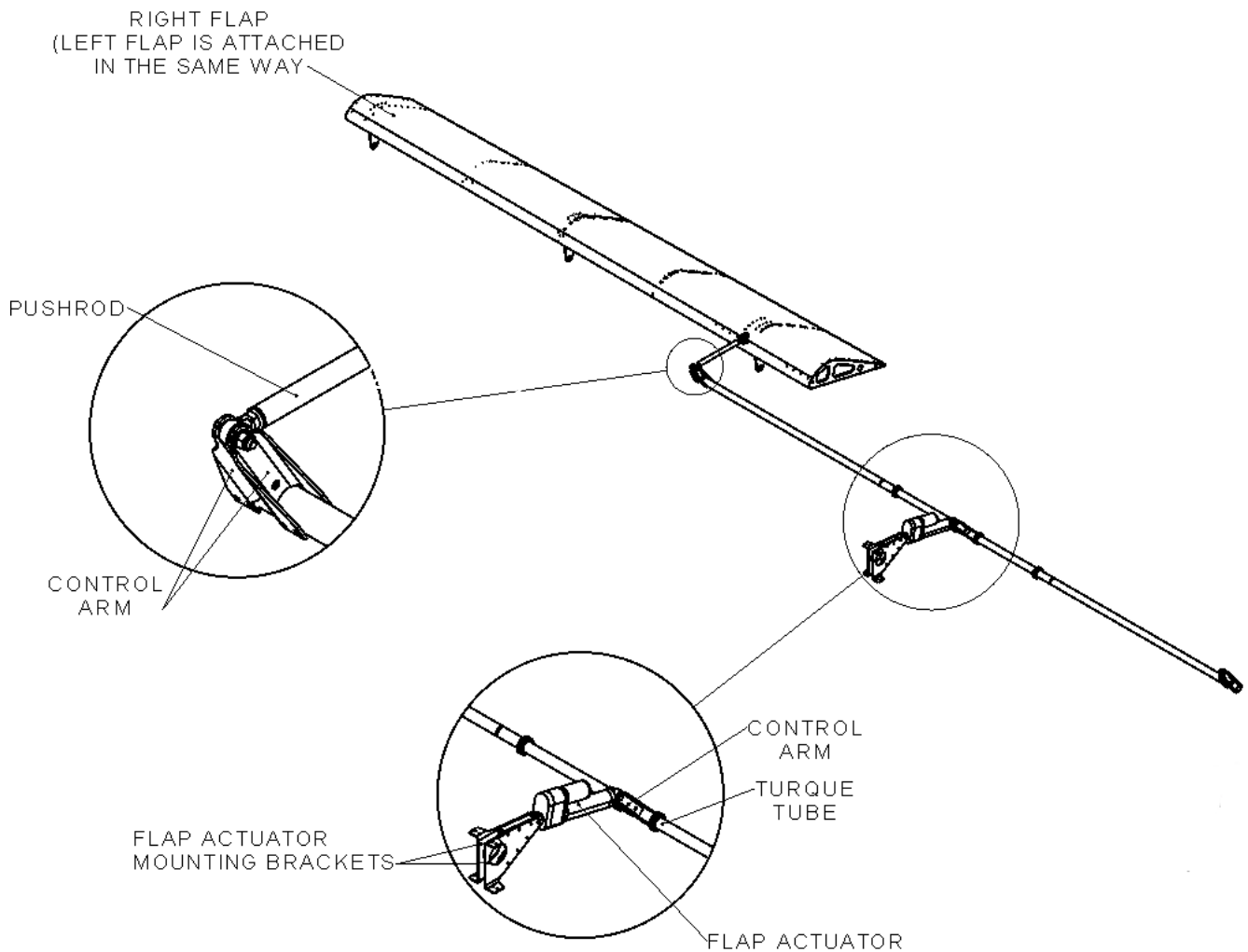

Figure 15: Flap control system.

Refer to Figure 15. The flap control system is push-pull type with a linking torque tube (torsion bar). An actuator motor is installed in the centre channel between the seats. It controls an arm attached to a torque tube. Control arms are connected to each extremity of the torque tube. Each control arm is connected to a pushrod, which in turn is connected to a wing flap.

Micro-switches positioned within the actuator motor automatically interrupt the electric current when the flaps reach extreme (up/down) positions, shutting off the actuator motor. The flap controller is located on the instrument panel.

**4.1.3.2 FLAP REMOVAL / INSTALLATION**

TOOLS / EQUIPMENT REQUIRED		
ITEM	QUANTITY	NOTES
1	2 mm Allen key.	1
2	7/16 Spanner.	2
The above list is not necessarily a complete list of all required tools and equipment needed. A calibrated torque wrench (with adequate range) and the correct size (as implied by the above tool list) accessories (sockets etc.) are implied for torquing bolts / nuts, if applicable. Refer to paragraph 1.5 for torque values.		
CONSUMABLE MATERIAL REQUIRED		
ITEM	QUANTITY	NOTES
1	Orange paint.	As needed.
2	Loctite 222.	As needed.
The above list is not necessarily a complete list of all material needed. Refer to the Sling 2 construction manual.		
AUTHORISED PERSONNEL		
Any person performing maintenance of any kind on the aircraft or any component thereof must do so in accordance with national legislation. This is the responsibility of the aircraft owner and any person who is to perform any maintenance on the aircraft.		

**CAUTION**  
**BE PREPARED WITH A HELPER OR SUPPORT STAND TO HANDLE THE WEIGHT  
AND / OR AWKWARDNESS OF THE OBJECT TO BE REMOVED**

**CAUTION**  
**CONTROL SURFACE WILL ROTATE / FALL FREE WHEN THE CONTROL LINKAGE CONNECTED TO IT  
IS DISCONNECTED.**

### PROCEDURE (REMOVAL) (OPTION 1)

Retain any bolts, nuts (except lock-nuts) spacers, screws and washers (with the exception of lock-washers) for reassembly.

1. Extend the flaps fully.
2. Disconnect the bolt (1) attaching the flap pushrod (2) the flap (3).

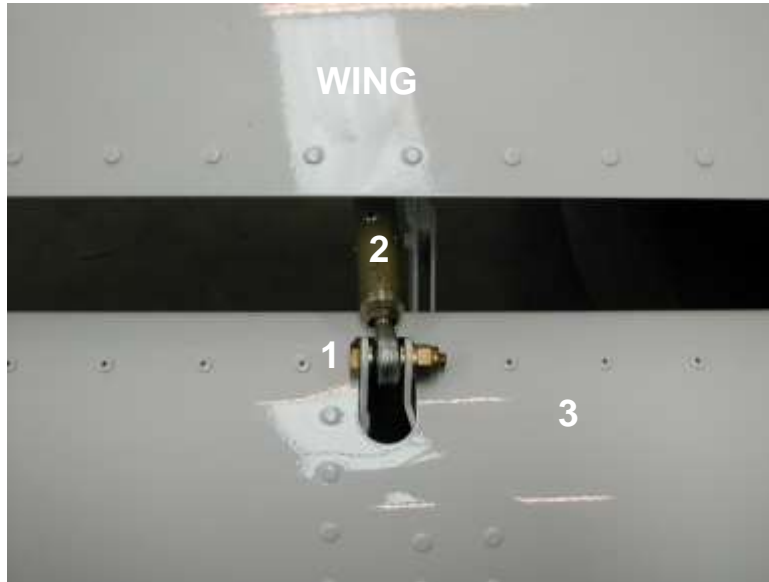

3. Support the flap and remove the bolts, washers and locknuts (4) from the hinges (5).

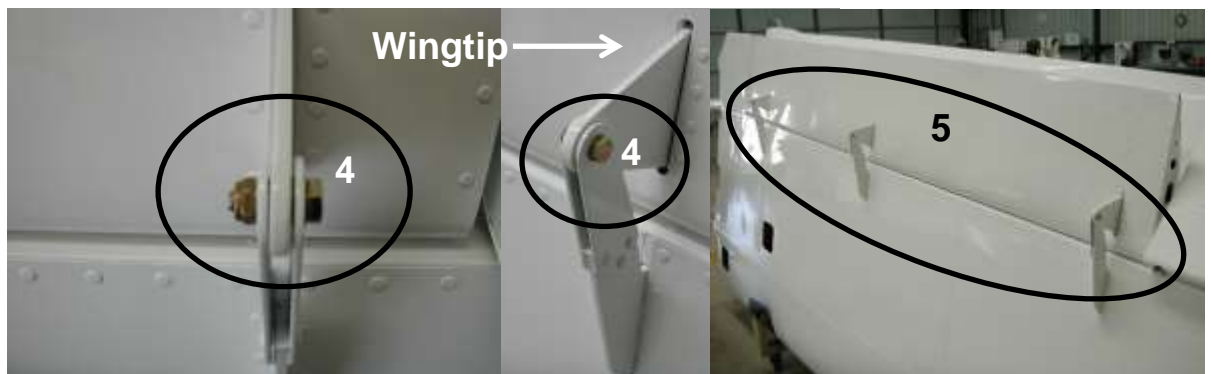

4. Support the disconnected pushrod and carefully pull the flap away from the wing and the hinges.

**PROCEDURE (INSTALLATION) (OPTION 1)**

1. Reverse above procedure (removal), paying close attention to the following:
  - Inspect all bolts, nuts and screws for damage. Replace if necessary.
  - Do not reuse lock-nuts. Fit new.
  - Tighten the lock-nuts on the bolts through the flap hinges sufficiently, observe the correct placement of washers (refer to Figure 16) and note that the bolts are installed with their heads facing the wingtip.

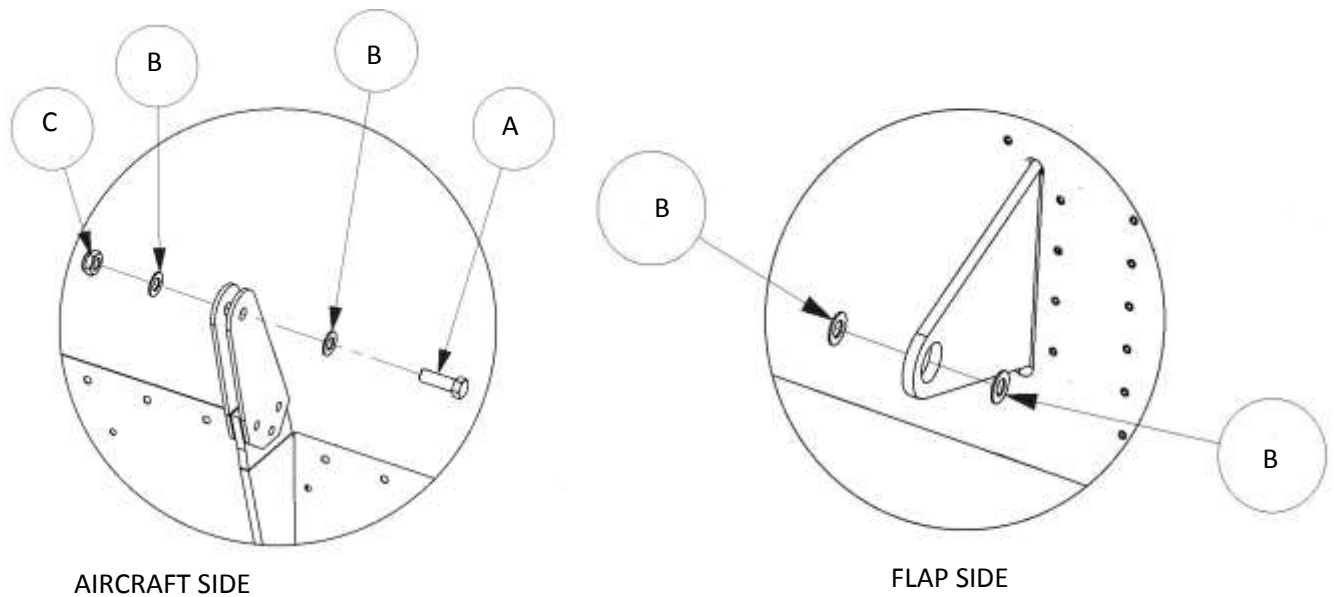

A	AN4-6A bolt
B	AN4 washer (0.8 mm / 0.064")
C	AN4 lock-nut (low profile) (Nyloc)
Refer to paragraph 7 for hardware designations	

Figure 16: Flap hinges.

- Tighten the lock nut on the bolt through the flap pushrod rod end bearing sufficiently, observe the correct placement of washers (refer to Figure 17) and note that the bolt is installed with its head facing the wingtip.

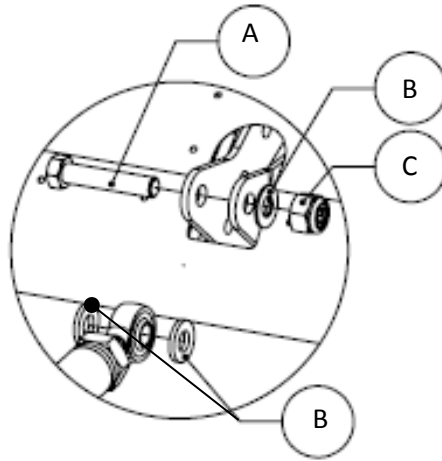

A	AN4-11A bolt
B	AN4 washer (1.6 mm / 0.064")
C	AN4 lock-nut (Nyloc)
Refer to paragraph 7 for hardware designations	

Figure 17: Flap pushrod-to-flap connection.

2. Verify the flap for alignment and correct travel (refer to paragraph 1.13).
3. Paint orange creep marks on the bolts / nuts.

## PROCEDURE (REMOVAL) (OPTION 2)

Retain any bolts, nuts (except lock-nuts) spacers, screws and washers (with the exception of lock-washers) for reassembly.

1. Remove the flap inspection cover (1) from the (underside of) the wing.
2. Support the flap and disconnect the bolt (2) connecting the flap pushrod (3) to the flap torque tube (4) control arm.



3. Support the flap and remove the bolts, washers and locknuts from the hinges.
4. Carefully pull the flap away from the aircraft and hinges, supporting and guiding the disconnected flap pushrod as it exits the wing.



## PROCEDURE (INSTALLATION) (OPTION 2)

1. Reverse above procedure (removal)(option 2), paying close attention to the following:

- Inspect all bolts, nuts and screws for damage. Replace if necessary.
- Do not reuse lock-nuts. Fit new.
- Tighten the lock-nuts on the bolts through the flap hinges sufficiently, observe the correct placement of washers (refer to Figure 16) and note that the bolts are installed with their heads facing the wingtip.
- Tighten the lock nut on the bolt through the flap pushrod rod end bearing sufficiently, observe the correct placement of washers (refer to Figure 18) and note that the bolt is installed with its head facing the wingtip.

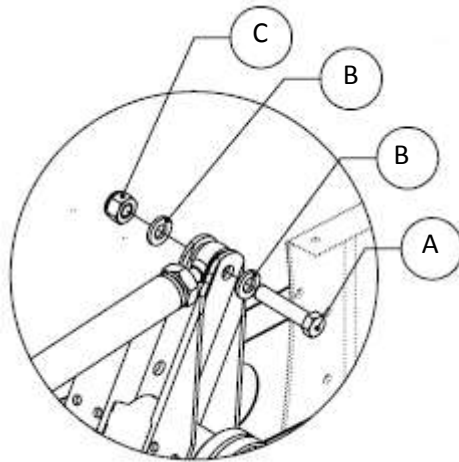

A	AN4-11A bolt
B	AN4 washer (1.6 mm / 0.064")
C	AN4 lock-nut(Nyloc)
Refer to paragraph 7 for hardware designations	

Figure 18: Flap pushrod-to-flap torque tube control arm connection.

2. Verify the flap for alignment and correct travel (refer to paragraph 1.13).
3. Paint orange creep marks on the bolts / nuts.
4. Apply thread locking sealant to the screws and replace the flap inspection panel. Insure no tools or foreign materials are left inside the wing before closing the panel.

### 4.1.3.3 FLAP ADJUSTMENT

TOOLS / EQUIPMENT REQUIRED		
ITEM	QUANTITY	NOTES
1	2 mm Allen key.	Option 2 only.
2	7/16 Spanner.	
The above list is not necessarily a complete list of all required tools and equipment needed. A calibrated torque wrench (with adequate range) and the correct size (as implied by the above tool list) accessories (sockets etc.) are implied for torquing bolts / nuts, if applicable. Refer to paragraph 1.5 for torque values.		
CONSUMABLE MATERIAL REQUIRED		
ITEM	QUANTITY	NOTES
1	Orange paint.	As needed.
2	Loctite 222.	Inspection panel screws.
The above list is not necessarily a complete list of all material needed. Refer to the Sling 2 construction manual.		
AUTHORISED PERSONNEL		
Any person performing maintenance of any kind on the aircraft or any component thereof must do so in accordance with national legislation. This is the responsibility of the aircraft owner and any person who is to perform any maintenance on the aircraft.		

### PROCEDURE

The procedure is identical for the port and starboard flaps.

1. Flaps retracted to full up position.
2. Take a straight edge and place it flat underneath the wing against the 3rd hinge bracket (from the root) and along the rib rivets (but not on the rivets). If correctly adjusted the flap should just touch the straight edge.
3. To adjust, remove the flap inspection panel under the wing, lower the flaps and undo the locknuts on both end of the flap pushrod. Retract the flaps.
4. Take the straight edge and place it flat underneath the wing against the 3rd hinge bracket (from the root) and along the rib rivets (but not on the rivets). Clamp the straight edge to the bracket in this position, such that it stays flat underneath the wing.
5. Turn the pushrod until the flap just touches the straight edge.
6. Remove the straight edge.
7. Lower the flaps to gain access to the flap side pushrod connection.

8. Tighten the locknuts on both ends of the flap pushrods without turning the pushrods.
9. Paint orange creep marks on the pushrod lock-nuts.
10. Verify (before flight) correct travel for the flap (refer to paragraph 1.13).
11. Ensure that no foreign material or tools remain inside the wing, apply thread locking sealant to the flap inspection panel screws and fit the panel. Do not over tighten the screws.

**4.1.3.4 FLAP ACTUATOR MOTOR REMOVAL / INSTALLATION**

TOOLS / EQUIPMENT REQUIRED			
ITEM		QUANTITY	NOTES
1	2.5 mm Allen key / hex driver	1	
2	½ inch Spanner.	2	
3	2 mm Allen key / hex driver.	1	
The above list is not necessarily a complete list of all required tools and equipment needed. A calibrated torque wrench (with adequate range) and the correct size (as implied by the above tool list) accessories (sockets etc.) are implied for torquing bolts / nuts, if applicable. Refer to paragraph 1.5 for torque values.			
CONSUMABLE MATERIAL REQUIRED			
ITEM		QUANTITY	NOTES
1	Split pin.	2	
2	Loctite 222.	As needed.	Inspection panel screws.
3	Tie wraps.	As needed.	Actuator cable.
The above list is not necessarily a complete list of all material needed. Refer to the Sling 2 construction manual.			
AUTHORISED PERSONNEL			
Any person performing maintenance of any kind on the aircraft or any component thereof must do so in accordance with national legislation. This is the responsibility of the aircraft owner and any person who is to perform any maintenance on the aircraft.			

**CAUTION**  
**CONTROL SURFACE WILL ROTATE / FALL FREE WHEN THE CONTROL LINKAGE CONNECTED TO IT IS DISCONNECTED.**

**WARNING**  
**ENSURE MASTER AND ELECTRICAL EQUIPMENT SWITCHES ARE OFF.**  
**IT MAY BE EXPEDIENT TO DISCONNECT THE BATTERY GROUND TERMINAL WHILE WORKING ON ELECTRICAL EQUIPMENT.**

**CAUTION**  
**BE PREPARED WITH A HELPER OR SUPPORT STAND TO HANDLE THE WEIGHT AND / OR AWKWARDNESS OF THE OBJECT (SEAT) TO BE REMOVED.**

## PROCEDURE (REMOVAL)

Retain any bolts, nuts (except lock-nuts) spacers, screws and washers (with the exception of lock-washers) for reassembly.

1. Remove the pilot seat (refer to paragraph 4.3.2.1).
2. Remove the central side panel under the instrument panel (next to pilot's legs / calves) to gain access to the flap actuator motor's signal cable plug. Disconnect the plug. Remove tie wraps where necessary.
3. Remove the central console panel (next to the front seat) by loosening the button head screws retaining it.
4. Support the flap actuator motor (1) and undo the bolts (2) retaining the motor to the forward fuselage bracket (3) and the flap torque tube (4) control arm (5). Be aware that the flaps will fall / rotate down unless supported.

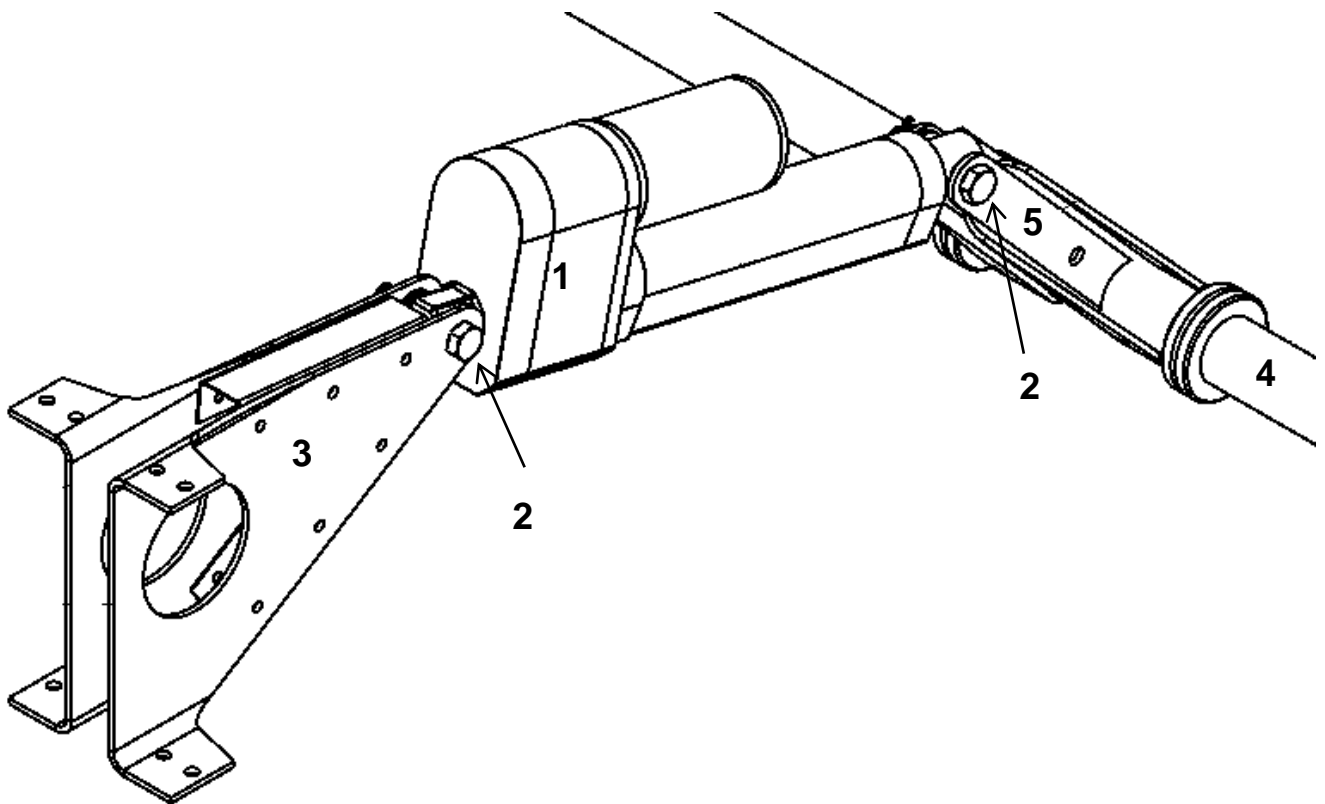

Figure 19: Flap actuator motor removal.

## PROCEDURE (INSTALLATION)

1. Reverse above procedure (removal), paying close attention to the following:
  - Inspect all bolts, nuts and screws for damage. Replace if necessary.
  - Do not reuse split pins. Fit new.
  - Observe correct placement of washers (refer to Figure 20).

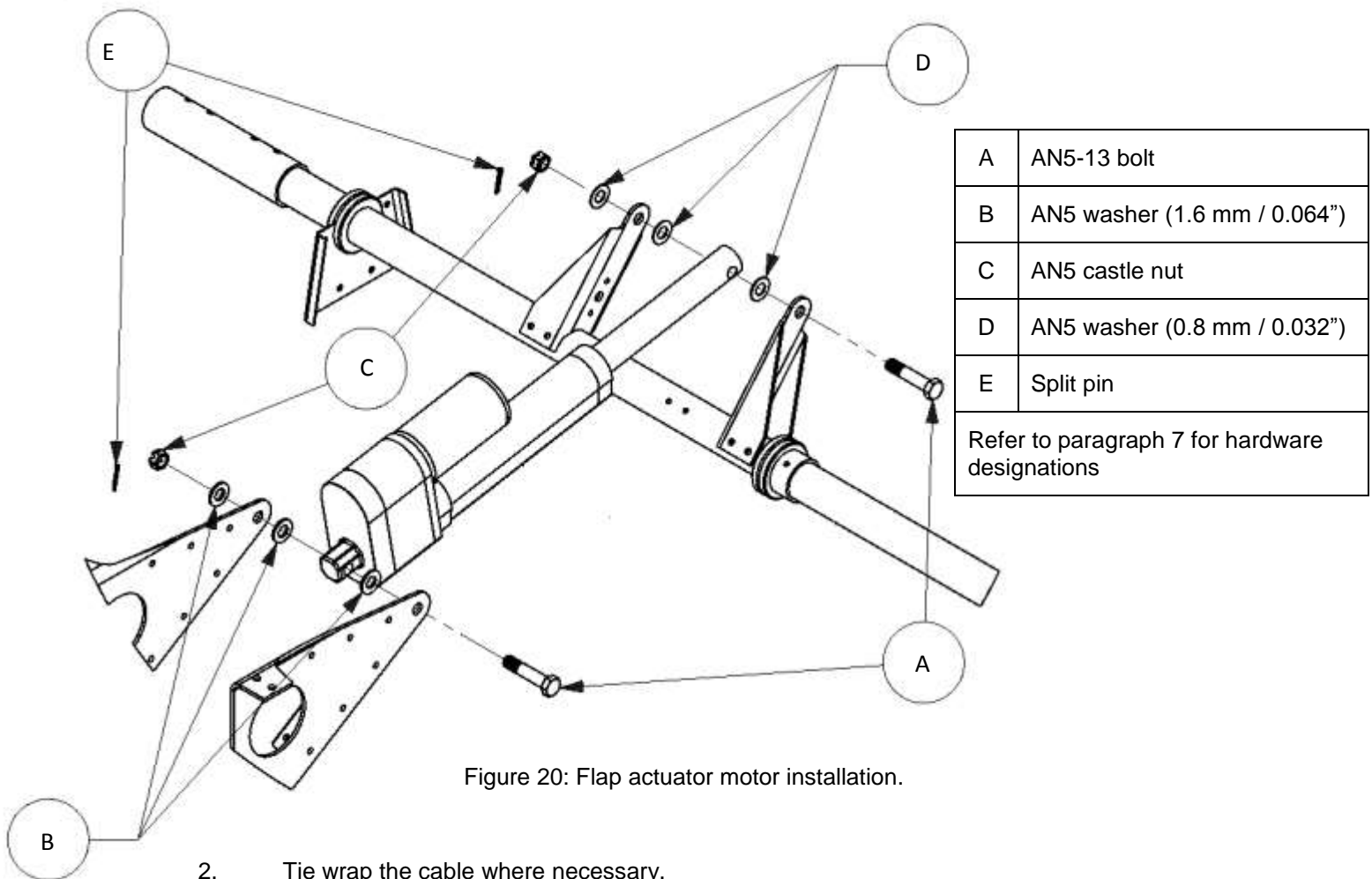

Figure 20: Flap actuator motor installation.

2. Tie wrap the cable where necessary.
3. Verify alignment and correct flap movement (refer to paragraph 1.13) before closing up the centre console and before flight.
4. Apply thread locking sealant to the inspection panel screws before fitment. Do not over tighten.

## 4.2 EMPENNAGE

### 4.2.1 HORIZONTAL TAIL AND ELEVATOR

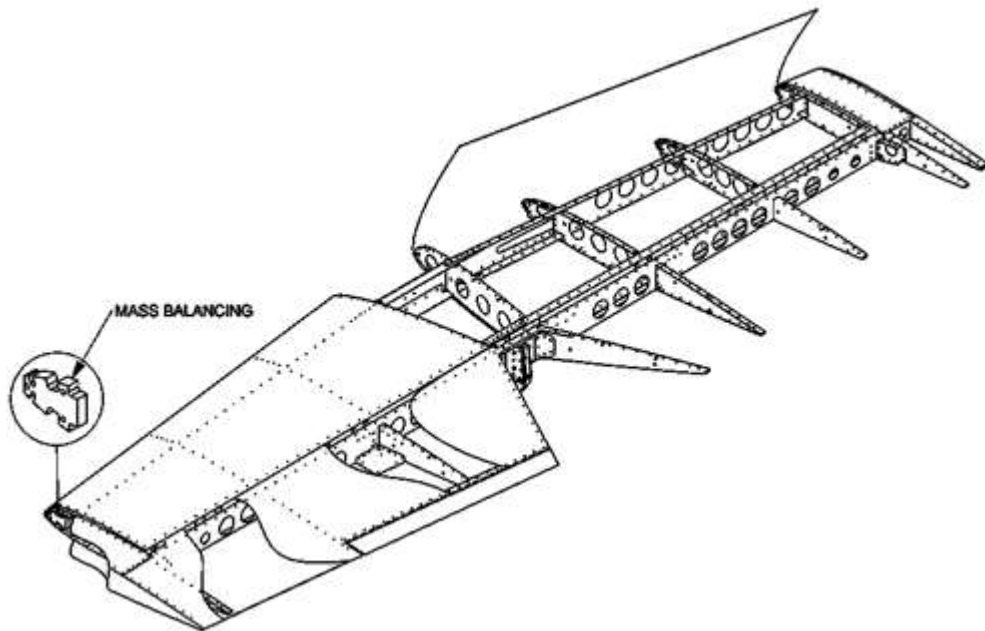

Figure 21: Horizontal tail and elevator.

Refer to Figure 21. The horizontal stabiliser consists of a conventional semi-monocoque all-metal light alloy structure with front and rear spars. The elevator has a similar structure, though with only a front spar. Bearings are again, as with all other control surface bearings,  $\frac{1}{4}$  inch sealed bearings. Elevator horns carry through to the leading edge of the horizontal tail and the elevator tips consist of shaped epoxy resin and glass fibre composite.

Elevator mass balancing is located in the two elevator horn leading edges. To inspect these parts it is necessary to remove the composite tips.

#### 4.2.1.1 ELEVATOR CONTROL SYSTEM

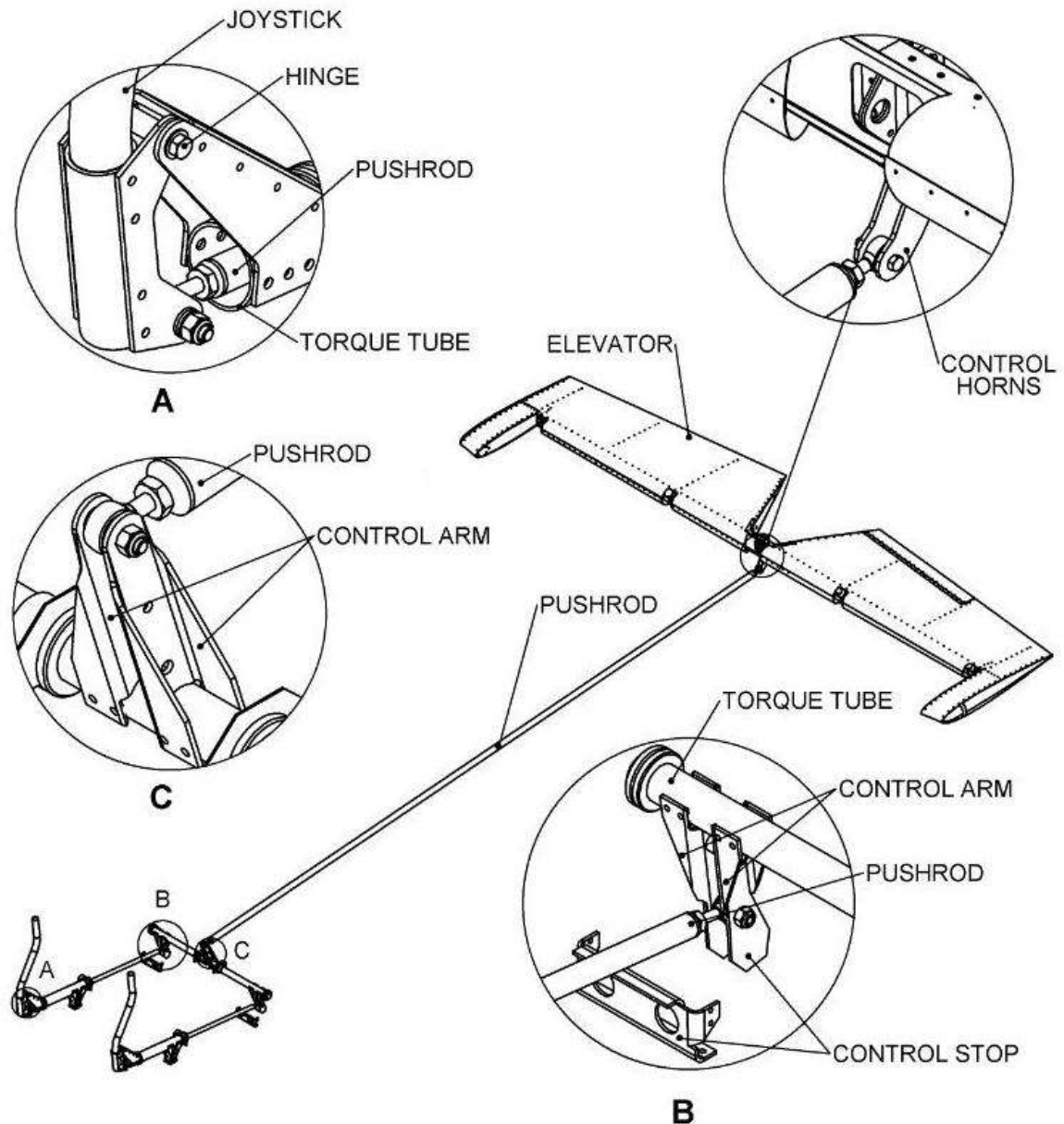

Figure 22: Elevator control system.

Refer to Figure 22. The elevator control system is push/pull type, controlled from the cabin via the control columns. Control is transmitted through a push/pull rod and bellcrank arrangement. All significant transmission elements such as bellcranks, pushrods, supports and hinges can be easily accessed and inspected.



**4.2.1.2 ELEVATOR REMOVAL / INSTALLATION**

TOOLS / EQUIPMENT REQUIRED		
ITEM	QUANTITY	NOTES
1	7/16 Spanner.	2
The above list is not necessarily a complete list of all required tools and equipment needed. A calibrated torque wrench (with adequate range) and the correct size (as implied by the above tool list) accessories (sockets etc.) are implied for torquing bolts / nuts, if applicable. Refer to paragraph 1.5 for torque values.		
CONSUMABLE MATERIAL REQUIRED		
ITEM	QUANTITY	NOTES
1	Orange paint.	As needed.
The above list is not necessarily a complete list of all material needed. Refer to the Sling 2 construction manual.		
AUTHORISED PERSONNEL		
Any person performing maintenance of any kind on the aircraft or any component thereof must do so in accordance with national legislation. This is the responsibility of the aircraft owner and any person who is to perform any maintenance on the aircraft.		

**CAUTION**  
**BE PREPARED WITH A HELPER OR SUPPORT STAND TO HANDLE THE WEIGHT AND / OR AWKWARDNESS OF THE OBJECT TO BE REMOVED.**

**CAUTION**  
**CONTROL SURFACE WILL ROTATE / FALL FREE WHEN THE CONTROL LINKAGE CONNECTED TO IT IS DISCONNECTED.**

## PROCEDURE (REMOVAL)

Retain any bolts, nuts (except lock-nuts) spacers, screws and washers (with the exception of lock-washers) for reassembly.

1. Remove the vertical stabiliser (refer to paragraph 4.2.2.3).
2. Support the elevator and disconnect the elevator pushrod from the elevator control horn (located inside the rear fuselage tail cone). The pushrod rod-end bearing is accessed through the two small round access holes on the left and right sides of the rear fuselage tail cone.
3. Support the elevator and loosen and remove the bolts from the elevator hinges.
4. Carefully and slowly pull the elevator free from the hinges and horizontal stabiliser, until the trim tab motor cable plug connection is exposed. Disconnect the plug.

## PROCEDURE (INSTALLATION)

1. Reverse the above procedure (removal), paying close attention to the following:
  - Inspect all bolts, nuts and screws for damage. Replace if necessary.
  - Do not reuse lock-nuts. Fit new.
  - Tighten the lock-nut on the bolt through the elevator pushrod rod-end bearing sufficiently. Observe the correct placement of washers (refer to Figure 23). Note that the bolt is installed with its head facing to the port side of the aircraft.

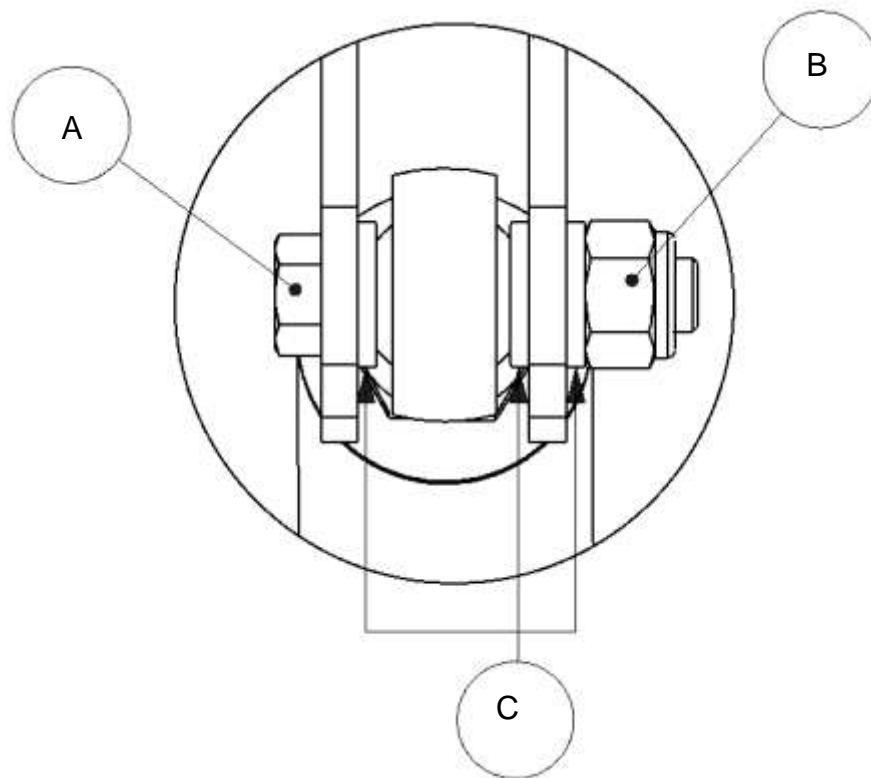

A	AN4-12A bolt
B	AN4 lock-nut (Nyloc)
C	AN4 washer (1.6 mm / 0.064")
Refer to paragraph 7 for hardware designations	

Figure 23: Elevator pushrod to elevator connection.

- Tighten the lock-nuts on the bolts through the elevator hinges sufficiently. Observe the correct placement of washers (refer to Figure 24). Note that the outer hinge bolts are installed with their heads facing outward, towards the elevator tips and the inner hinge bolts are installed with their heads facing inward, towards the fuselage/ tail cone. The bolt in the centre hinge is fitted with its head towards the larger clearance side of the elevator cut-out.

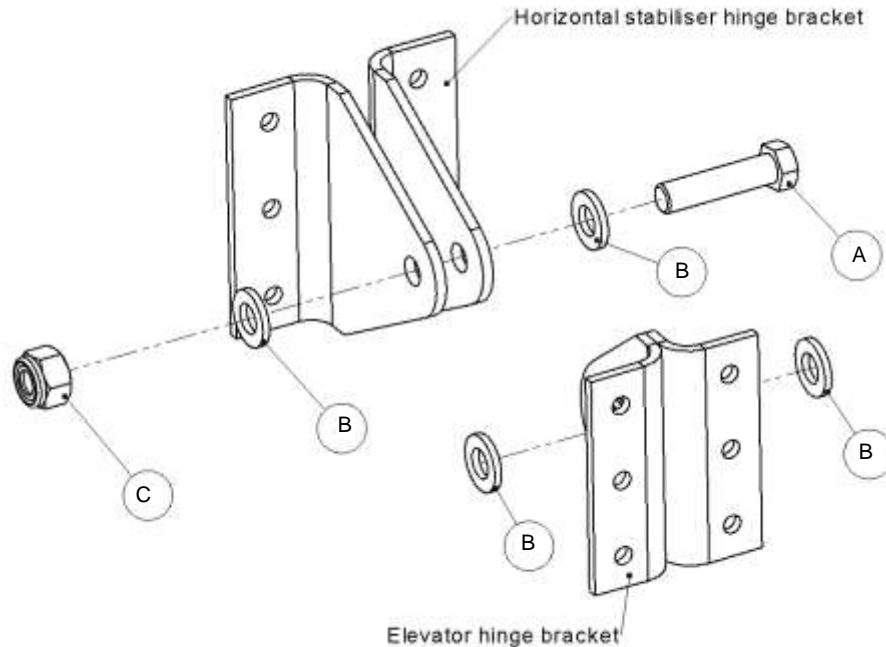

A	AN4-10A bolt
B	AN4 washer (1.6 mm / 0.064")
C	AN4 lock-nut (Nyloc)
Refer to paragraph 7 for hardware designations	

Figure 24: Horizontal stabilizer-to-elevator hinge connection.

2. Apply orange creep marks to the bolts / nuts.
3. Verify for elevator alignment and correct travel (refer to paragraph 1.13).

**4.2.1.3 HORIZONTAL STABILIZER REMOVAL / INSTALLATION**

TOOLS / EQUIPMENT REQUIRED		
ITEM	QUANTITY	NOTES
1	7/16 Spanner.	2
The above list is not necessarily a complete list of all required tools and equipment needed. A calibrated torque wrench (with adequate range) and the correct size (as implied by the above tool list) accessories (sockets etc.) are implied for torquing bolts / nuts, if applicable. Refer to paragraph 1.5 for torque values.		
CONSUMABLE MATERIAL REQUIRED		
ITEM	QUANTITY	NOTES
1	Orange paint.	As needed.
The above list is not necessarily a complete list of all material needed. Refer to the Sling 2 construction manual.		
AUTHORISED PERSONNEL		
Any person performing maintenance of any kind on the aircraft or any component thereof must do so in accordance with national legislation. This is the responsibility of the aircraft owner and any person who is to perform any maintenance on the aircraft.		

**CAUTION**

**BE PREPARED WITH A HELPER OR SUPPORT STAND TO HANDLE THE WEIGHT AND / OR AWKWARDNESS OF THE OBJECT TO BE REMOVED / INSTALLED.**

## PROCEDURE (REMOVAL)

Retain any bolts, nuts (except lock-nuts) spacers, screws and washers (with the exception of lock-washers) for reassembly.

1. Remove the vertical stabilizer. Refer to paragraph 4.2.2.3.
2. Disconnect the trim tab motor cable connection plug (1).



3. Support the horizontal stabilizer and unfasten and remove the bolts (2) retaining it to the fuselage.

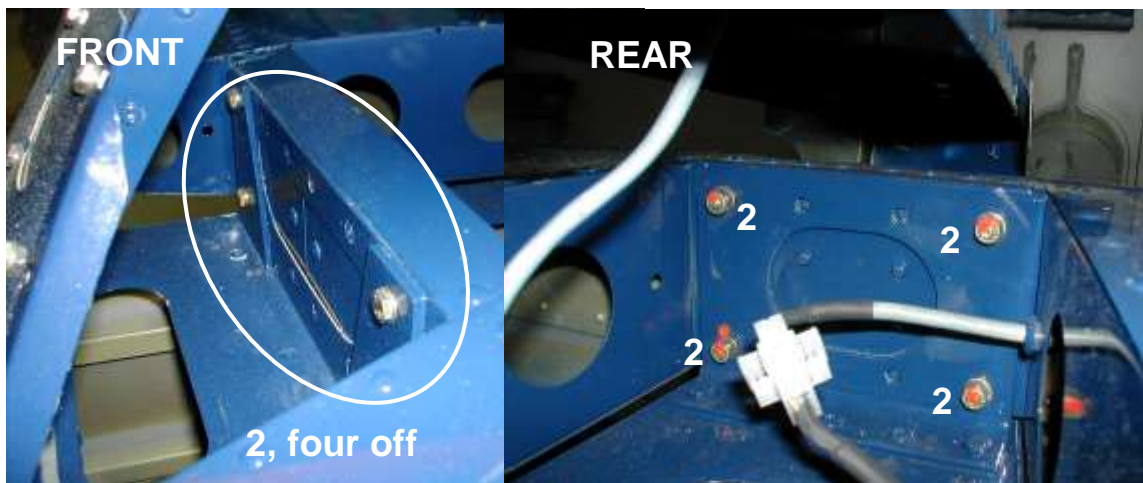

4. Carefully lift the horizontal stabilizer free from the fuselage.

**PROCEDURE (INSTALLATION)**

1. Reverse the above procedure (removal), paying close attention to the following:

- Inspect all bolts, nuts and screws for damage. Replace if necessary.
- Do not reuse lock-nuts. Fit new.
- Tighten the lock-nuts sufficiently. Observe the correct placement of washers (refer to Figure 25).

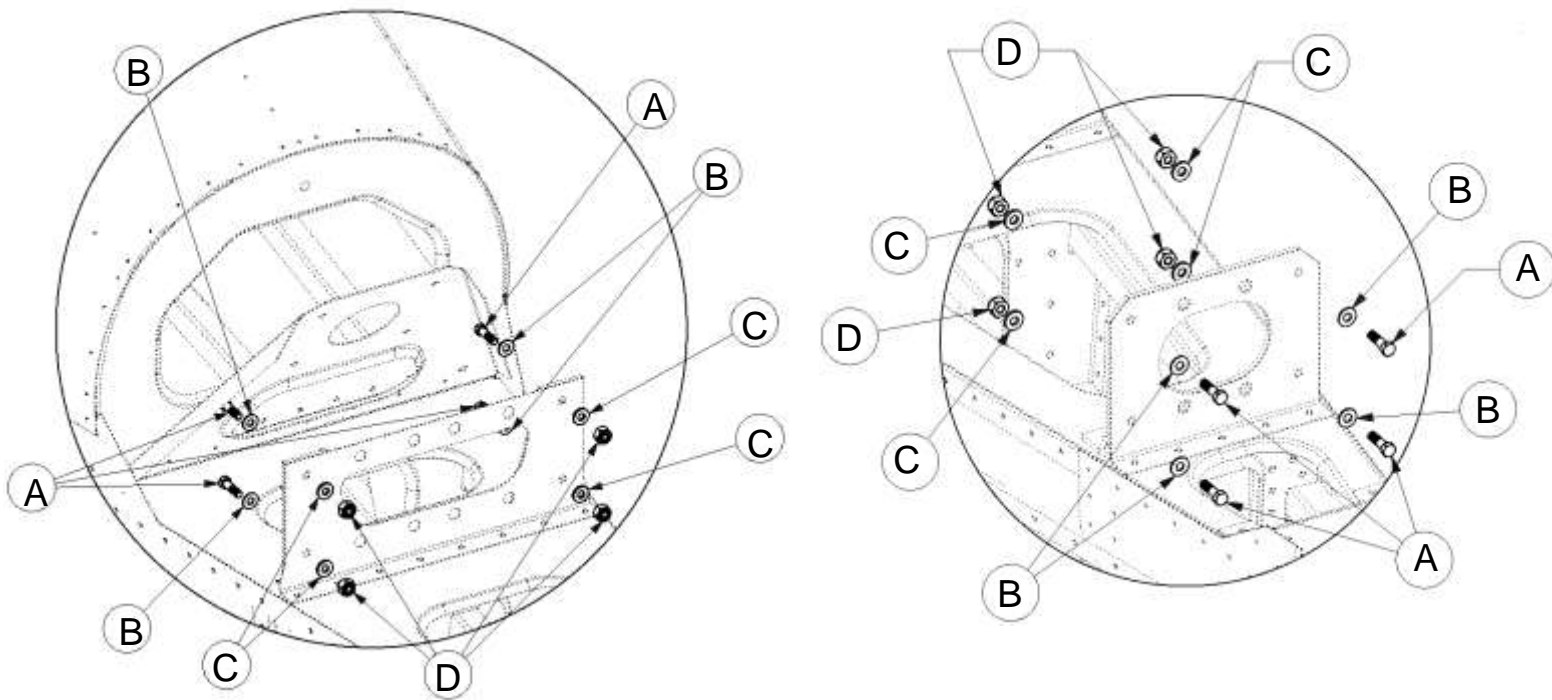

A	AN3-5A bolt
B	AN3 washer (0.8 mm / 0.032")
C	AN3 washer (1.6 mm / 0.064")
D	AN3 lock-nut (Nyloc)
Refer to paragraph 7 for hardware designations	

Figure 25: Horizontal stabilizer to fuselage attachment.

#### 4.2.1.4 ELEVATOR TRIM TAB MOTOR REMOVAL / INSTALLATION

TOOLS / EQUIPMENT REQUIRED			
ITEM		QUANTITY	NOTES
1	2 mm Allen key / hex drive.	2	
2	Electric solder iron.	1	
The above list is not necessarily a complete list of all required tools and equipment needed. A calibrated torque wrench (with adequate range) and the correct size (as implied by the above tool list) accessories (sockets etc.) are implied for torquing bolts / nuts, if applicable. Refer to paragraph 1.5 for torque values.			
CONSUMABLE MATERIAL REQUIRED			
ITEM		QUANTITY	NOTES
1	2.4 mm Heat shrink.	As needed.	
2	6.4 mm Heat shrink.	As needed.	
3	Solder.	As needed.	
4	Loctite 222.	As needed.	Inspection panel and trim tab motor screws.
The above list is not necessarily a complete list of all material needed. Refer to the Sling 2 construction manual.			
AUTHORISED PERSONNEL			
Any person performing maintenance of any kind on the aircraft or any component thereof must do so in accordance with national legislation. This is the responsibility of the aircraft owner and any person who is to perform any maintenance on the aircraft.			



## PROCEDURE (REMOVAL)

1. Remove the elevator trim motor inspection cover (1) (under the port elevator) by unscrewing the button head screws (2).

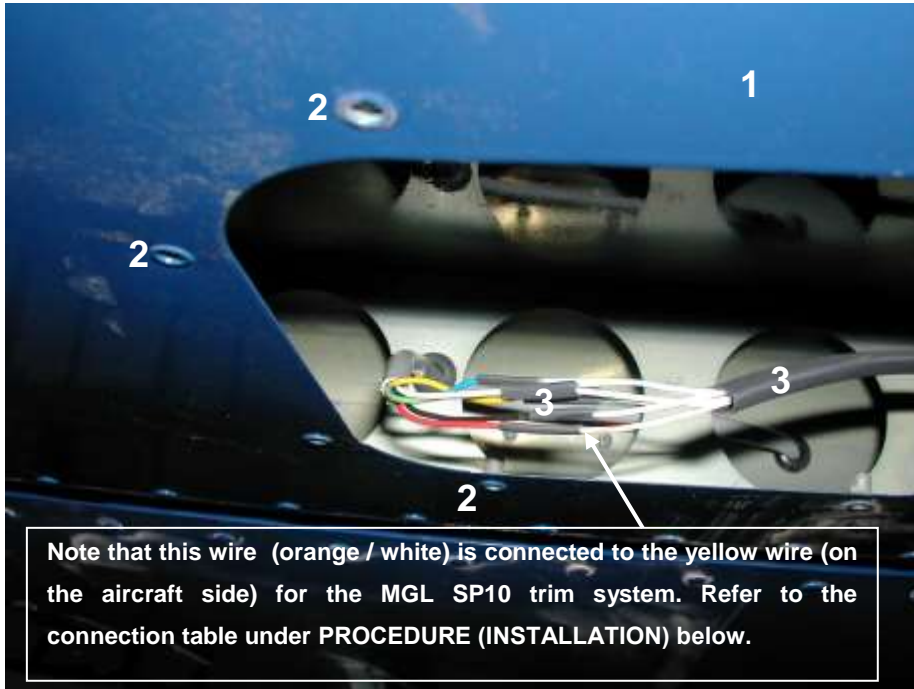

2. Remove the heat shrink (3) from the trim motor wiring (4) and desolder the wires. Mark the white wire (motor side) connected to the black wire (aircraft side), to ease later reconnection.
3. Remove the split pin from the trim tab pushrod connected to the motor, push out the pin and washer and disconnect the pushrod from the servo.
4. Unscrew the four button head screws (5) retaining the trim tab motor and remove the motor from inside the elevator.

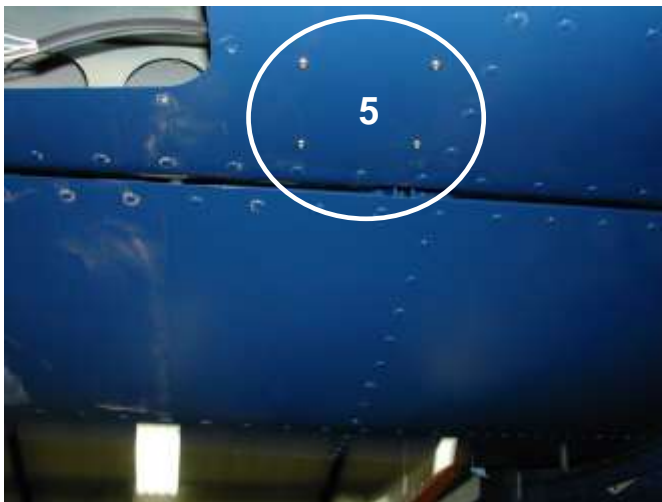

## PROCEDURE (INSTALLATION)

1. Reverse the above procedure (removal), paying close attention to the following:

- Inspect all bolts and / or screws for damage. Replace if necessary.
- Apply thread locking sealant to the trim tab motor retaining screws before fitment.
- Reconnect the elevator trim tab motor wires as follows:

WIRE COLOUR (AIRCRAFT SIDE)		WIRE COLOUR (TRIM MOTOR SIDE)	NOTES	
Blue	to	Blue / white		
Green	to	Green / white		
Red	to	Orange / white		
Yellow	Not connected		Ensure that the free end of this wire is properly insulated.	
Black	to	White	Reconnect to the white wire marked during elevator removal.	If the white wires are not marked, arbitrarily connect the black and white wires on the aircraft side to the white wires on the trim motor side. Activate the trim motor and observe the direction of travel. If incorrect, reverse the two wire connections.
White	to	White	Reconnect to the white wire not marked during elevator removal.	

- Fit the heat shrink over the applicable wires before soldering the connections. Push the heat shrink far enough to the side to prevent the heat shrink from prematurely shrinking due to the heat from soldering the wire connections. Allow the soldered wire connections to cool, then move the heat shrink into place and shrink with a suitable heat source. Do not burn the heat shrink.

2. Verify for trim tab alignment and correct travel (refer to paragraph 1.13).

3. Ensure no loose articles or tools are left in the elevator before refitting the inspection panel.

4. Apply thread locking sealant to the screws and refit the inspection panel.

**4.2.1.5 ELEVATOR ADJUSTMENT**

TOOLS / EQUIPMENT REQUIRED		
ITEM	QUANTITY	NOTES
1	7/16 Spanner.	1
2	Inclinometer.	1
The above list is not necessarily a complete list of all required tools and equipment needed. A calibrated torque wrench (with adequate range) and the correct size (as implied by the above tool list) accessories (sockets etc.) are implied for torquing bolts / nuts, if applicable. Refer to paragraph 1.5 for torque values.		
CONSUMABLE MATERIAL REQUIRED		
ITEM	QUANTITY	NOTES
1	Orange paint.	As needed.
The above list is not necessarily a complete list of all material needed. Refer to the Sling 2 construction manual.		
AUTHORISED PERSONNEL		
Any person performing maintenance of any kind on the aircraft or any component thereof must do so in accordance with national legislation. This is the responsibility of the aircraft owner and any person who is to perform any maintenance on the aircraft.		

**CAUTION**

**BE PREPARED WITH A HELPER OR SUPPORT STAND TO HANDLE THE WEIGHT AND / OR AWKWARDNESS OF THE OBJECT (SEATS) TO BE REMOVED / INSTALLED.**

## PROCEDURE

Retain any bolts, nuts (except lock-nuts) spacers, screws and washers (with the exception of lock-washers) for reassembly.

1. Remove the seats (refer to paragraph 4.3.2.1).
2. Move the control sticks (1) forward until the stops engage. Undo the lock-nuts and adjust the stick pushrods (2) until the sticks are approximately 25 mm (1") away from the front panel.

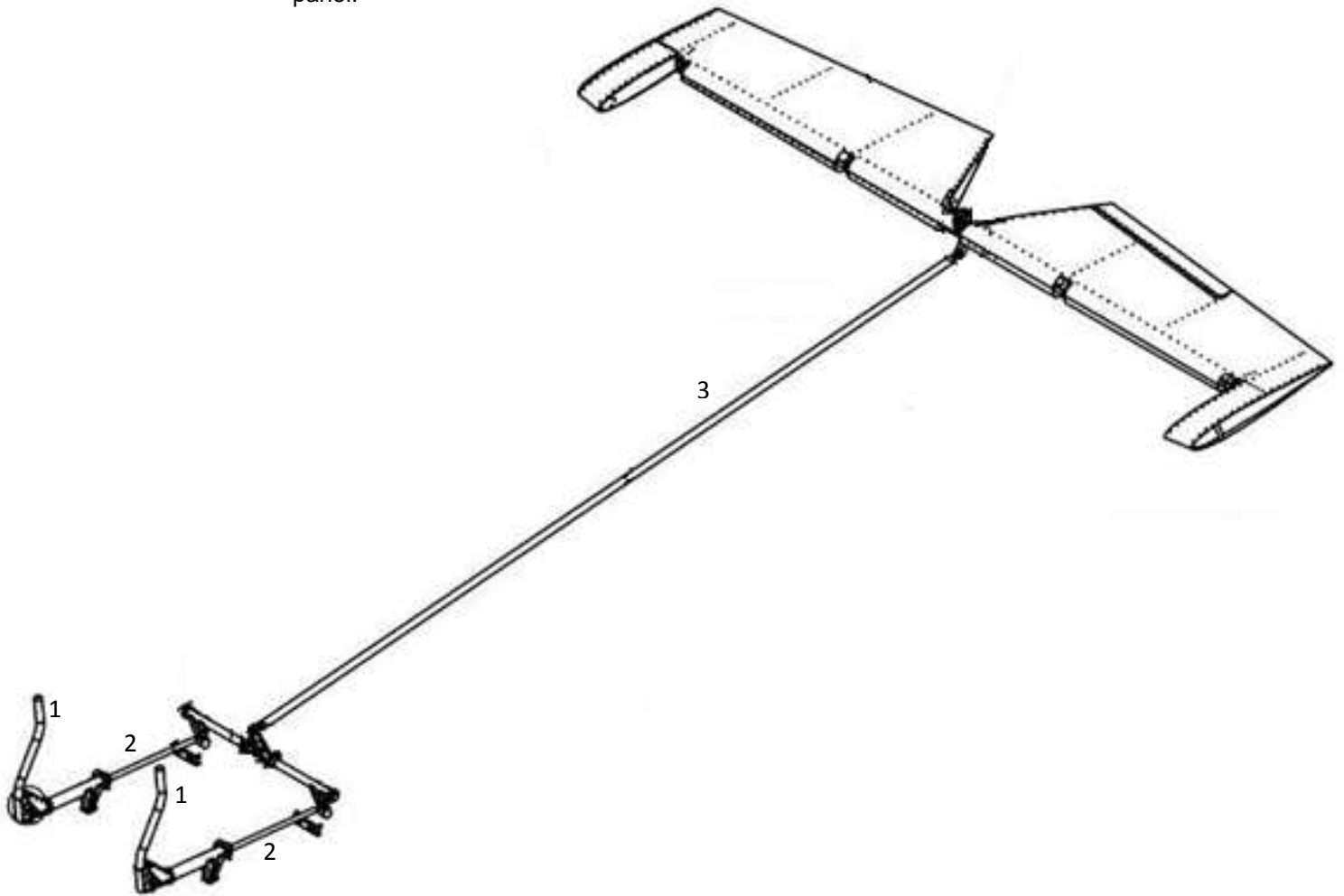

Figure 26: Elevator adjustment.

3. Hold the elevator in line with the horizontal stabilizer. Put an inclinometer on it and zero the inclinometer.
4. Undo the lock-nuts and adjust the pushrod (3) until the elevator is 20° down (from the zero level in line with the horizontal stabilizer) with the sticks fully forward (with the stops engaged) and 28° up with the sticks fully backward (i.e. with the stops engaged).
5. Tighten the lock-nuts on the pushrods without turning the pushrods.
6. Paint orange creep marks on the lock-nuts.
7. Ensure that no tools or foreign material is left behind before refitting the seats.
8. Verify correct travel and full and free movement before flight.

**4.2.1.6 ELEVATOR TRIM TAB ADJUSTMENT**

TOOLS / EQUIPMENT REQUIRED		
ITEM	QUANTITY	NOTES
1	¼ inch Spanner.	1
The above list is not necessarily a complete list of all required tools and equipment needed. A calibrated torque wrench (with adequate range) and the correct size (as implied by the above tool list) accessories (sockets etc.) are implied for torquing bolts / nuts, if applicable. Refer to paragraph 1.5 for torque values.		
CONSUMABLE MATERIAL REQUIRED		
ITEM	QUANTITY	NOTES
1	Split pin.	1
The above list is not necessarily a complete list of all material needed. Refer to the Sling 2 construction manual.		
AUTHORISED PERSONNEL		
Any person performing maintenance of any kind on the aircraft or any component thereof must do so in accordance with national legislation. This is the responsibility of the aircraft owner and any person who is to perform any maintenance on the aircraft.		

## PROCEDURE

1. Turn the Master switch ON.
2. Trim the trim tab to the maximum down deflection (i.e. the aircraft will pitch up in flight).
3. Turn the Master switch OFF.
4. Loosen the lock nut (1), i.e. screw it backward on the threaded rod (2), away from the eye-bolt (3).
5. Remove the split pin, pin and washer (4) and disconnect the eye-bolt from the trim tab horn (5).

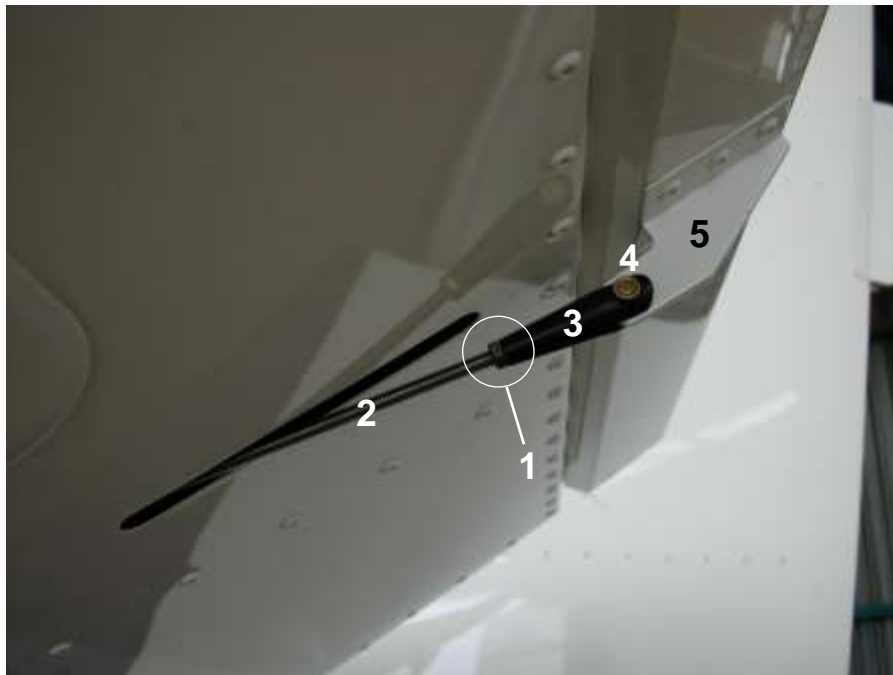

6. Adjust the eye-bolt on the threaded rod, temporarily reattach to the trim tab horn and measure the trim tab deflection downwards relative to the elevator upper surface (use a protractor or measure the downward displacement of the trim tab trailing edge). Repeat step 4 until the deflection measures equal to 25°.
7. Do not reuse split pin. Fit new. Note that the pin is inserted with the split pin and washer facing towards the aircraft fuselage.
8. Tighten the lock nut against the eye-bolt.
9. Before flight, verify correct operation and travel (refer to paragraph 1.13) of the elevator trim tab.

**4.2.1.7 ELEVATOR AUTOPILOT SERVO REMOVAL / INSTALLATION**

TOOLS / EQUIPMENT REQUIRED		
ITEM	QUANTITY	NOTES
1	3/8 Spanner.	2
2	4 mm Allen key / hex drive.	1
3	Flat screwdriver.	1
The above list is not necessarily a complete list of all required tools and equipment needed. A calibrated torque wrench (with adequate range) and the correct size (as implied by the above tool list) accessories (sockets etc.) are implied for torquing bolts / nuts, if applicable. Refer to paragraph 1.5 for torque values.		
CONSUMABLE MATERIAL REQUIRED		
ITEM	QUANTITY	NOTES
1	Tie wraps.	As needed.
2	Orange paint.	As needed.
3	Loctite 243.	As needed. Servo mounting screws.
The above list is not necessarily a complete list of all material needed. Refer to the Sling 2 construction manual.		
AUTHORISED PERSONNEL		
Any person performing maintenance of any kind on the aircraft or any component thereof must do so in accordance with national legislation. This is the responsibility of the aircraft owner and any person who is to perform any maintenance on the aircraft.		

**WARNING**

**ENSURE MASTER AND ELECTRICAL EQUIPMENT SWITCHES ARE OFF.**

**IT MAY BE EXPEDIENT TO DISCONNECT THE BATTERY GROUND TERMINAL WHILE WORKING ON ELECTRICAL EQUIPMENT.**

**CAUTION**

**BE PREPARED WITH A HELPER OR SUPPORT STAND TO HANDLE THE WEIGHT AND / OR AWKWARDNESS OF THE OBJECT (SEAT) TO BE REMOVED.**



## PROCEDURE (REMOVAL)

Retain any bolts, nuts (except lock-nuts) spacers, screws and washers (with the exception of lock-washers) for reassembly.

1. Remove the port seat (refer to paragraph 4.3.2) to gain access to the servo.
2. Undo the bolt (1) connecting the control arm of the servo (2) to the pushrod (3).

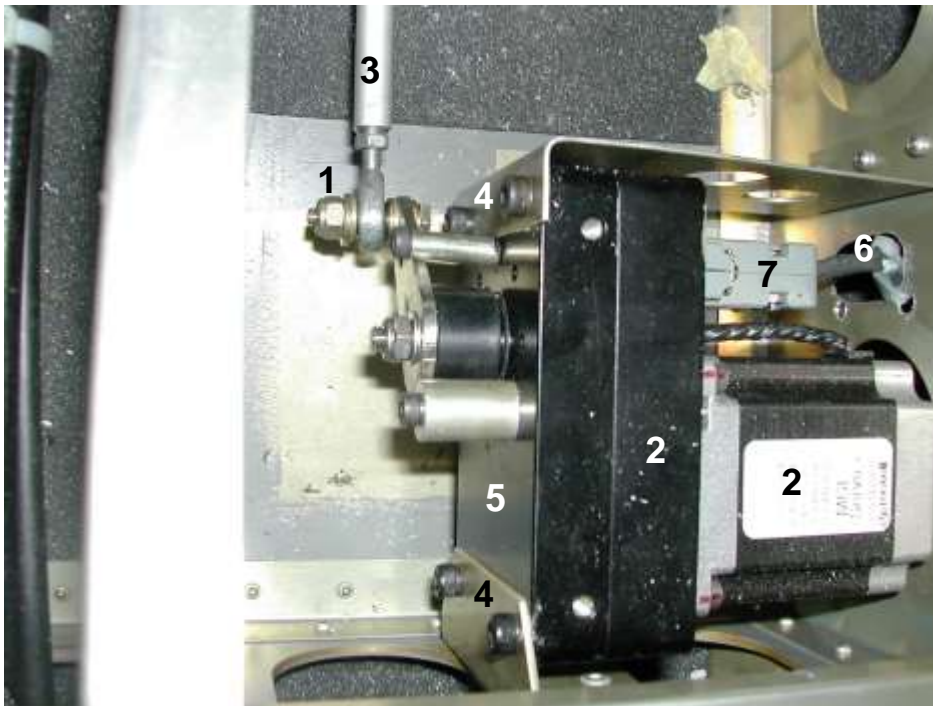

3. Undo the screws (4) retaining the servo to the bracket (5). Carefully pull the motor from the bracket. It may be necessary to cut the tie wrap(s) securing the cable (6) to the aircraft frame to allow adequate play in the cable.
4. Undo the screws securing the connector (7) to the servo motor and disconnect from the servo.

**PROCEDURE (INSTALLATION)**

1. Reverse the above procedure (removal), paying close attention to the following:
  - Inspect all bolts, nuts and screws for damage. Replace if necessary.
  - Do not reuse lock-nuts. Fit new.
  - If applicable secure the servo cable to the aircraft frame with tie wraps, in the manner it was before removal, using spacers as applicable.
  - Apply thread locking sealant to the servo mounting screws before fitment. Do not over tighten.
  - Observe the correct placement of washers (refer to Figure 27).

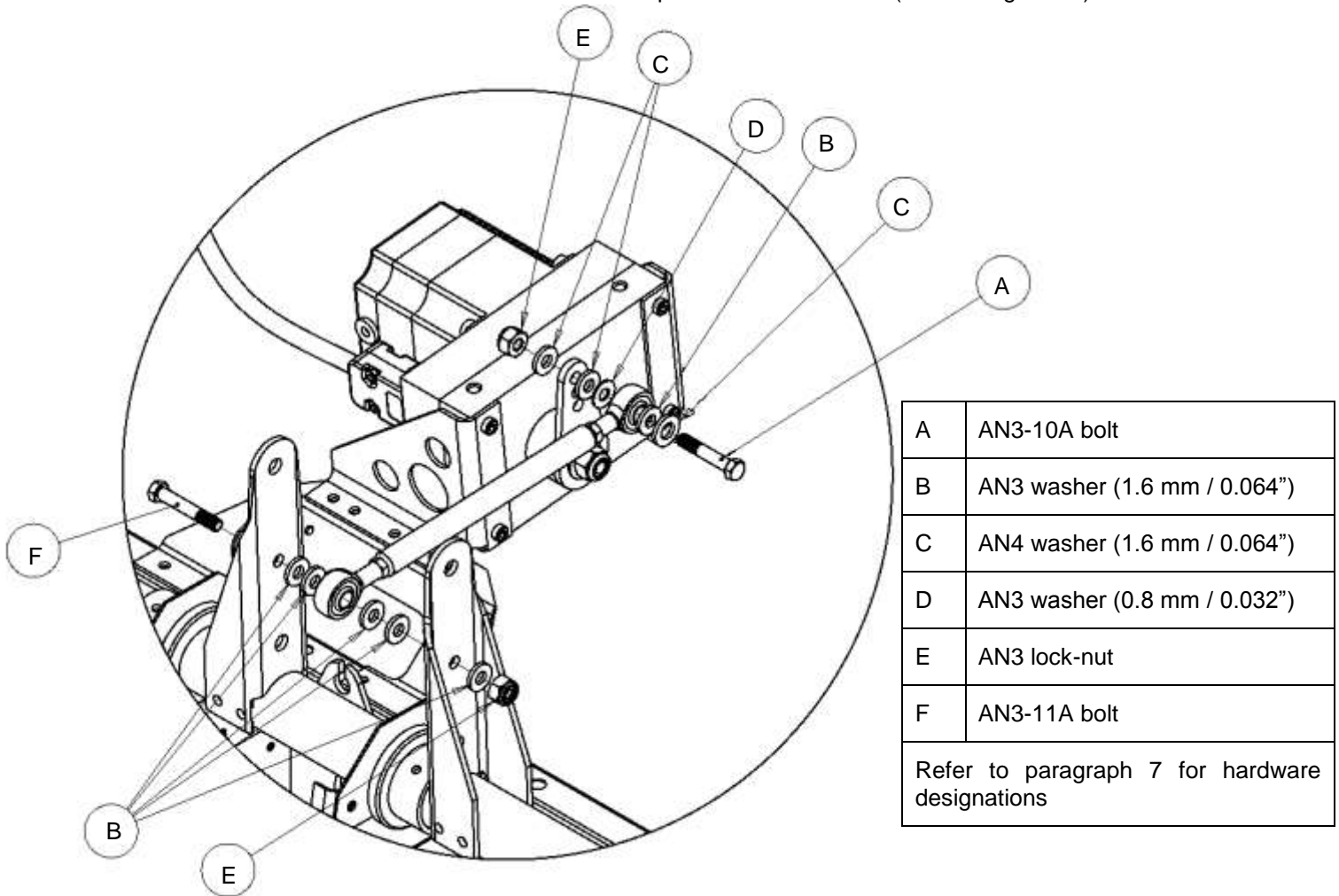

Figure 27: Autopilot elevator servo installation.

- Paint orange creep marks on the bolts / lock-nuts.

2. Inspect for security of attachment. Ensure servo signal cable will not chafe against the aircraft frame.
3. Ensure the applicable aircraft control(s) is (are) free and does not bind with the servo installed.
4. Follow any applicable procedures in the latest revision of the MGL Avionics EFIS integrated autopilot user and installation manual to complete installation of the servo.
5. Before flight, test the servo for correct operation (refer to the latest revision of the MGL Avionics EFIS integrated autopilot user and installation manual).

#### 4.2.2 VERTICAL TAIL AND RUDDER

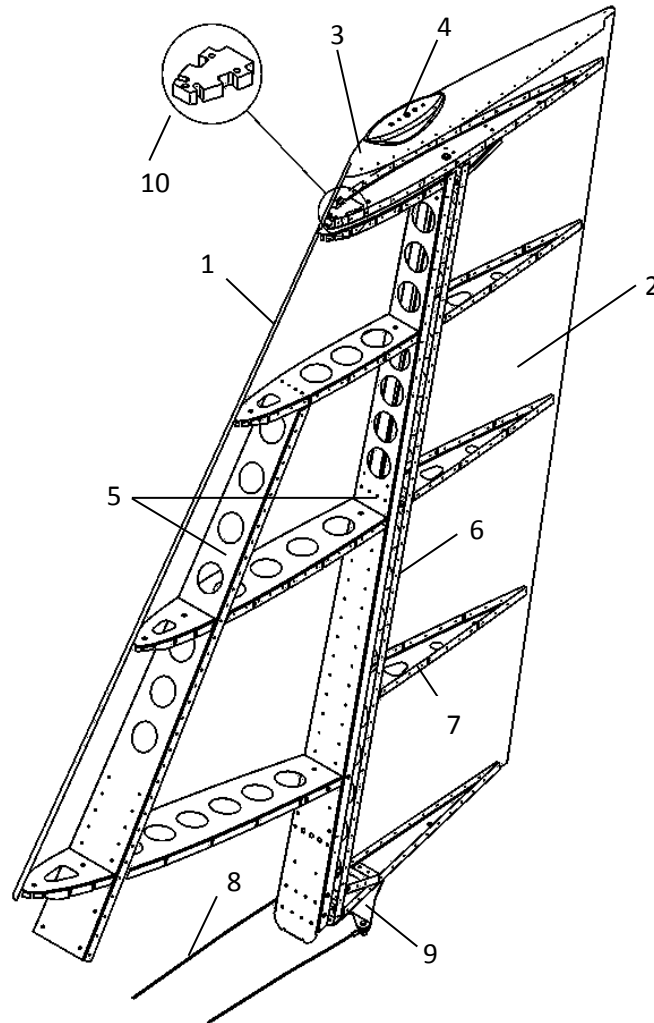

Figure 28: Vertical tail and rudder.

Refer to Figure 28. The vertical (1) stabiliser and rudder (2) consist of all-metal light alloy structures. The rudder horn (3) extends to the vertical stabiliser leading edge and has a composite tip on which navigation lights (4) and an aerial may be fitted. The vertical stabiliser consists of twin spars (5) with wrap-around stressed skin panelling. An attachment plate secures the vertical stabiliser's front spar to a bracket attached to the penultimate tail cone rib. The rudder consists of a spar (6) with formed sheet metal ribs (7) and sheet-metal skin. The rudder rotates / deflects around three hinges. Rudder control is effected by steel cables (8) attached to a control horn (9) on the bottom edge of the rudder and running (with a cross-over) to two control horns attached to the rudder pedal axles. Rudder mass balancing (10) is placed under the leading edge of the rudder horn, on the top rudder rib.

#### 4.2.2.1 RUDDER CONTROL SYSTEM

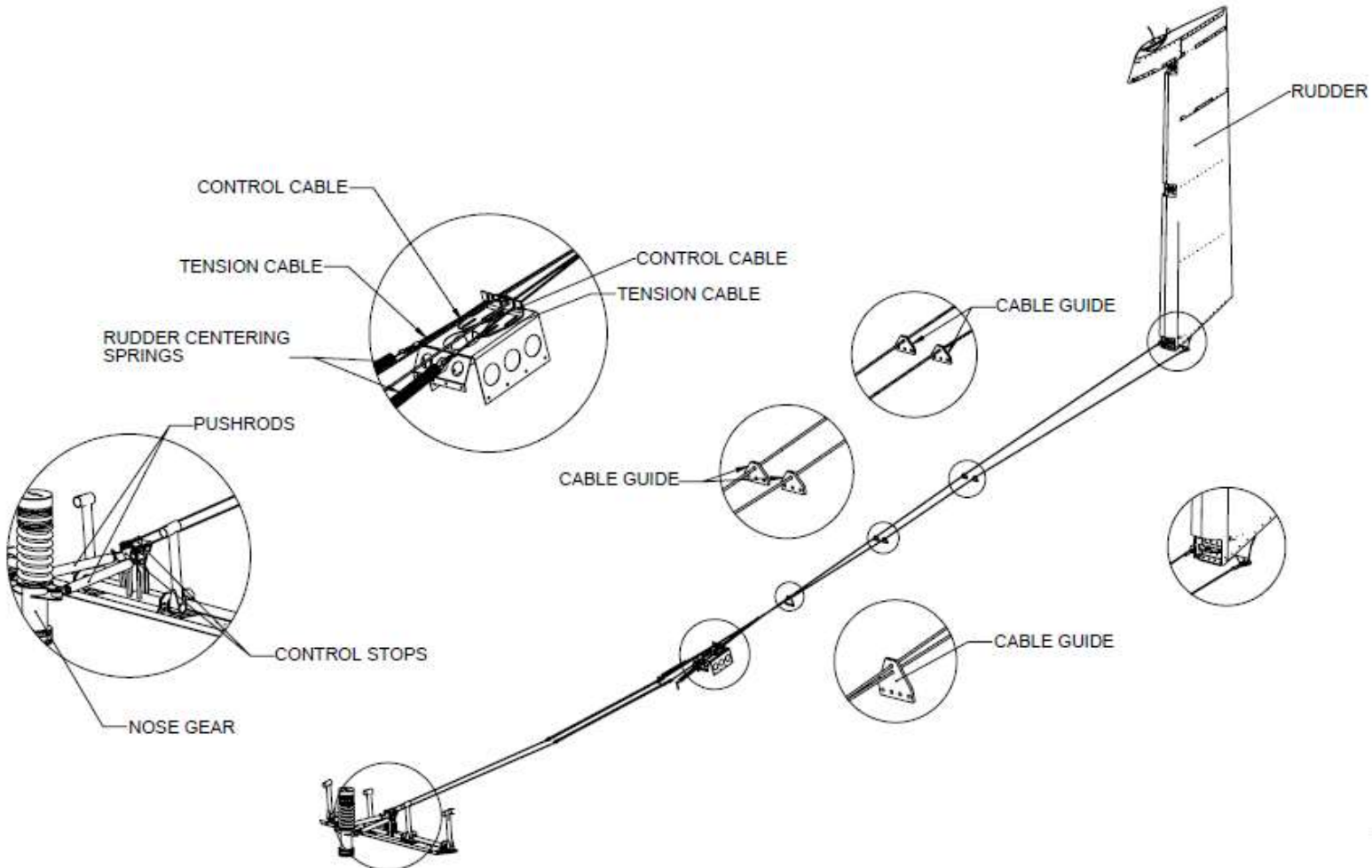

Figure 29: Rudder control system.

Refer to Figure 29. The control system layout is two steel cables attached to the rudder control horn at the bottom of the rudder. The cables are supported and aligned by cable guides. The cables terminate on two rudder pedal control horns. Control stops limit movement of the pedal to cable attachment horns. These horns are in turn attached to two adjustable pushrods which are attached to a control horn on the nose wheel strut (detail B)

The rudder pedals can be adjusted backwards and forwards on tubular slides (to set positions) and locked in position with bolts and lock-nuts.

In the rear fuselage the rudder cables are attached to a spring load device (detail A) which provides a centring force on the rudder.

**4.2.2.2 RUDDER REMOVAL / INSTALLATION**

TOOLS / EQUIPMENT REQUIRED		
ITEM	QUANTITY	NOTES
1	7/16 Spanner.	2
2	3/8 Spanner.	2
The above list is not necessarily a complete list of all required tools and equipment needed. A calibrated torque wrench (with adequate range) and the correct size (as implied by the above tool list) accessories (sockets etc.) are implied for torquing bolts / nuts, if applicable. Refer to paragraph 1.5 for torque values.		
CONSUMABLE MATERIAL REQUIRED		
ITEM	QUANTITY	NOTES
1	Orange paint.	As needed.
The above list is not necessarily a complete list of all material needed. Refer to the Sling 2 construction manual.		
AUTHORISED PERSONNEL		
Any person performing maintenance of any kind on the aircraft or any component thereof must do so in accordance with national legislation. This is the responsibility of the aircraft owner and any person who is to perform any maintenance on the aircraft.		

**CAUTION**  
**BE PREPARED WITH A HELPER OR SUPPORT STAND TO HANDLE THE WEIGHT**  
**AND / OR AWKWARDNESS OF THE OBJECT TO BE REMOVED.**

## PROCEDURE (REMOVAL)

Retain bolts, spacers, screws and washers (with the exception of lock-washers), as applicable, for reassembly.

1. Disconnect the control cables (1) from the rudder control horn (2).

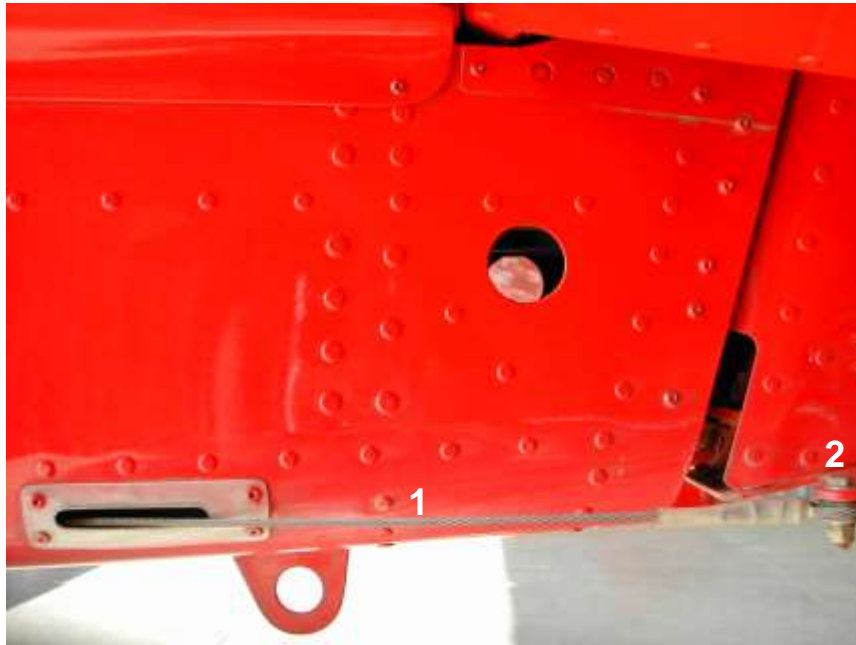

2. Push and retain the rudder to one side to gain easier access to the rudder hinges.
3. Support the rudder and loosen and remove the hinge bolts.
4. Carefully and slowly pull the rudder away from the vertical tail and hinges, until the strobe light connection plug is exposed. Disconnect the plug.
5. Move the rudder away from the rudder. Take care to protect the horn as it clears the top of the horizontal stabilizer.

**PROCEDURE (INSTALLATION)**

1. Reverse the above procedure, paying close attention to the following:

- Inspect all bolts, nuts and screws for damage. Replace if necessary.
- Do not reuse lock-nuts, lock-washers or split pins, as applicable. Fit new.
- Tighten the lock-nuts on the bolts through the rudder hinges sufficiently, observe the correct placement of washers (refer to
- Figure 30) and note that the bolts are installed with their heads facing upwards.

**Vertical stabiliser hinge bracket**

A	AN4-10A bolt
B	AN4 washer (1.6 mm / 0.064")
C	AN4 lock-nut (Nyloc)
Refer to paragraph 7 for hardware designations	

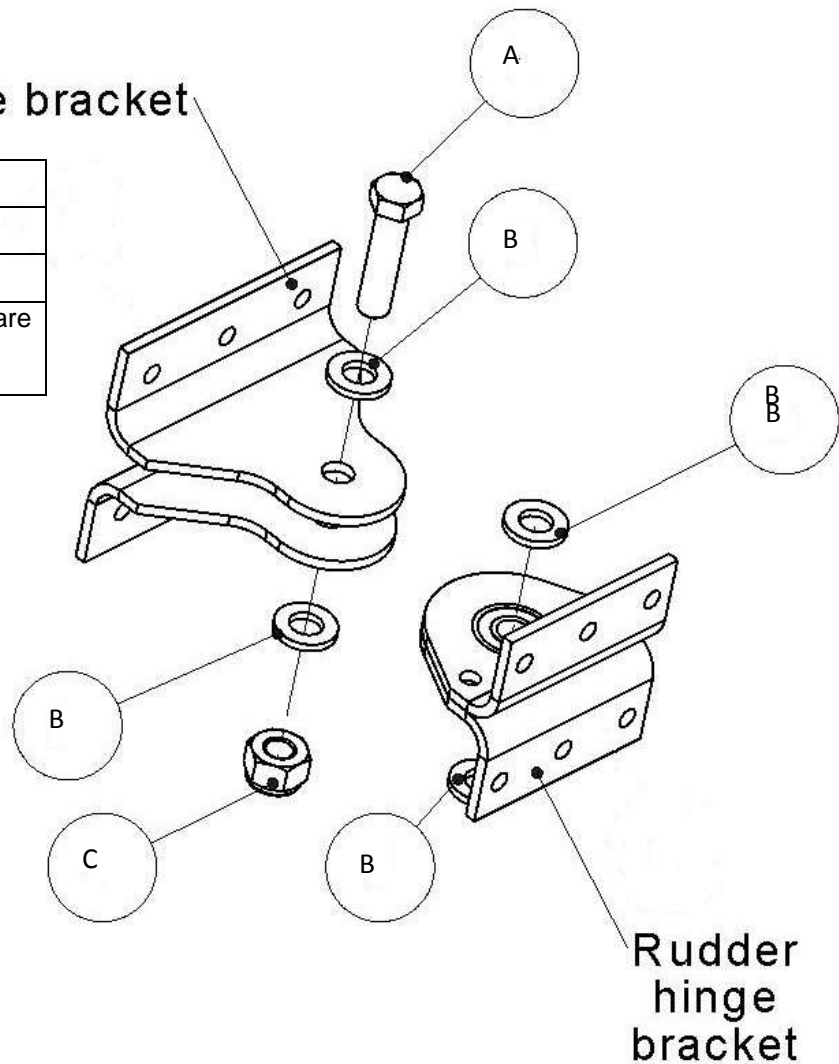

Figure 30: Rudder to vertical stabilizer hinge connection.



- Tighten the lock-nuts on the bolts attaching the rudder cables sufficiently, observe the correct placement of washers (refer to Figure 31) and note that the bolts are installed with their heads facing upwards.

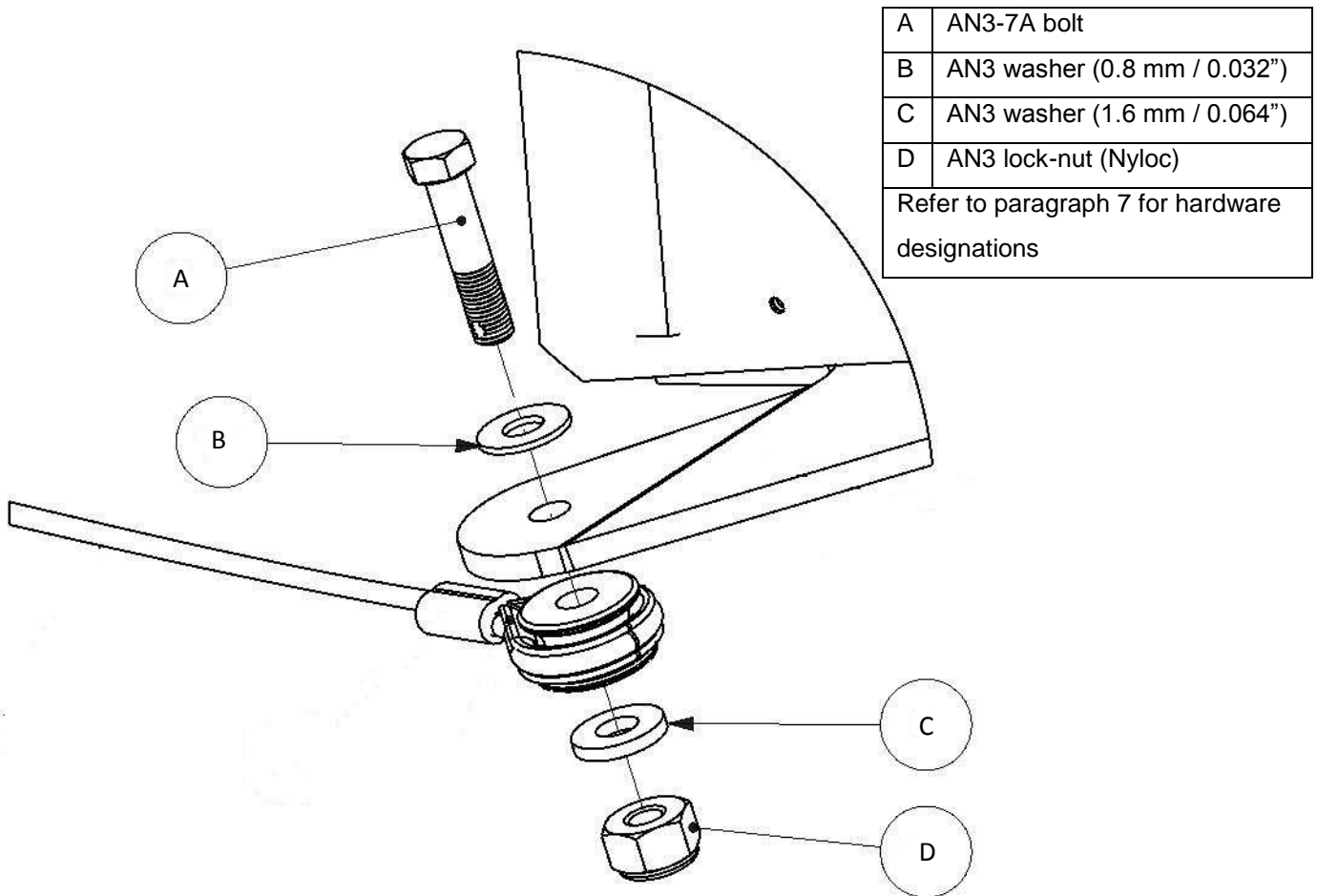

Figure 31: Rudder cable connection.

2. Apply orange creep marks to the bolts / nuts.
3. Verify for alignment and correct rudder travel (refer to paragraph 1.13).

**4.2.2.3 VERTICAL STABILIZER REMOVAL**

TOOLS / EQUIPMENT REQUIRED		
ITEM	QUANTITY	NOTES
1	3/8 Spanner.	2
2	2 mm Allen key / hex drive.	1
The above list is not necessarily a complete list of all required tools and equipment needed. A calibrated torque wrench (with adequate range) and the correct size (as implied by the above tool list) accessories (sockets etc.) are implied for torquing bolts / nuts, if applicable. Refer to paragraph 1.5 for torque values.		
CONSUMABLE MATERIAL REQUIRED		
ITEM	QUANTITY	NOTES
1	Orange paint.	As needed.
2	Loctite 222.	As needed. Fairing screws.
The above list is not necessarily a complete list of all material needed. Refer to the Sling 2 construction manual.		
AUTHORISED PERSONNEL		
Any person performing maintenance of any kind on the aircraft or any component thereof must do so in accordance with national legislation. This is the responsibility of the aircraft owner and any person who is to perform any maintenance on the aircraft.		

**CAUTION**

**BE PREPARED WITH A HELPER OR SUPPORT STAND TO HANDLE THE WEIGHT AND / OR AWKWARDNESS OF THE OBJECT TO BE REMOVED / INSTALLED.**

## PROCEDURE (REMOVAL)

Retain bolts, spacers, screws and washers (with the exception of lock-washers), as applicable, for reassembly.

1. Remove the rudder (refer to paragraph 4.2.2.2).
2. Remove the empennage-to-fuselage fairing (1), by unscrewing the button head screws retaining it.
3. Remove the side panel (2) on each side of the fuselage, by unscrewing the button head screws (3) retaining it.

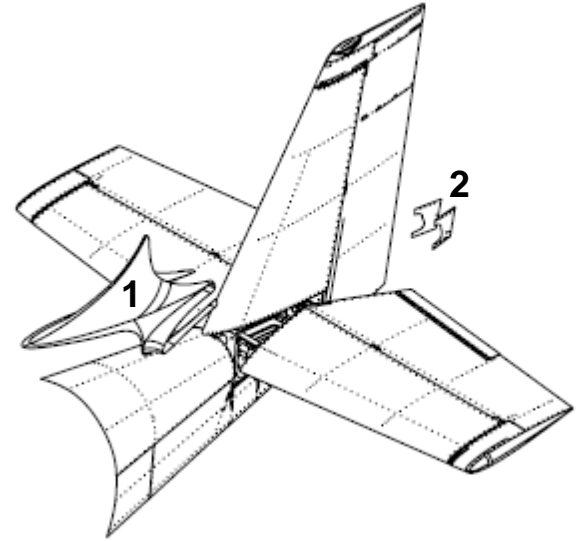
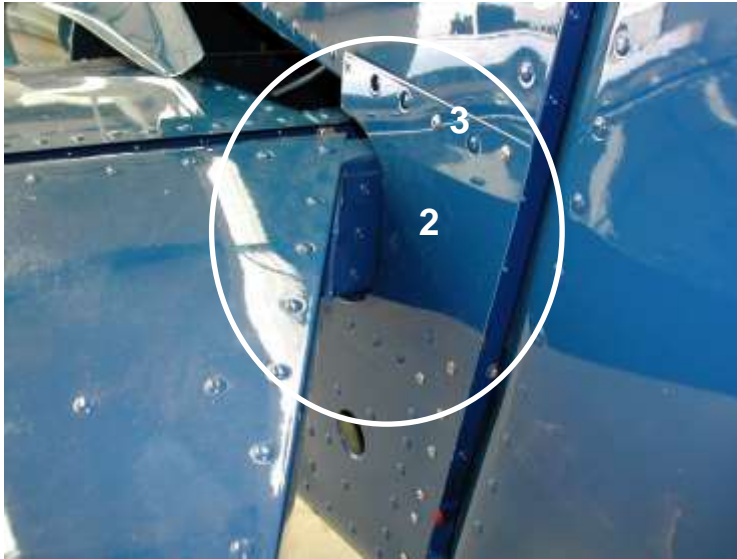

4. Disconnect the strobe light cable connector (4).

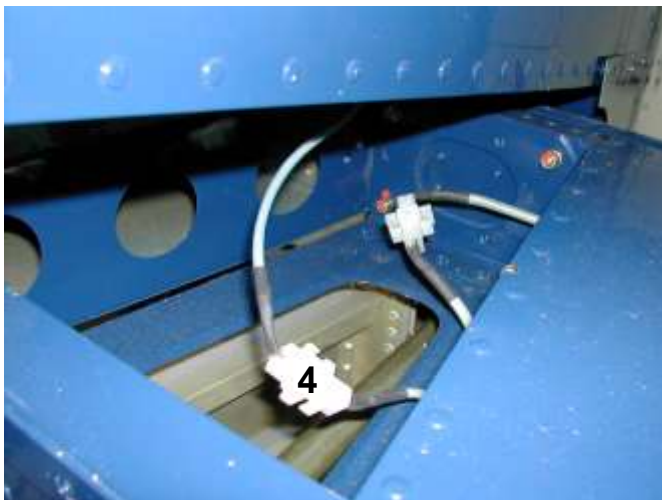

5. Support the vertical tail and unfasten the bolts (5) retaining the vertical tail to the fuselage. Note that the six bottom bolts in the rear screw into anchor nuts attached to the fuselage.

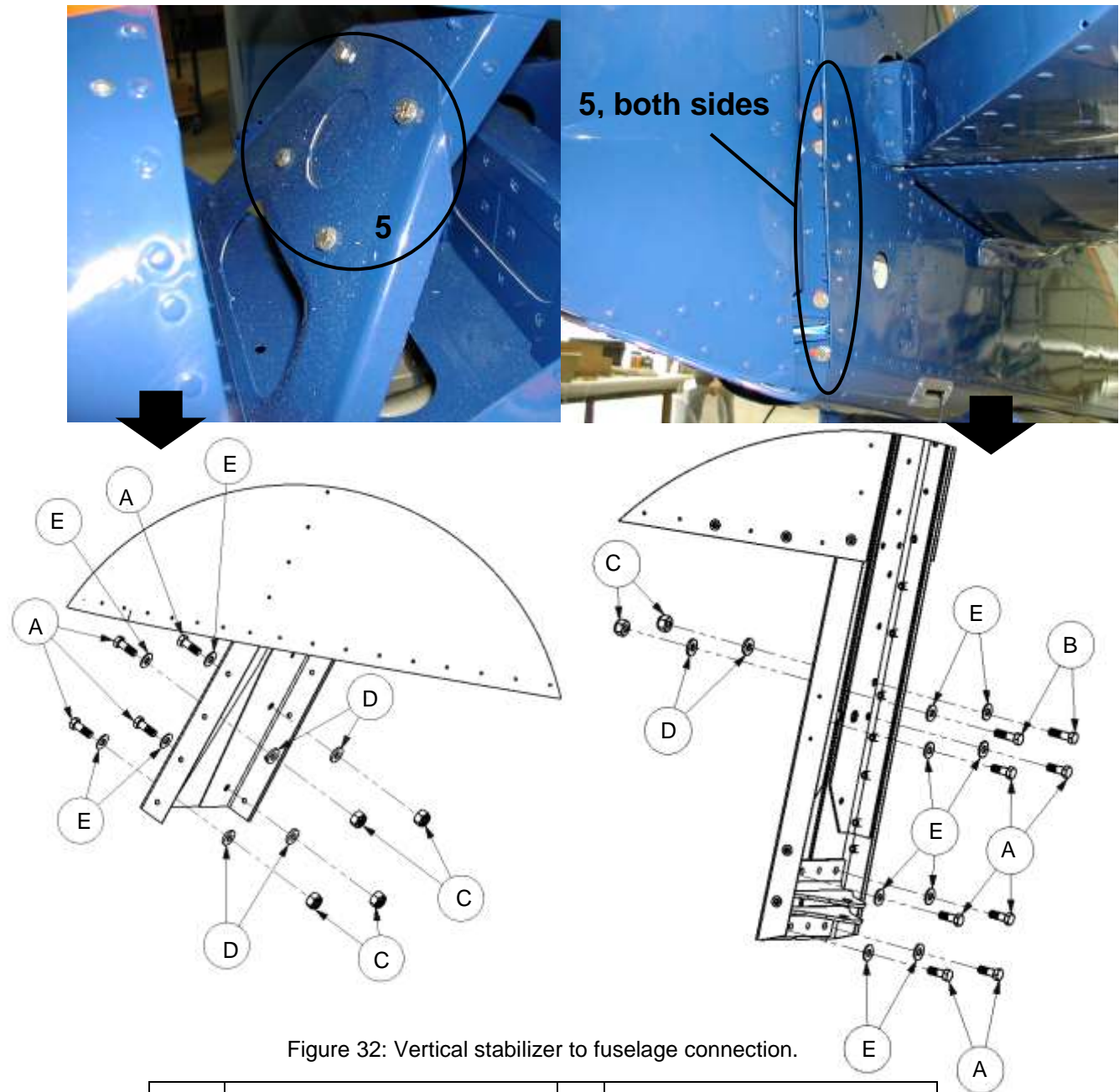

Figure 32: Vertical stabilizer to fuselage connection.

A	AN3-4A bolt	E	AN3 washer (0.8 mm / 0.032")
B	AN3-5A bolt	Refer to paragraph 7 for hardware designations	
C	AN3 lock-nut (Nyloc)		
D	AN3 washer (1.6 mm / 0.064")		

6. Carefully lift the vertical tail clear from the fuselage.

## PROCEDURE (INSTALLATION)

1. Reverse the above procedure (removal), paying close attention to the following:
  - Inspect all bolts, nuts and screws for damage. Replace if necessary.
  - Do not reuse lock-nuts, lock-washers or split pins, as applicable. Fit new.
  - Observe the correct placement of washers (refer to Figure 32).
  - Tighten the lock-nuts on the bolts retaining the vertical stabilizer sufficiently and note that the front mounting bolts are installed with their heads facing towards the aircraft nose and the rear mounting bolts are installed with their heads facing the rear of the aircraft.
  - Do not over tighten the button head screws.
2. Apply orange creep marks to the bolts and nuts.
3. Verify for alignment.

#### 4.2.2.4 RUDDER PEDAL ADJUSTMENT

TOOLS / EQUIPMENT REQUIRED		
ITEM	QUANTITY	NOTES
1	3/8 Spanner.	2
The above list is not necessarily a complete list of all required tools and equipment needed. A calibrated torque wrench (with adequate range) and the correct size (as implied by the above tool list) accessories (sockets etc.) are implied for torquing bolts / nuts, if applicable. Refer to paragraph 1.5 for torque values.		
AUTHORISED PERSONNEL		
Any person performing maintenance of any kind on the aircraft or any component thereof must do so in accordance with national legislation. This is the responsibility of the aircraft owner and any person who is to perform any maintenance on the aircraft.		

#### PROCEDURE (ADJUSTMENT)

Retain bolts, spacers, screws and washers (with the exception of lock-washers), as applicable, for reassembly.

1. Undo the bolt and nut (1) securing rudder bar (2) in the pedal tube (3). Slide the rudder bar (2) to the selected position and reinsert the bolt and washer.
2. Do not reuse the lock-nut. Fit new.
3. Tighten the lock-nut.



**4.2.2.5 RUDDER CABLE TENSION ADJUSTMENT**

TOOLS / EQUIPMENT REQUIRED		
ITEM	QUANTITY	NOTES
1	3/8 Spanner.	1
2	½ inch Spanner.	1
3	2 mm Allen key.	1
The above list is not necessarily a complete list of all required tools and equipment needed. A calibrated torque wrench (with adequate range) and the correct size (as implied by the above tool list) accessories (sockets etc.) are implied for torquing bolts / nuts, if applicable. Refer to paragraph 1.5 for torque values.		
CONSUMABLE MATERIAL REQUIRED		
ITEM	QUANTITY	NOTES
1	Orange paint.	As needed.
2	Loctite 222.	As needed. Inspection panels screws.
The above list is not necessarily a complete list of all material needed. Refer to the Sling 2 construction manual.		
AUTHORISED PERSONNEL		
Any person performing maintenance of any kind on the aircraft or any component thereof must do so in accordance with national legislation. This is the responsibility of the aircraft owner and any person who is to perform any maintenance on the aircraft.		

**CAUTION**

**BE PREPARED WITH A HELPER OR SUPPORT STAND TO HANDLE THE WEIGHT AND / OR AWKWARDNESS OF THE OBJECT (SEAT) TO BE REMOVED.**

## PROCEDURE (ADJUSTMENT)

Retain bolts, spacers, screws and washers (with the exception of lock-washers), as applicable, for reassembly.

1. Remove the seats (refer to paragraph 4.3.2.1).
2. Remove the inspection panels in the baggage compartment floor.
3. Support the aircraft such that the nose wheel is in the air. The nose gear strut must swivel freely.
4. Make sure that the stops (in the centre between the pedals) on the pedals are working correctly and stop the pedal travel approximately equally left and right. Also make sure that the stops cannot hook on the attaching bolts (there must be a minimum of a 3 mm clearance to the bolt heads), otherwise the rudder could get jammed.
5. Undo the bolts (1) retaining the springs (2) to the fuselage, remove the bolts and washers and free the ends of the springs.

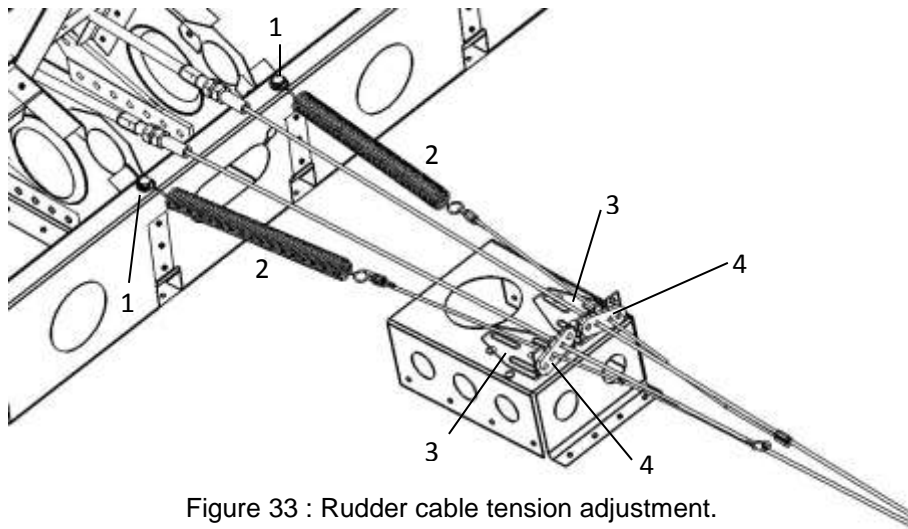

Figure 33 : Rudder cable tension adjustment.

6. Verify that when the rudder is in line with the vertical stabilizer, the pedals are in line with each other. With the rudder lined up with the vertical stabilizer the front wheel must be perfectly straight.
7. Adjust the tension on the rudder cables and the front wheel alignment by adjusting the two pedal pushrods. The rudder cables must not be so tight as to impede movement, but also not so loose that it hangs.
8. Tighten the lock-nuts on the two pedal / front steering pushrods.
9. Reconnect the springs (2) onto the fuselage with the applicable bolts and washers.



10. Loosen the screws on the angled brackets (3), adjust the brackets so that when the rudder is straight the cable stops (4) are hard against the angled brackets. Tighten the screws.
11. Verify that with the rudder centred there is only a very slight tension on the rear part of the rudder cable.
12. Paint orange creep marks on the pushrod lock-nuts.
13. Ensure no foreign objects or tools are left behind. Close the inspection panels. Refit the seats.

## 4.3 FUSELAGE

### 4.3.1 REAR FUSELAGE

The aft part of the fuselage (tail cone) is an aluminium alloy semi-monocoque structure. A number of stringers carry through to the centre fuselage for strength and rigidity. Supporting brackets for the vertical and horizontal stabilisers are attached to the rear formers at the tail section. A cross brace with a guide for the elevator push/pull rod is mounted in the rear fuselage. The forward portion of the rear fuselage contains a luggage packing space with an aluminium skin floor supported by stringers.

#### 4.3.2 CENTRE FUSELAGE

The centre fuselage accommodates the pilot and passenger seating, the flight controls and instrument panel. Seats are removable.

##### 4.3.2.1 SEAT REMOVAL AND INSTALLATION

AUTHORISED PERSONNEL
----------------------

Any person performing maintenance of any kind on the aircraft or any component thereof must do so in accordance with national legislation. This is the responsibility of the aircraft owner and any person who is to perform any maintenance on the aircraft.
---

<b>CAUTION</b>
----------------

<b>BE PREPARED WITH A HELPER OR SUPPORT STAND TO HANDLE THE WEIGHT AND / OR AWKWARDNESS OF THE OBJECT TO BE REMOVED / INSTALLED.</b>
--

### PROCEDURE (REMOVAL)

1. Pull / rotate the lever (1) (located at the front of the seat, in the middle of the centre cut-out) to release / operate the catch mechanism securing the seat to the aircraft.
2. Slide the seat clear of the railings and carefully lift the seat clear of the aircraft.



### PROCEDURE (INSTALLATION)

1. Pull / rotate the lever, fit the seat into place and release the lever.
2. Before flight, verify secure attachment of the seat.

#### 4.3.2.2 CANOPY AND WINDSHIELD CLEANING

**CAUTION**

**Never** clean the canopy / windshield under dry conditions and **never** use petrol, alcohol or chemical solvents.

Never dust the canopy under dry conditions. The canopy and windshield may only be cleaned by washing it with a sufficient quantity of lukewarm water and an adequate quantity of detergents suitable for polymethyl methacrylate (Perspex). Use a soft, clean cloth, sponge or deerskin.

#### 4.3.2.3 UPHOLSTERY CLEANING

Upholstery and covers may be removed from the cockpit / cabin, brushed and eventually washed in lukewarm water with an adequate quantity of detergents. Dry thoroughly before insertion into the cockpit / cabin.

#### 4.3.3 FORWARD FUSELAGE AND FIREWALL

The forward fuselage accommodates the engine mount, engine and firewall forward / firewall mounted equipment and engine cowling.

Refer to paragraph 4 for a schematic showing the equipment (and their positions) mounted on the firewall (engine side).

Refer to paragraph 5.1 with regard to the engine cowling.

Refer to paragraph 5.2 with regard to the engine.

#### 4.4 LANDING GEAR

##### 4.4.1 MAIN GEAR

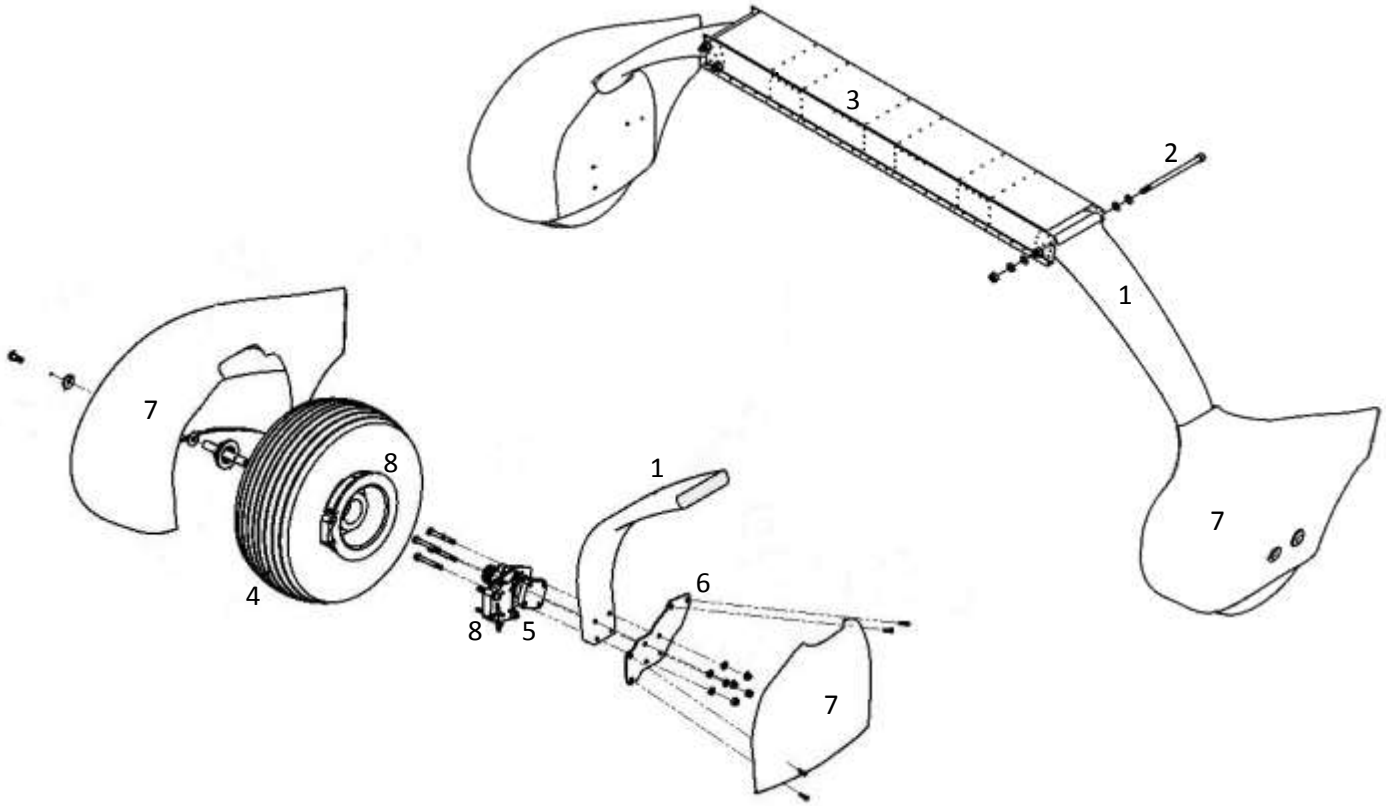

Figure 34: Main landing gear.

Refer to figure Figure 34. Refer to paragraph 1.7. The main landing gear consists of single section composite struts (1) attached (to the fuselage) using four bolts (2) threaded through bushings laid into the struts. Suspension is provided by the flexibility within the struts, which is attached transversely via a channel (3) (designed for purpose) in the lower centre fuselage. Wheels (4) are cantilevered on the main gear struts (1) via axles (5). Mounting plates (6) allow for the attachment of the inner halves of the wheel fairings (7). The system features hydraulically actuated disc brakes (8) controlled by a lever located on the cabin centre console (between the seats).

Wheel fairings / spats (7) round off the main landing gear.

#### 4.4.1.1 MAIN WHEEL FAIRING REMOVAL / INSTALLATION

TOOLS / EQUIPMENT REQUIRED			
ITEM		QUANTITY	NOTES
1	3 mm Allen key / hex drive.	1	
2	2.5 mm Allen key / hex drive.	1	
The above list is not necessarily a complete list of all required tools and equipment needed. A calibrated torque wrench (with adequate range) and the correct size (as implied by the above tool list) accessories (sockets etc.) are implied for torquing bolts / nuts, if applicable. Refer to paragraph 1.5 for torque values.			
CONSUMABLE MATERIAL REQUIRED			
ITEM		QUANTITY	NOTES
1	Loctite 222.	As needed.	Fairing screws.
2	Loctite 243.	As needed.	Bolt retaining wheel fairing to the main axle spacer.
The above list is not necessarily a complete list of all material needed. Refer to the Sling 2 construction manual.			
AUTHORISED PERSONNEL			
Any person performing maintenance of any kind on the aircraft or any component thereof must do so in accordance with national legislation. This is the responsibility of the aircraft owner and any person who is to perform any maintenance on the aircraft.			



## PROCEDURE (REMOVAL)

Retain any bolts, nuts (except lock-nuts) spacers, screws and washers (with the exception of lock-washers) for reassembly.

1. Remove the inside half (1) of the fairing by unscrewing all button head screws (2) that hold the fairing to the support plate and hold the inner and outer fairing sections to one another.

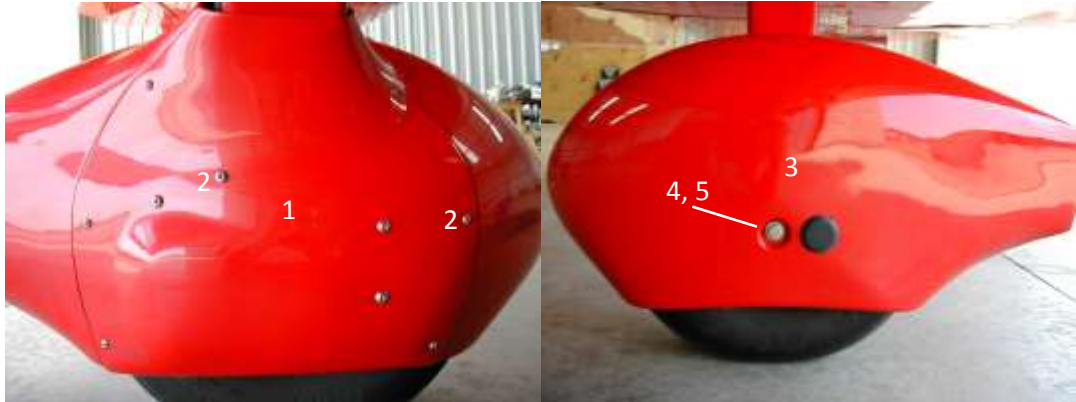

2. Support the outside fairing half (3) and unfasten the retaining bolt (4). Remove the fairing half, bolt and washers (5).

## PROCEDURE (INSTALLATION)

1. Reverse the above procedure for installation, paying careful attention to the following:
  - Avoid damage to the fibreglass fairing(s) and rivnuts by not tightening the button head screws excessively.
  - Apply thread locking sealant to the fairing screws and to the retaining bolt before fitting.

#### 4.4.1.2 MAIN WHEEL REMOVAL / INSTALLATION

TOOLS / EQUIPMENT REQUIRED			
ITEM		QUANTITY	NOTES
1	38 mm Hex socket.	1	
2	Socket wrench + drive (if necessary) to fit item 1.	1	
3	7/16 Spanner.	1	
<p>The above list is not necessarily a complete list of all required tools and equipment needed. A calibrated torque wrench (with adequate range) and the correct size (as implied by the above tool list) accessories (sockets etc.) are implied for torquing bolts / nuts, if applicable. Refer to paragraph 1.5 for torque values.</p>			
CONSUMABLE MATERIAL REQUIRED			
ITEM		QUANTITY	NOTES
1	Split pin.	1	
2	Orange paint.	As needed.	
<p>The above list is not necessarily a complete list of all material needed. Refer to the Sling 2 construction manual.</p>			
AUTHORISED PERSONNEL			
<p>Any person performing maintenance of any kind on the aircraft or any component thereof must do so in accordance with national legislation. This is the responsibility of the aircraft owner and any person who is to perform any maintenance on the aircraft.</p>			

## PROCEDURE (REMOVAL)

Retain any bolts, nuts (except lock-nuts) spacers, screws and washers (with the exception of lock-washers) for reassembly.

1. Remove the main wheel fairing. Refer to paragraph 4.4.1.1.
2. Hoist the aircraft onto supports.
3. Unfasten the two bolts (1) holding the brake callipers together and remove the rear (towards the wheel) calliper assembly (2), which will come away in two parts (3).



4. Remove the split pin (4) and pull out the spacer (5).



5. Unfasten the wheel retaining nut (6). Carefully pull the wheel assembly free from the axle, taking care not to let the two wheel bearings fall out and sustain damage.
6. Drop the two wheel bearings out from the hub assembly. Keep the bearings clear of dust, dirt and moisture.

## PROCEDURE (INSTALLATION)

1. Reverse the above procedure (removal) for installation, paying close attention to the following:

- Inspect all bolts and / or screws for damage. Replace if necessary.
- Inspect the rubber o-rings (1) on the spacer. Replace if necessary.



- Do not reuse lock-washers or split pins. Fit new.
  - Inspect the wheel bearings. Replace if necessary. Grease the bearings before installation (refer to paragraph 4.4.1.5).
  - Tighten the brake caliper retaining nuts sufficiently. Do not over-tighten.
2. Tighten the wheel retaining nut sufficiently and insert the split pin.
3. Paint orange creep marks on the bolts / nuts.
4. Verify free rotation for the wheel.

**4.4.1.3 MAIN WHEEL AXLE AND BRAKE MECHANISM REMOVAL**

TOOLS / EQUIPMENT REQUIRED		
ITEM	QUANTITY	NOTES
1	7/16 Spanner.	2
The above list is not necessarily a complete list of all required tools and equipment needed. A calibrated torque wrench (with adequate range) and the correct size (as implied by the above tool list) accessories (sockets etc.) are implied for torquing bolts / nuts, if applicable. Refer to paragraph 1.5 for torque values.		
CONSUMABLE MATERIAL REQUIRED		
ITEM	QUANTITY	NOTES
1	Orange paint.	As needed.
2	Loctite 577	As needed
Brake line fittings - if decoupled.		
The above list is not necessarily a complete list of all material needed. Refer to the Sling 2 construction manual.		
AUTHORISED PERSONNEL		
Any person performing maintenance of any kind on the aircraft or any component thereof must do so in accordance with national legislation. This is the responsibility of the aircraft owner and any person who is to perform any maintenance on the aircraft.		

## PROCEDURE (REMOVAL)

Retain any bolts, nuts (except lock-nuts) spacers, screws and washers (with the exception of lock-washers) for reassembly.

1. Remove the wheel fairing (refer to paragraph 4.4.1.1).
2. Remove the wheel (refer to paragraph 4.4.1.2).
3. Ensure that the aircraft cannot roll / move (if only one wheel jacked up) and release the park brake.
4. Unfasten and remove the four axle (1), brake mechanism (2) and fairing mounting plate (3) retaining bolts and nuts (4).

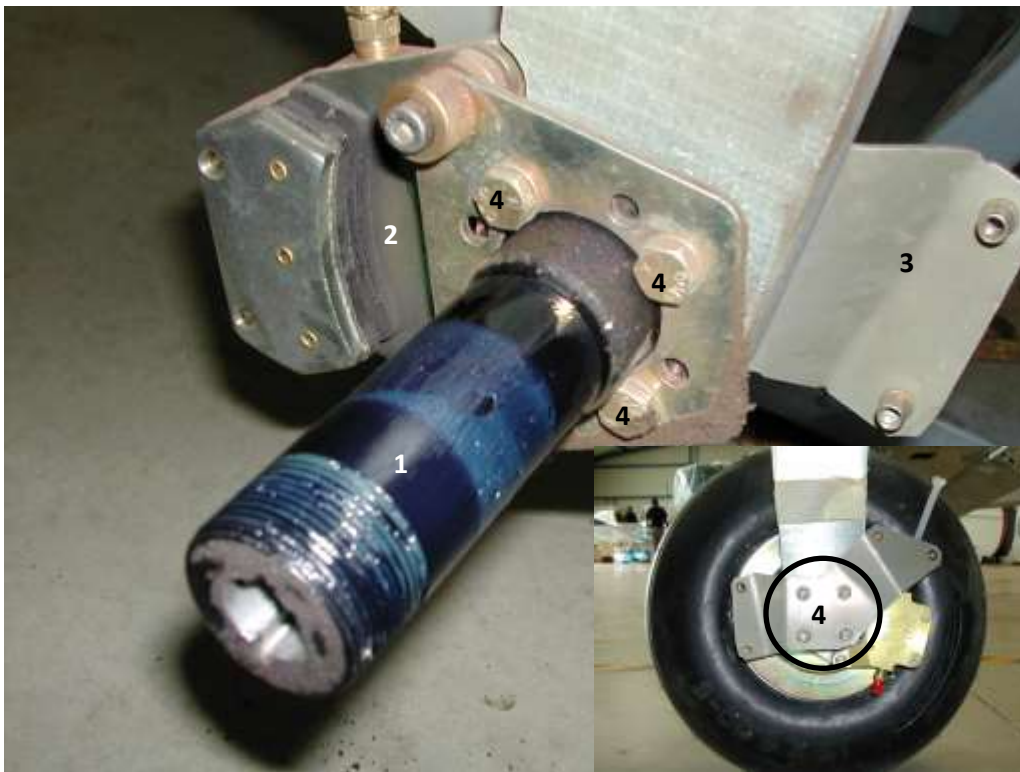

5. If required, the brake mechanism (2) can be disconnected from the brake line (5). Refer to paragraph 9.1 for draining the brake fluid before disconnecting here. Blank off the brake fluid line to prevent drip and spillage.



6. Remove the axle, brake assembly and mounting plate. Slide the axle out from the brake mechanism plate.

### PROCEDURE (INSTALLATION)

1. Reverse the above procedure for reinstallation, paying close attention to the following:
  - Inspect all bolts, nuts and screws for damage. Replace if necessary.
  - Do not reuse lock-nuts and / or lock-washers. Fit new.
  - Tighten the lock-nuts and bolts mounting the axle, brake assembly and fairing mounting plate to the undercarriage strut sufficiently. Observe the correct placement of washers (refer to Figure 35) and note that the bolts are installed with their heads facing the wheel.
2. Apply creep marks to the bolts / nuts with orange paint.

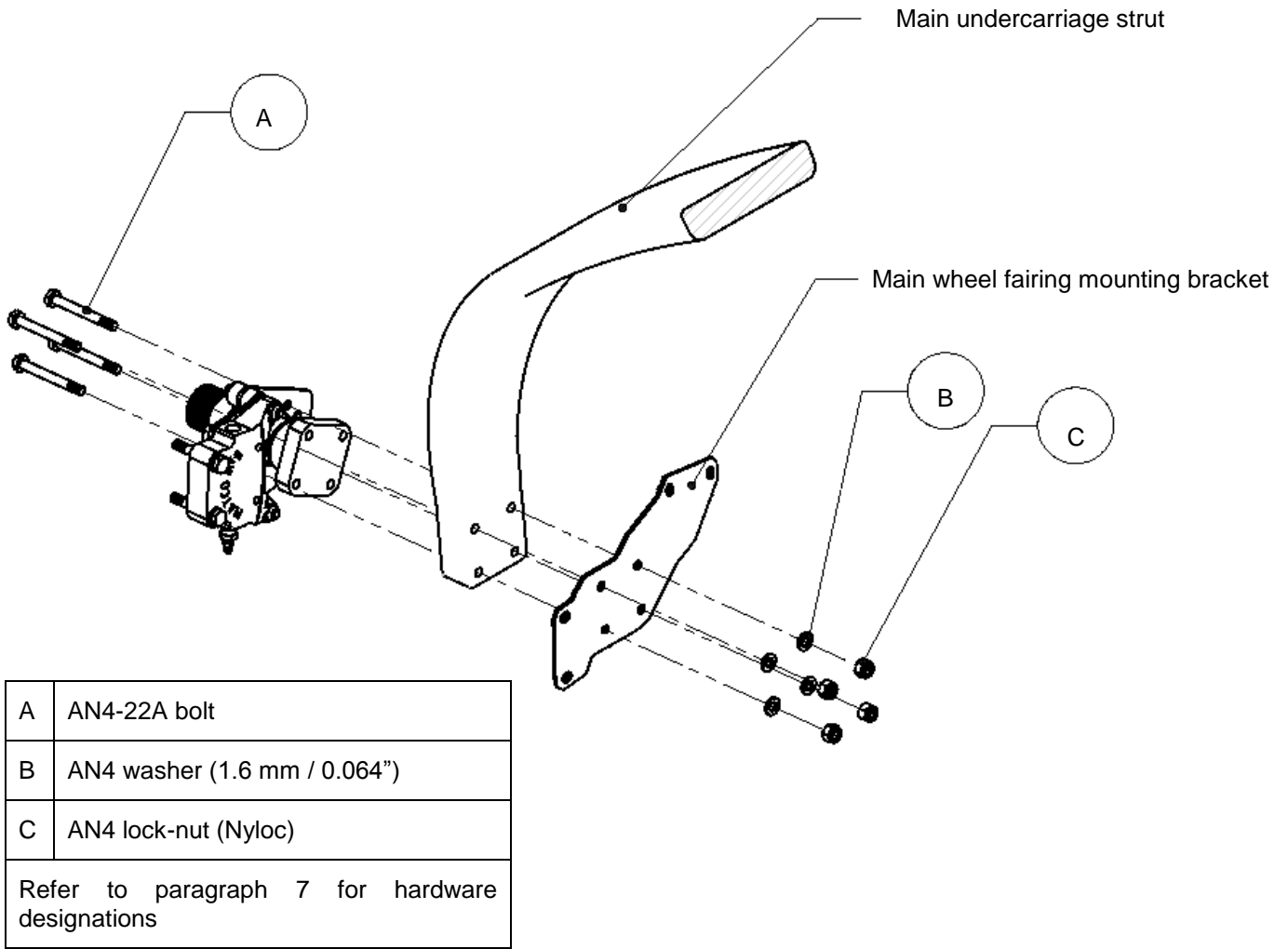

Figure 35: Main wheel axle installation.



#### 4.4.1.4 MAIN WHEEL DISASSEMBLY / ASSEMBLY

TOOLS / EQUIPMENT REQUIRED		
ITEM	QUANTITY	NOTES
1	½ inch Spanner.	1
2	6 mm Allen key / hex drive.	1
3	4 mm Allen key / hex drive.	1
<p>The above list is not necessarily a complete list of all required tools and equipment needed. A calibrated torque wrench (with adequate range) and the correct size (as implied by the above tool list) accessories (sockets etc.) are implied for torquing bolts / nuts, if applicable. Refer to paragraph 1.5 for torque values.</p>		
CONSUMABLE MATERIAL REQUIRED		
ITEM	QUANTITY	NOTES
1	Orange paint.	As needed.
<p>The above list is not necessarily a complete list of all material needed. Refer to the Sling 2 construction manual.</p>		
AUTHORISED PERSONNEL		
<p>Any person performing maintenance of any kind on the aircraft or any component thereof must do so in accordance with national legislation. This is the responsibility of the aircraft owner and any person who is to perform any maintenance on the aircraft.</p>		

## PROCEDURE (DISASSEMBLY)

Retain any bolts, nuts (except lock-nuts) spacers, screws and washers (with the exception of lock-washers) for reassembly.

1. Remove the wheel (refer to paragraph 4.4.1.2).
2. Mark the tyre position on the rim and mark the hub halves for correct realignment during assembly. If not done correctly the wheel could be out of balance after assembly.
3. Deflate the tyre completely.
4. Unfasten the screws (1) retaining the brake disc (2) to the brake disc spacer (3), to separate the brake disc from the hub.



**NOTE: Tyre not shown mounted on hub in this photograph.**

5. Unfasten and remove the bolts and nuts clamping the two wheel hub halves and brake disc spacer together. To separate the inner tube, tyre and o-ring from the hubs, carefully pull the two hub halves apart, taking care not to damage the valve stem as it pulls out of the hole in the one half.

## PROCEDURE (ASSEMBLY)

In the procedure below, align according to the marks made during disassembly.

1. Remove the valve cap. Inflate the inner tube slightly to give it shape and insert into the tyre.
2. Seat the tyre (with inner tube inside) on the wheel hub half with the cut-out for the valve tube, taking care that the valve tube fits properly through the cut-out.
3. Move the other wheel hub half into position. Secure the two wheel hub halves and brake disc spacer together. Tighten the bolts sufficiently. Take care not to catch the inner tube between the two hub halves.
4. Inspect the o-ring for damage. Replace if necessary.
5. Push the wheel to one side of the assembled wheel hub, slip the o-ring over the other side of the assembled wheel hub and into place in the groove between the two hub halves.
6. Secure the brake disc to the assembled wheel hub / brake disc spacer. Tighten the button head screws sufficiently.
7. Inflate the tyre to 2.8 bar to make it seat properly and then deflate the tyre to normal pressure. Refer to paragraph 1.7 for tyre pressures.
8. Replace the valve cap.
9. Inspect for air leaks.
10. Paint orange creep marks on the bolts and nuts.
11. Index (i.e. apply creep marks) the tyre with the wheel rim to enable the detection of tyre slippage.

**4.4.1.5 MAIN WHEEL BEARING REMOVAL / INSTALLATION AND LUBRICATION**

CONSUMABLE MATERIAL REQUIRED			
ITEM		QUANTITY	NOTES
1	Grease.	As needed.	Refer to paragraph 1.4.
2	Solvent to clean bearings.	As needed.	Refer to paragraph 1.4.
The above list is not necessarily a complete list of all material needed. Refer to the Sling 2 construction manual.			
AUTHORISED PERSONNEL			
Any person performing maintenance of any kind on the aircraft or any component thereof must do so in accordance with national legislation. This is the responsibility of the aircraft owner and any person who is to perform any maintenance on the aircraft.			

**PROCEDURE**

1. Remove the main wheel(s) to obtain the bearing(s). Refer to paragraph 4.4.1.2.
2. Clean the bearing(s) with solvent.
3. Apply grease. Do not grease excessively.
4. Install the bearing(s) and wheel(s). Refer to paragraph 4.4.1.2.

**4.4.1.6 MAIN GEAR REMOVAL / INSTALLATION**

TOOLS / EQUIPMENT REQUIRED			
	ITEM	QUANTITY	NOTES
1	1 x 4 mm and 1 x 3.2 mm Drill bits with driver (electric or hand drill).	1 Set	Removal.
2	17 mm Spanner.	1	
3	8 mm Allen key.	1	
4	7/16 Spanner.	1	
5	2 mm Allen key / hex drive.	1	
6	Blind rivet tool.	1	Installation.
7	<u>Calibrated</u> torque wrench with at least 25 Nm range.	1	Installation.
8	17 mm Hex socket.	1	To fit item 7.
CONSUMABLE MATERIAL REQUIRED			
	ITEM	QUANTITY	NOTES
1	Orange paint.	As needed.	
2	Loctite 222.	As needed.	Inspection panel screws.
3	4 mm x 10 mm Aluminium blind rivets (multi-grip).	As needed.	Undercarriage channel cover plate.
4	3.2 mm x 8 mm Aluminium blind rivets (multi-grip).	As needed.	Undercarriage channel cover plate.
5	Glue (PRATLEY QUICKSET CLEAR)	As needed.	To glue brake line(s) into undercarriage leg groove. Mix glue according to manufacturer instructions.
5	Loctite 577.	As needed.	Brake line fittings.
The above list is not necessarily a complete list of all material needed. Refer to the Sling 4 construction manual.			
AUTHORISED PERSONNEL			
Any person performing maintenance of any kind on the aircraft or any component thereof must do so in accordance with national legislation. This is the responsibility of the aircraft owner and any person who is to perform any maintenance on the aircraft.			

**CAUTION**  
**BE PREPARED WITH A HELPER OR SUPPORT STAND TO HANDLE THE WEIGHT AND / OR AWKWARDNESS OF THE OBJECT TO BE REMOVED / INSTALLED.**

## PROCEDURE (REMOVAL)

Note: The procedure below describes removing the main gear with the main wheels attached. That would necessitate disconnecting the brake pipes from the brake assembly and separating the lines from the strut. The main wheel assemblies (wheel, brake assembly and axle) can be removed (from the strut) before the strut is dropped out from the aircraft, which does not require the disconnection of the brake pipes at the brake assembly, but do require the separation of the brake lines from the strut. Refer to paragraph 4.4.1.3.

Retain any bolts, nuts (except lock-nuts) spacers, screws and washers (with the exception of lock-washers) for reassembly.

1. Hoist the aircraft onto supports. If necessary, balance the sideways movement of the aircraft by placing padded stands under the wings at the hard points (the main spars).
2. Remove the seats (refer to paragraph 4.3.2.1).
3. Release the brake pressure and drain the brake fluid (refer to paragraph 9.1).
4. Disconnect the brake lines (1) at the brake assembly (2).



5. Carefully separate the brake lines from the glue securing the brake line to the grooves in the undercarriage legs.
6. Drill out the rivets retaining the main gear cover plate on the bottom aircraft fuselage.
7. Support the main gear assembly and undo and remove the four bolts and nuts (4) retaining the gear to the aircraft.
8. Drop down the gear underneath the aircraft.

## PROCEDURE (INSTALLATION)

1. Reverse the above procedure (removal), paying close attention to the following:
  - Inspect all bolts, nuts and screws for damage. Replace if necessary.
  - Do not reuse the lock-nuts. Fit new.
  - Torque the bolts / lock-nuts to the correct value (refer to paragraph 1.5.2), observe the correct placement of washers (refer to Figure 36 and Figure 37) and note that the bolts are installed with the bolt heads head facing towards the tail of the aircraft.
  - Clean old glue residue from the undercarriage leg grooves and brake lines before glueing the brake lines back into place. Allow adequate time for the glue to dry.
  - Apply thread locking sealant to the brake line fittings before connecting.
2. Paint creep marks on the bolts and nuts.

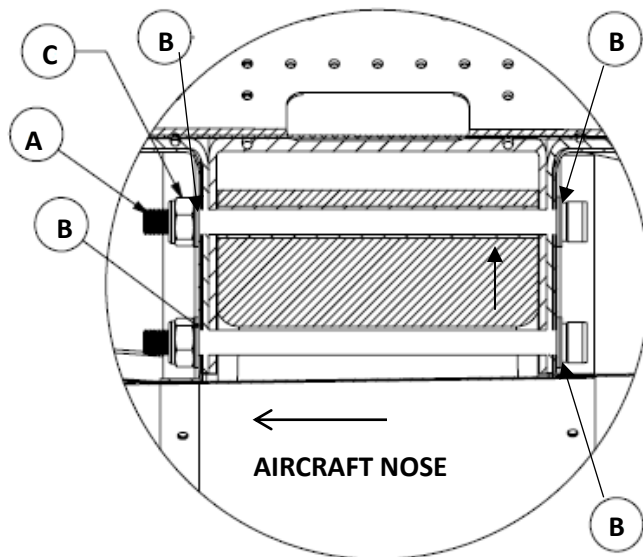

A	M10 x 170 mm bolt, Class 12.9
B	M10 washer
C	M10 lock-nut (Nyloc)
Refer to paragraph 7 for hardware designations	

Figure 36: Main gear installation (no parachute).



The BRS parachute strap is not shown for clarity. The strap fits around item C in the drawing below.

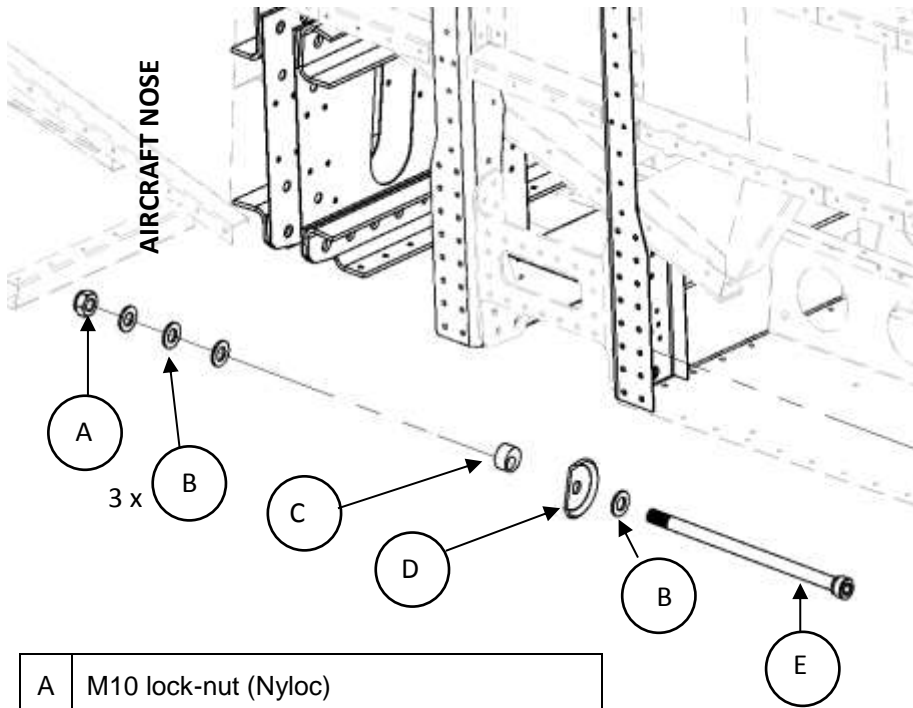

A	M10 lock-nut (Nyloc)
B	M10 washer
C	Parachute cable bush
D	10 mm ID modified cup washer
E	M10 x 185 mm Allen cap bolt, Class 12.9
Refer to paragraph 7 for hardware designations	

Figure 37: Main gear installation (with parachute).

#### 4.4.2 NOSE GEAR

Refer to Figure 38. Refer to paragraph 1.7.

The nose gear strut is attached to the engine mount (1) with two guide brackets (2). A circular spring (3) provides suspension. The steel strut attaches to a conventional U-shaped fork (4) supporting an axle bolt (5). The front wheel (6) is not fitted with a braking mechanism. Steering motion is transmitted from the rudder pedal control horns through two adjustable pushrods attached to the nose gear strut by means of two control horns. Ease of steering movement (both on the ground and in the air) is ensured through the use of three needle roller bearings on the weight bearing surfaces of the strut.

A wheel fairing (7) rounds off the nose gear assembly.

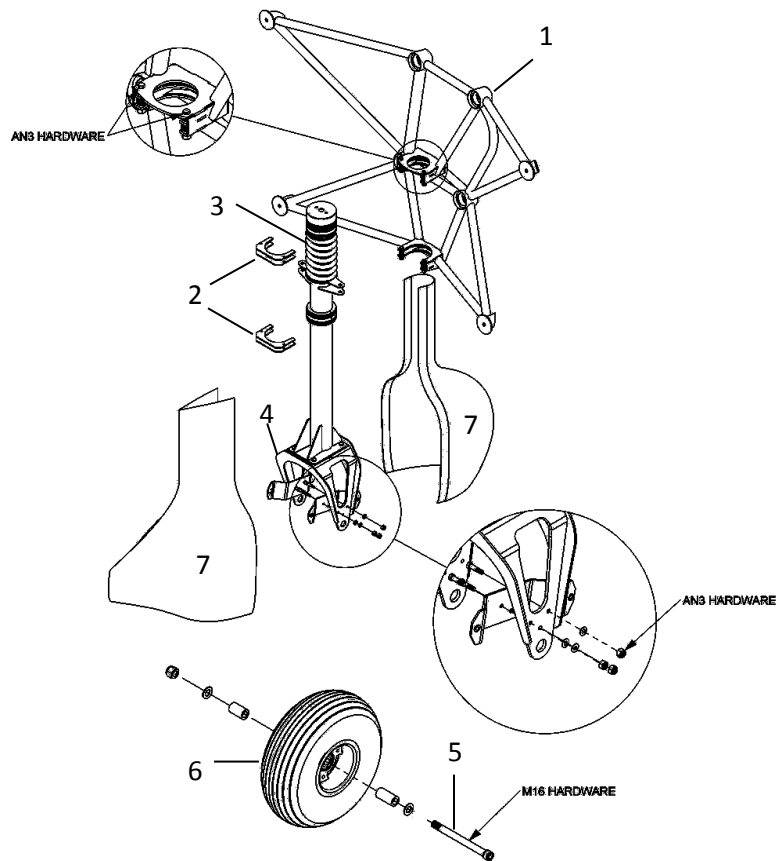

Figure 38: Nose gear.

#### 4.4.2.1 NOSE WHEEL FAIRING REMOVAL / INSTALLATION

TOOLS / EQUIPMENT REQUIRED		
ITEM	QUANTITY	NOTES
1	3 mm Allen key / hex drive.	1
2	2.5 mm Allen key / hex drive.	1
The above list is not necessarily a complete list of all required tools and equipment needed. A calibrated torque wrench (with adequate range) and the correct size (as implied by the above tool list) accessories (sockets etc.) are implied for torquing bolts / nuts, if applicable. Refer to paragraph 1.5 for torque values.		
CONSUMABLE MATERIAL REQUIRED		
ITEM	QUANTITY	NOTES
1	Loctite 222.	As needed. Fairing screws.
The above list is not necessarily a complete list of all material needed. Refer to the Sling 2 construction manual.		
AUTHORISED PERSONNEL		
Any person performing maintenance of any kind on the aircraft or any component thereof must do so in accordance with national legislation. This is the responsibility of the aircraft owner and any person who is to perform any maintenance on the aircraft.		

#### PROCEDURE (REMOVAL)

Retain any bolts, nuts (except lock-nuts) spacers, screws and washers (with the exception of lock-washers) for reassembly.

1. Separate the front and rear halves of the nose wheel fairing by unscrewing the button head screws retaining the halves to each other and to the brackets on the nose gear.

#### PROCEDURE (INSTALLATION)

1. Reverse the above procedure (removal), paying close attention to the following:

- Inspect all bolts and / or screws for damage. Replace if necessary.
- Prevent damage to the fibreglass fairings and rivnuts by not tightening the button head screws excessively.

#### 4.4.2.2 NOSE WHEEL REMOVAL / INSTALLATION

TOOLS / EQUIPMENT REQUIRED		
ITEM	QUANTITY	NOTES
1	14 mm Allen key / hex drive.	1
2	24 mm Spanner.	1
<p>The above list is not necessarily a complete list of all required tools and equipment needed. A calibrated torque wrench (with adequate range) and the correct size (as implied by the above tool list) accessories (sockets etc.) are implied for torquing bolts / nuts, if applicable. Refer to paragraph 1.5 for torque values.</p>		
CONSUMABLE MATERIAL REQUIRED		
ITEM	QUANTITY	NOTES
1	Orange paint.	As needed.
<p>The above list is not necessarily a complete list of all material needed. Refer to the Sling 2 construction manual.</p>		
AUTHORISED PERSONNEL		
<p>Any person performing maintenance of any kind on the aircraft or any component thereof must do so in accordance with national legislation. This is the responsibility of the aircraft owner and any person who is to perform any maintenance on the aircraft.</p>		

## PROCEDURE (REMOVAL)

Retain any bolts, nuts (except lock-nuts) spacers, screws and washers (with the exception of lock-washers) for reassembly.

1. Remove the nose wheel fairing. Refer to paragraph 4.4.2.1.
2. Lift and support the front of aircraft in such a manner as to lift the nose wheel off the ground.
3. Unfasten the lock-nut (1) retaining the nose wheel.



4. Support the wheel and remove the axle bolt (2), washers (3) and the two bushes / spacers (4).



5. Remove the wheel from the fork (5).

## PROCEDURE (INSTALLATION)

1. Reverse the above procedure (removal), paying close attention to the following:

- Inspect all bolts, nuts and screws for damage. Replace if necessary.
- Do not reuse the lock-nut. Fit new.
- Take care to place / align the spacers correctly so as not to bend them the when tightening the lock-nut.
- Observe the correct placement of washers and bushes and the correct orientation of the nose wheel (refer to Figure 39). Note that the lock-nut faces the starboard side of the aircraft.

A	M16 x 175 mm Allen cap bolt, Class 12.9
B	M16 washer
C	Bush (long)
D	Bush (short)
E	M16 lock-nut (Nyloc)

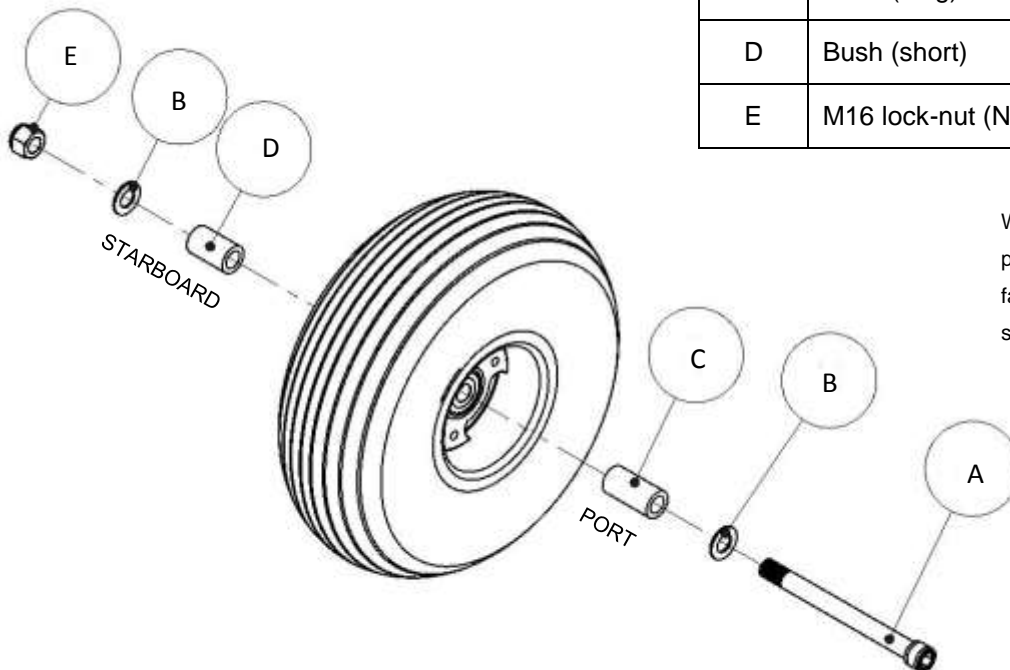

Wheel is mounted in the fork with the 3-pointed flange (1) of the bearing mount facing the port side (i.e. the valve facing starboard).

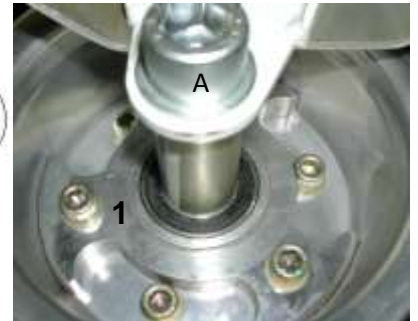

Figure 39: Nose wheel installation.

- Tighten the lock-nut sufficiently.
2. Paint orange creep marks on the bolt and nut.
  3. Verify free rotation for the wheel.

#### 4.4.2.3 NOSE WHEEL DISASSEMBLY / ASSEMBLY

TOOLS / EQUIPMENT REQUIRED		
ITEM	QUANTITY	NOTES
1	14 mm Allen key / hex drive.	1
2	13 mm Spanner.	1
<p>The above list is not necessarily a complete list of all required tools and equipment needed. A calibrated torque wrench (with adequate range) and the correct size (as implied by the above tool list) accessories (sockets etc.) are implied for torquing bolts / nuts, if applicable. Refer to paragraph 1.5 for torque values.</p>		
CONSUMABLE MATERIAL REQUIRED		
ITEM	QUANTITY	NOTES
1	Orange paint.	As needed.
<p>The above list is not necessarily a complete list of all material needed. Refer to the Sling 2 construction manual.</p>		
AUTHORISED PERSONNEL		
<p>Any person performing maintenance of any kind on the aircraft or any component thereof must do so in accordance with national legislation. This is the responsibility of the aircraft owner and any person who is to perform any maintenance on the aircraft.</p>		

## PROCEDURE (DISASSEMBLY)

Retain any bolts, nuts (except lock-nuts) spacers, screws and washers (with the exception of lock-washers) for reassembly.

1. Remove the wheel (refer to paragraph 4.4.2.2).
2. Mark the tyre position on the rim and mark the hub halves for correct realignment during assembly. If not done correctly the wheel could be out of balance after assembly.
3. Deflate the tyre completely.
4. Unfasten and remove the bolts clamping the two wheel hub halves and bearing mount assembly together.
5. Pull out the bearing mount assembly.
6. Remove the valve cap (1). To separate the inner tube, tyre and o-ring from the hubs, carefully pull the two hub halves apart, taking care not to damage the valve stem as it pulls out of the cut-out in the one hub half.

## PROCEDURE (ASSEMBLY)

In the procedure below, align according to the marks made during disassembly.

1. Remove the valve cap (1). Inflate the inner tube slightly to give it shape and insert into the tyre.
2. Seat the tyre (with inner tube inside) on the wheel hub half with the cut-out (2) for the valve stem (3), taking care that the valve stem fits properly through the cut-out.



3. Move the other wheel hub half into position and insert the bearing mount assembly through the centre of the two halves, from the side of the hub not supporting the valve stem.



4. Secure the two wheel hub halves and bearing mount assembly together. Take care not to catch the inner tube between the two hub halves. Observe correct placement of washers. Note that the nuts are on the side of the valve. Tighten the bolts / nuts sufficiently.
5. Inspect the o-ring for damage. Replace if necessary.
6. Push the wheel to one side of the assembled wheel hub, slip the o-ring over the other side of the assembled wheel hub and into place in the groove between the two hub halves.
7. Inflate the tyre to approximately 2.5 Bar to make it seat properly and then deflate to normal pressure. Refer to paragraph 1.7 for tyre pressures.
8. Replace the valve cap.
9. Inspect for leaks.
10. Paint orange creep marks on the bolts and nuts.
11. Index (i.e. apply creep marks) the tyre with the wheel rim to enable the detection of tyre slippage.

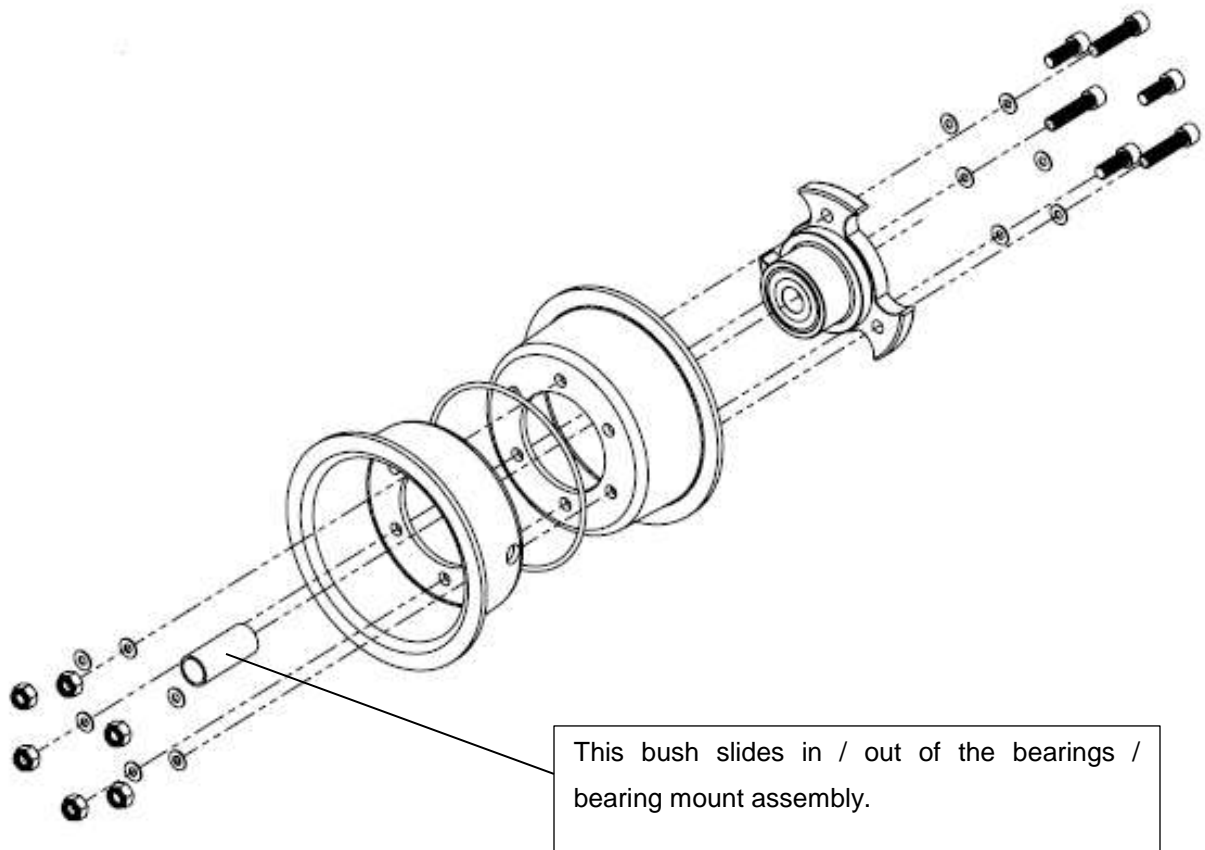

Figure 40: Front wheel hub assembly.

#### 4.4.2.4 NOSE WHEEL BEARING REMOVAL / REPLACEMENT

TOOLS / EQUIPMENT REQUIRED		
ITEM	QUANTITY	NOTES
1	Suitable press for bearings.	1
<p>The above list is not necessarily a complete list of all required tools and equipment needed. A calibrated torque wrench (with adequate range) and the correct size (as implied by the above tool list) accessories (sockets etc.) are implied for torquing bolts / nuts, if applicable. Refer to paragraph 1.5 for torque values.</p>		
AUTHORISED PERSONNEL		
<p>Any person performing maintenance of any kind on the aircraft or any component thereof must do so in accordance with national legislation. This is the responsibility of the aircraft owner and any person who is to perform any maintenance on the aircraft.</p>		

#### PROCEDURE (REMOVAL)

1. Disassemble the wheel (refer to paragraph 4.4.2.3).
2. Push out the bush (refer to Figure 40).
3. Tap the bearings out of the bearing mount.

#### PROCEDURE (INSTALLATION)

1. Inspect the bush for damage. Replace if necessary.
2. Press the bearings into the bearing mount,
3. Insert the bush (Figure 40).

#### 4.4.2.5 NOSE GEAR REMOVAL / INSTALLATION

TOOLS / EQUIPMENT REQUIRED		
ITEM	QUANTITY	NOTES
1	3/8 Spanner.	2
2	7/16 Spanner.	1
3	½ inch Spanner.	2
<p>The above list is not necessarily a complete list of all required tools and equipment needed. A calibrated torque wrench (with adequate range) and the correct size (as implied by the above tool list) accessories (sockets etc.) are implied for torquing bolts / nuts, if applicable. Refer to paragraph 1.5 for torque values.</p>		
AUTHORISED PERSONNEL		
<p>The above list is not necessarily a complete list of all required tools and equipment needed. A calibrated torque wrench (with adequate range) and the correct size (as implied by the above tool list) accessories (sockets etc.) are implied for torquing bolts / nuts, if applicable. Refer to paragraph 1.5 for torque values.</p>		

**WARNING**  
**MASTER / IGNITION SWITCHES OFF.**

**WARNING**

**ALLOW THE ENGINE AND APPLICABLE COMPONENTS TO COOL COMPLETELY BEFORE PERFORMING ANY WORK OR INSPECTION IN THE ENGINE COMPARTMENT. HOT ENGINE COMPONENTS CAN CAUSE SERIOUS BURNS AND CAN IGNITE SPILLED FLUID / VAPOUR.**

**CAUTION**

**BE PREPARED WITH A HELPER OR SUPPORT STAND TO HANDLE THE WEIGHT AND / OR AWKWARDNESS OF THE OBJECT TO BE REMOVED / INSTALLED.**

## PROCEDURE (REMOVAL)

Retain any bolts, nuts (except lock-nuts) spacers, screws and washers (with the exception of lock-washers) for reassembly.

1. Remove the cowling around the engine area (refer to paragraph 5.1.1).
2. Hoist the aircraft onto supports.
3. Disconnect the two rudder pushrods (1) by loosening the bolts (2) through the rod-end bearings.
4. Support the nose gear and undo and remove the bolts, nuts (3) and washers on the bottom nose gear-to-engine mount attachment (4). Remove the two brackets (5).

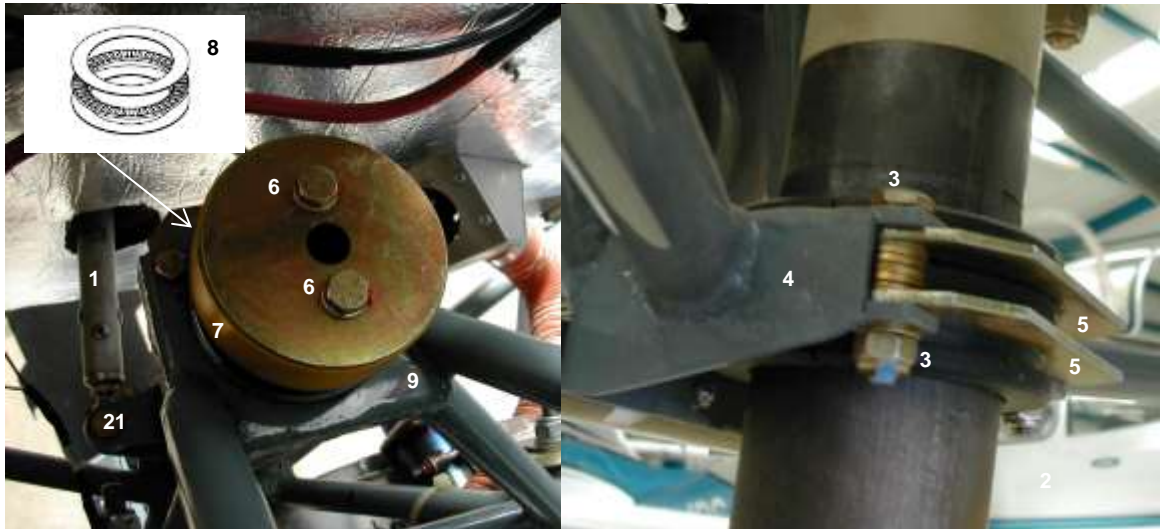

5. Support the nose gear, loosen the bolts (6) and remove the bolts and washers, the spacer (7) and the bearing (8) underneath. Take care not to let the nose gear fall down and strike the rudder control horns against the bottom engine mount connection.
6. Drop the nose gear out / clear from the top engine mount connection (9), pull it (backward) out from the bottom engine mount connection and drop it out underneath the aircraft. The spring and the two lower bearings will remain around the nose gear tube. The bottom bush will split into two pieces.

**PROCEDURE (INSTALLATION)**

1. Reverse the above procedure (removal), paying close attention to the following:

- Inspect all bolts, nuts and screws for damage. Replace if necessary.
- Do not reuse lock-nuts. Fit new.
- Tighten the lock-nuts sufficiently, observe the correct placement of washers and bearings (refer to Figure 41) and note that the bolts are installed with the bolt heads head facing up.

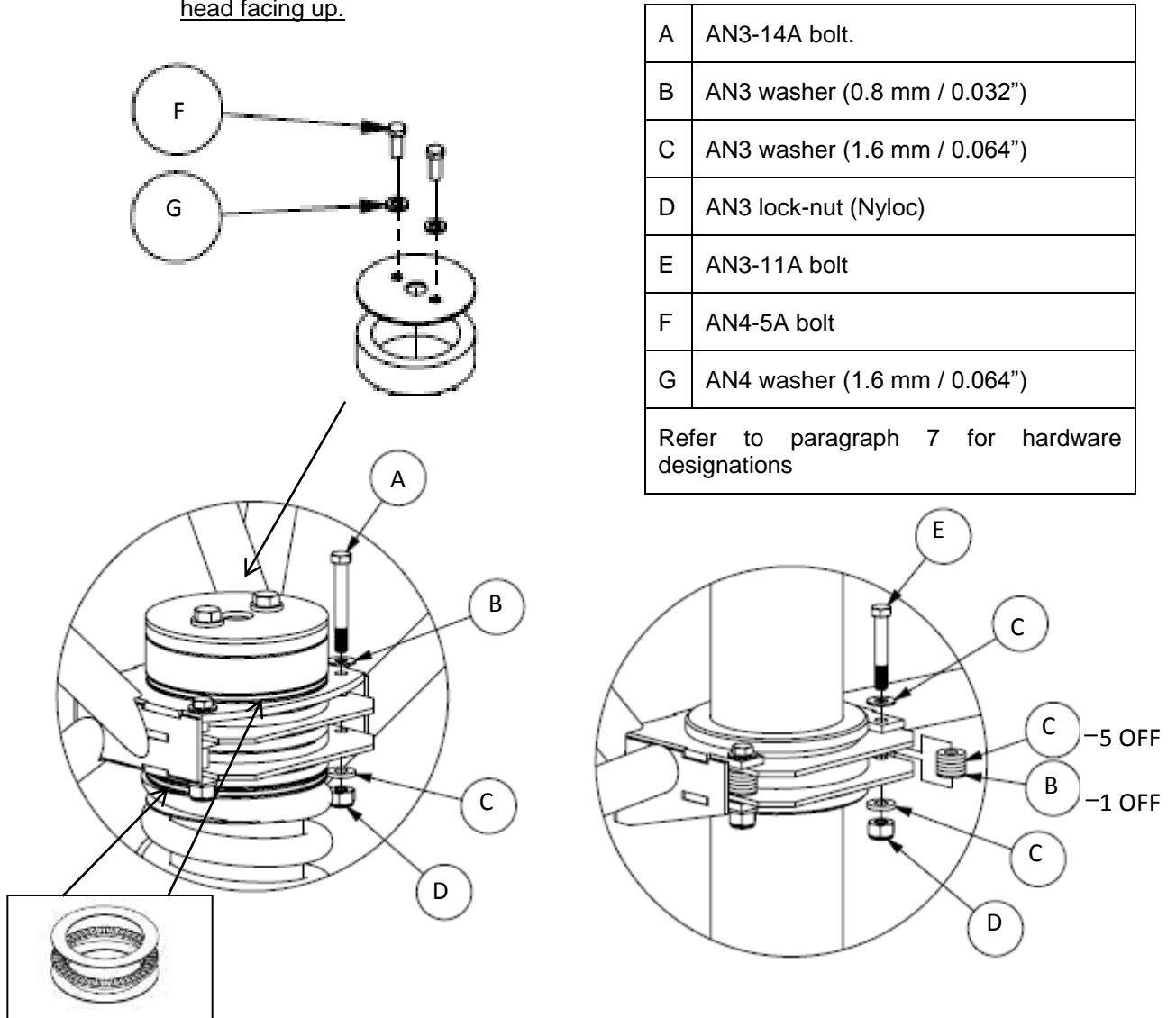

Figure 41: Nose gear installation.

## 5. POWER PLANT

This section provides a general description of the power plant section, comprising of the engine, the propeller, radiators and the cowling surrounding it, and provides descriptions of service and maintenance procedures applicable to the power plant and its subsystems.

### 5.1 COWLING

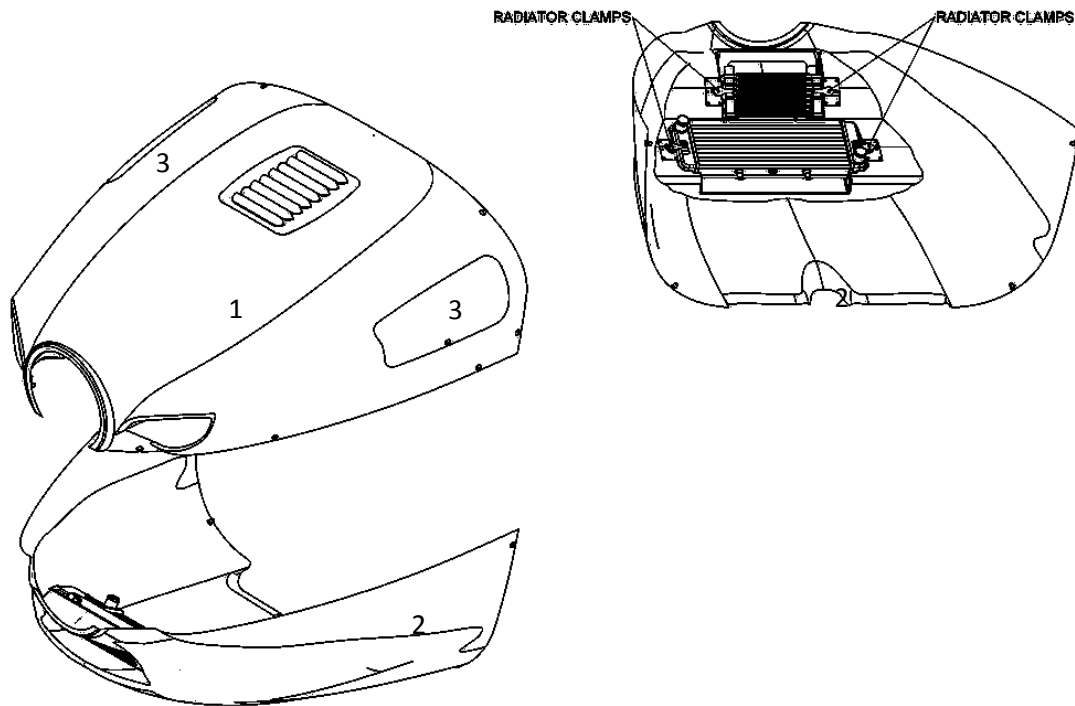

Figure 42: Engine cowling.

Refer to Figure 42. The engine cowling is made up of moulded fibreglass upper (1) and lower (2) parts. Inspection panels (3) are located in the top cowling and are secured down by two Dzus fasteners. The cowling houses the engine, air filter, coolant radiator, oil radiator and oil reservoir. Air to the air filter is provided through the starboard side intake. Circulation over the engine is provided by the front nose intakes. Additional circulatory air is supplied through the coolant and oil radiators. The outflow area is on the underside of the cowling, by the firewall.

**5.1.1 COWLING REMOVAL / INSTALLATION**

TOOLS / EQUIPMENT REQUIRED		
ITEM	QUANTITY	NOTES
1	Flat screwdriver.	1
2	5/16 Spanner.	1
3	3 mm Allen key / hex drive.	1
<p>The above list is not necessarily a complete list of all required tools and equipment needed. A calibrated torque wrench (with adequate range) and the correct size (as implied by the above tool list) accessories (sockets etc.) are implied for torquing bolts / nuts, if applicable. Refer to paragraph 1.5 for torque values.</p>		
AUTHORISED PERSONNEL		
<p>Any person performing maintenance of any kind on the aircraft or any component thereof must do so in accordance with national legislation. This is the responsibility of the aircraft owner and any person who is to perform any maintenance on the aircraft.</p>		

**WARNING**  
**TURN OFF MASTER / IGNITION SWITCHES.**

**WARNING**  
  
**ALLOW THE ENGINE AND APPLICABLE COMPONENTS TO COOL COMPLETELY BEFORE PERFORMING ANY WORK OR INSPECTION IN THE ENGINE COMPARTMENT. HOT ENGINE COMPONENTS CAN CAUSE SERIOUS BURNS AND CAN IGNITE SPILLED FLUID / VAPOUR.**

**CAUTION**  
  
**BE PREPARED WITH A HELPER OR SUPPORT STAND TO HANDLE THE WEIGHT AND / OR AWKWARDNESS OF THE OBJECT TO BE REMOVED / INSTALLED.**

## PROCEDURE (REMOVAL)

### TOP COWL:

1. Release the eight Dzus fasteners located on the sides of the top cowling.
2. Release the four Dzus fasteners located on the top of the top cowling, along the upper edge of the firewall.
3. Once all Dzus fasteners are loose, remove the front and then side fasteners from their seating holes prior to removing those over the firewall.

### BOTTOM COWL:

1. Remove the top cowl (refer to above procedure).
2. Disconnect the air filter supply pipe (1) from the cowl side inlet (2) by loosening the clamp (3) securing it to the inlet.
3. Alternatively, loosen the clamp securing the air pipe at the air filter box.





4. Release the four catches (4), one on each side of the coolant (5) and oil radiators (6). Also refer to Figure 42.

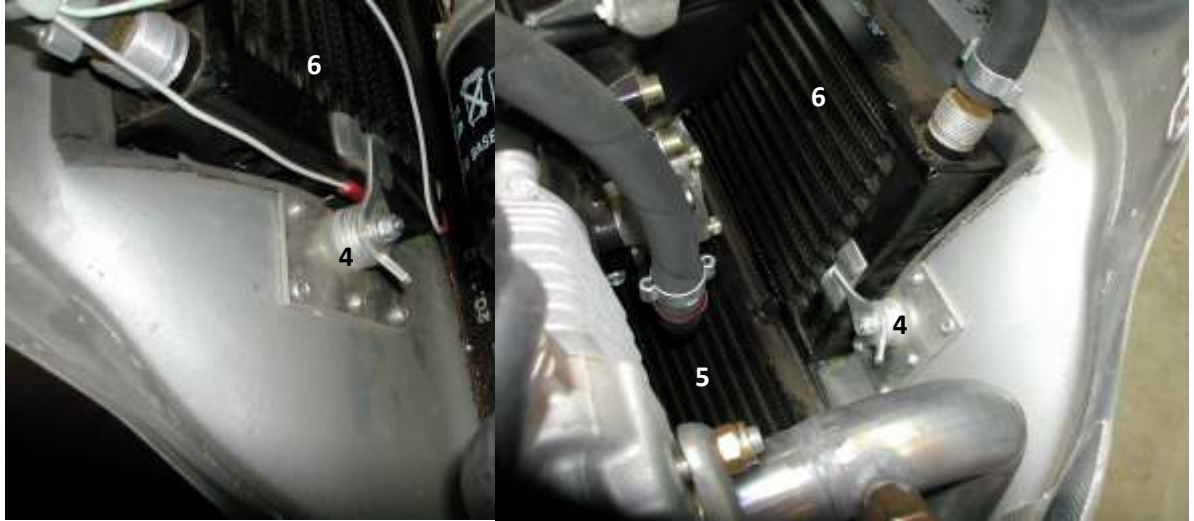

5. Support the cowl and remove the six Dzus fasteners located around the firewall and on the bracket behind the nose wheel strut.
6. Carefully move the cowl free from the aircraft.

## **PROCEDURE (INSTALLATION)**

### **BOTTOM COWL:**

1. Reverse the above procedure (removal) to install the bottom cowl, paying close attention to the following:
  - Ensure that the four catches (next to the radiators) are properly latched.
  - Tighten the clamp securing the air filter inlet pipe to the cowl air inlet sufficiently, but do not over tighten, as this may damage the cowl fibreglass inlet.

### **TOP COWL:**

1. Fit the bottom cowl.
2. Reverse the above procedure (removal) to install the top cowl. Ensure that the radiators and filter air supply pipe are properly connected before closing up the engine compartment.

## 5.2 ENGINE

The aircraft is fitted with one of the following engines:

1. Rotax 914 UL turbocharged engine (Sling 2). Refer to paragraph 1.3.
2. Rotax 912 ULS engine (Sling 2, Sling LSA). Refer to paragraph 1.3.
3. Rotax 912 iS fuel injected engine (Sling 2, Sling LSA). Refer to paragraph 1.3.

Refer to the latest revision of the Rotax 912 ULS / 912 iS / 914 UL operator's and maintenance manuals for an in-depth description of the engine and extensive specifications and technical data.

### 5.2.1 GENERAL MAINTENANCE AND SERVICING

Refer to and comply with the latest revision of the Rotax 912 ULS / 912 iS / 914 UL engine operator's manual and / or maintenance manuals, as applicable, for procedures and instructions.

### 5.2.2 CARBURETTOR SYNCHRONISATION (914 UL AND 912 ULS)

With the exception of idle speed synchronisation, no other carburettor adjustment is required.

Refer to the carburettor synchronization procedure in the latest revision of the Rotax 912 ULS / 914 UL engine operator's and / or maintenance manuals, as applicable.

### 5.2.3 REPLACING ENGINE OIL

Refer to the latest revision of the Rotax 912 ULS / 912 iS / 914 UL engine operator's manual and / or maintenance manuals, as applicable, for the procedures and instructions with regard to changing the engine oil.

### 5.2.4 REPLACING ENGINE COOLANT

Refer to the latest revision of the Rotax 912 ULS / 912 iS / 914 UL engine operator's and / or maintenance manuals, as applicable, for the procedures and instructions with regard to changing the engine coolant.

### 5.2.5 SPARK PLUG REPLACEMENT

Refer to and comply with the latest revision of the Rotax 912 ULS / 912 iS / 914 UL engine operator and / or maintenance manuals, as applicable.

### 5.2.6 VERIFYING ENGINE OIL LEVEL

CONSUMABLE MATERIAL REQUIRED		
ITEM	QUANTITY	NOTES
1	Engine oil.	As needed.
If required. Refer to paragraph 1.4.		
The above list is not necessarily a complete list of all material needed. Refer to the Sling 2 construction manual.		
AUTHORISED PERSONNEL		
Any person performing maintenance of any kind on the aircraft or any component thereof must do so in accordance with national legislation. This is the responsibility of the aircraft owner and any person who is to perform any maintenance on the aircraft.		

**WARNING**  
**MASTER / IGNITION SWITCHES OFF.**

**WARNING**  
**ALLOW THE ENGINE AND APPLICABLE COMPONENTS TO COOL COMPLETELY BEFORE PERFORMING ANY WORK OR INSPECTION IN THE ENGINE COMPARTMENT. HOT ENGINE COMPONENTS CAN CAUSE SERIOUS BURNS AND CAN IGNITE SPILLED FLUID / VAPOUR.**

#### PROCEDURE

1. Before verifying the oil level, ensure that there is no residual oil in the crank case. Oil is pumped back to the oil reservoir by performing the following procedure:
  - Master switch / ignition switches OFF.
  - Remove the oil reservoir cap.
  - Rotate the propeller counter clockwise (viewing from front of aircraft) until a murmuring / gurgling sound is heard. This signifies that air is pumped and indicates that all the oil has been pumped back to the reservoir.
2. Verify the oil level. The oil should be between the MIN and MAX marks on the dipstick. Replenish as needed.
3. Replace the oil reservoir cap and ensure it fits securely.

**5.2.7 AIR FILTER REMOVAL, CLEANING AND REPLACEMENT (914 UL)**

TOOLS / EQUIPMENT REQUIRED		
ITEM	QUANTITY	NOTES
1	Flat screwdriver.	1
2	Locking pliers.	1
The above list is not necessarily a complete list of all required tools and equipment needed. A calibrated torque wrench (with adequate range) and the correct size (as implied by the above tool list) accessories (sockets etc.) are implied for torquing bolts / nuts, if applicable. Refer to paragraph 1.5 for torque values.		
CONSUMABLE MATERIAL REQUIRED		
ITEM	QUANTITY	NOTES
1	Safety wire.	As needed.
2	Split pin.	1 Only if in need of replacement.
The above list is not necessarily a complete list of all material needed. Refer to the Sling 2 construction manual.		
AUTHORISED PERSONNEL		
Any person performing maintenance of any kind on the aircraft or any component thereof must do so in accordance with national legislation. This is the responsibility of the aircraft owner and any person who is to perform any maintenance on the aircraft.		

**WARNING**  
**MASTER / IGNITION SWITCHES OFF.**

**WARNING**

**ALLOW THE ENGINE AND APPLICABLE COMPONENTS TO COOL COMPLETELY BEFORE PERFORMING ANY WORK OR INSPECTION IN THE ENGINE COMPARTMENT. HOT ENGINE COMPONENTS CAN CAUSE SERIOUS BURNS AND CAN IGNITE SPILLED FLUID / VAPOUR.**

## PROCEDURE (REMOVAL)

Retain the clamps for reassembly.

1. Remove the safety wire (1) safety'ing the air filter housing (2) to the air intake manifold / turbocharger impeller (compressor) intake pipe clamp (3).
2. Loosen the clamp (4) securing the air filter to the air intake manifold / turbocharger (5) opening.
3. Loosen the clamp securing the air filter housing to the air intake pipe from the cowling, if required. Remove the air filter housing / air filter and push the air filter out of the housing.



4. If the air filter is to be removed from the engine for an extended period of time, blank off (6) the air intake manifold.

### PROCEDURE (CLEANING)

1. Wash the filter in a solution of lukewarm water and soap.
2. Rinse in clean water until all soap solution is washed away.
3. Leave the filter to dry out thoroughly.
4. Lightly spray with filter oil (refer to paragraph 1.4). Do not overspray.

#### CAUTION

**NEVER USE STEAM, CAUSTIC LIQUIDS, GASOLINE, STRONG DETERGENTS, PARTICLE REMOVING AGENTS OR COMPRESSED AIR TO CLEAN THE FILTER.**

**NEVER ATTEMPT TO DRY THE FILTER WITH A HEAT SOURCE (E.G. HEAT GUN) OR COMPRESSED AIR.**

### PROCEDURE (INSTALLATION)

1. Reverse the above procedure (removal) to install the air filter, paying close attention to the following:
  - Inspect the clamps for damage, cracks, corrosion and cleanliness. Replace if necessary.
  - Ensure that the filter enclosure is clean and dry on the inside.
  - Ensure that the seating area (for the air filter enclosure) on the air intake manifold is dry and clean. Ensure that the air filter enclosure coupling (to the air intake manifold) is clean and dry.
  - Inspect the air filter enclosure for damage or cracks. Replace if necessary.
  - Use safety wire to secure the filter housing to the air intake manifold pipe clamp.
2. Before flight, start the engine and verify for correct operation, stop the engine and inspect the air filter housing / air filter for security of attachment.

**5.2.8 AIR FILTER REMOVAL, CLEANING AND REPLACEMENT (912 IS)**

TOOLS / EQUIPMENT REQUIRED		
ITEM	QUANTITY	NOTES
1	Flat screwdriver.	1
<p>The above list is not necessarily a complete list of all required tools and equipment needed. A calibrated torque wrench (with adequate range) and the correct size (as implied by the above tool list) accessories (sockets etc.) are implied for torquing bolts / nuts, if applicable. Refer to paragraph 1.5 for torque values.</p>		
AUTHORISED PERSONNEL		
<p>Any person performing maintenance of any kind on the aircraft or any component thereof must do so in accordance with national legislation. This is the responsibility of the aircraft owner and any person who is to perform any maintenance on the aircraft.</p>		

**WARNING**  
**MASTER / IGNITION SWITCHES OFF.**

**WARNING**

**ALLOW THE ENGINE AND APPLICABLE COMPONENTS TO COOL COMPLETELY BEFORE PERFORMING ANY WORK OR INSPECTION IN THE ENGINE COMPARTMENT. HOT ENGINE COMPONENTS CAN CAUSE SERIOUS BURNS AND CAN IGNITE SPILLED FLUID / VAPOUR.**



### PROCEDURE (REMOVAL)

Retain the clamp for reassembly.

1. Loosen the clamp (1) securing the air filter housing (2) to the air intake manifold (3).
2. Remove / pull the air filter housing / air filter from the intake manifold / butterfly valve housing and remove the air filter from the filter housing.



3. If the air filter is to be removed from the engine for an extended period of time, blank off the air intake manifold.

### PROCEDURE (CLEANING)

Refer to the cleaning procedure in paragraph 5.2.7.

## PROCEDURE (INSTALLATION)

1. Reverse the above procedure (removal) to install the air filter, paying close attention to the following:
  - Inspect the clamp for damage, cracks, corrosion and cleanliness. Replace if necessary.
  - Ensure that the filter enclosure is clean and dry on the inside.
  - Ensure that the seating area (for the air filter enclosure) on the air intake manifold / butterfly valve housing is dry and clean. Ensure that the air filter enclosure coupling (to the air intake manifold / butterfly valve housing) is clean and dry.
  - Inspect the air filter enclosure for damage or cracks. Replace if necessary.

Before flight, start the engine and verify for correct operation, stop the engine and inspect the air filter housing / air filter for security of attachment.

**5.2.9 AIR FILTER REMOVAL, CLEANING AND REPLACEMENT (912 ULS)**

ITEM	QUANTITY	NOTES
1	Flat screwdriver.	1
<p>The above list is not necessarily a complete list of all required tools and equipment needed. A calibrated torque wrench (with adequate range) and the correct size (as implied by the above tool list) accessories (sockets etc.) are implied for torquing bolts / nuts, if applicable. Refer to paragraph 1.5 for torque values.</p>		
<p><b>AUTHORISED PERSONNEL</b></p>		
<p>Any person performing maintenance of any kind on the aircraft or any component thereof must do so in accordance with national legislation. This is the responsibility of the aircraft owner and any person who is to perform any maintenance on the aircraft.</p>		

**WARNING**  
**MASTER / IGNITION SWITCHES OFF.**

**WARNING**

**ALLOW THE ENGINE AND APPLICABLE COMPONENTS TO COOL COMPLETELY BEFORE PERFORMING ANY WORK OR INSPECTION IN THE ENGINE COMPARTMENT. HOT ENGINE COMPONENTS CAN CAUSE SERIOUS BURNS AND CAN IGNITE SPILLED FLUID / VAPOUR.**

### PROCEDURE (REMOVAL)

1. Remove the upper engine cowling (refer to paragraph 5.1.1).
2. Undo the latches (1) securing the air box cover / air pipe attachment (2) and slide the cover / air pipe attachment out.



3. Lift the air filter (3) out of the air box.

### PROCEDURE (CLEANING)

Refer to the cleaning procedure in paragraph 5.2.7.

### PROCEDURE (INSTALLATION)

1. Reverse the above procedure (removal) to install the air filter, paying close attention to the following:
  - Ensure that the filter enclosure / air box is clean and dry on the inside.
  - Inspect the air filter enclosure / air box and latches for damage or cracks. Replace if necessary.
2. Before flight, start the engine and verify for correct operation, stop the engine and inspect the air filter housing / air box for security of attachment.

**5.2.10 MUFFLER / HEAT EXCHANGER ASSEMBLY REMOVAL / REPLACEMENT (914 UL)**

TOOLS / EQUIPMENT REQUIRED		
ITEM	QUANTITY	NOTES
1	½ inch Spanner.	1
2	10 mm Spanner.	1
3	9 mm Spanner.	1
4	Flat screwdriver.	1
<p>The above list is not necessarily a complete list of all required tools and equipment needed. A calibrated torque wrench (with adequate range) and the correct size (as implied by the above tool list) accessories (sockets etc.) are implied for torquing bolts / nuts, if applicable. Refer to paragraph 1.5 for torque values.</p>		
AUTHORISED PERSONNEL		
<p>Any person performing maintenance of any kind on the aircraft or any component thereof must do so in accordance with national legislation. This is the responsibility of the aircraft owner and any person who is to perform any maintenance on the aircraft.</p>		

**WARNING**  
**MASTER / IGNITION SWITCHES OFF.**

**WARNING**

**ALLOW THE ENGINE AND APPLICABLE COMPONENTS TO COOL COMPLETELY BEFORE PERFORMING ANY WORK OR INSPECTION IN THE ENGINE COMPARTMENT. HOT ENGINE COMPONENTS CAN CAUSE SERIOUS BURNS AND CAN IGNITE SPILLED FLUID / VAPOUR.**

### PROCEDURE (REMOVAL)

Retain any bolts, clamps, spacers, screws and washers (with the exception of lock-washers) for reassembly.

1. Remove the engine cowling (refer to paragraph 5.1.1).
2. Loosen the clamp (1) retaining the air pipe (2) to the assembly shroud (3).



3. Loosen and remove the ring clamp (4) retaining the exhaust pipe to the engine mount. Undo and remove the bolts (5) retaining the assembly to the turbocharger. Loosen and remove the clamp (6) retaining the assembly to the mounting bracket (7).



4. Remove the assembly.

### PROCEDURE (INSTALLATION)

1. Reverse the above procedure (removal), paying close attention to the following:
  - Do not over tighten clamps.

**5.2.11 MUFFLER / HEAT EXCHANGER ASSEMBLY REMOVAL / REPLACEMENT (912 ULS / 912 IS)**

TOOLS / EQUIPMENT REQUIRED		
ITEM	QUANTITY	NOTES
1	10 mm Spanner.	1
2	9 mm Spanner.	1
3	Flat screwdriver.	1
<p>The above list is not necessarily a complete list of all required tools and equipment needed. A calibrated torque wrench (with adequate range) and the correct size (as implied by the above tool list) accessories (sockets etc.) are implied for torquing bolts / nuts, if applicable. Refer to paragraph 1.5 for torque values.</p>		
AUTHORISED PERSONNEL		
<p>Any person performing maintenance of any kind on the aircraft or any component thereof must do so in accordance with national legislation. This is the responsibility of the aircraft owner and any person who is to perform any maintenance on the aircraft.</p>		

**WARNING**  
**MASTER / IGNITION SWITCHES OFF.**

**WARNING**

**ALLOW THE ENGINE AND APPLICABLE COMPONENTS TO COOL COMPLETELY BEFORE PERFORMING ANY WORK OR INSPECTION IN THE ENGINE COMPARTMENT. HOT ENGINE COMPONENTS CAN CAUSE SERIOUS BURNS AND CAN IGNITE SPILLED FLUID / VAPOUR.**

## PROCEDURE (REMOVAL)

Retain any bolts, clamps, spacers, screws and washers (with the exception of lock-washers) for reassembly.

1. Remove the engine cowling (refer to paragraph 5.1.1).
2. Loosen the clamp (1) retaining the air pipe (2) to the assembly shroud (3). Loosen the clamps (4) retaining the muffler to the exhaust pipes / manifolds (from the cylinders).

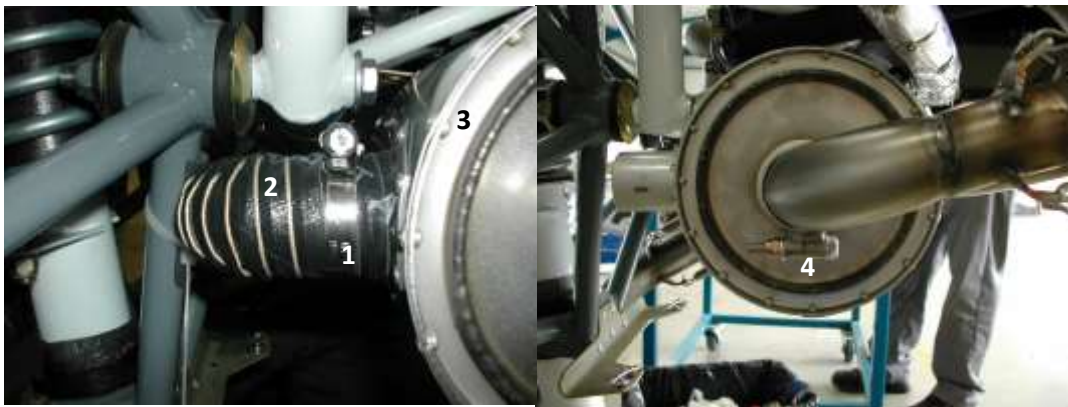

3. Loosen and remove the ring clamps (5) retaining the assembly to the mounting bracket and remove the assembly.

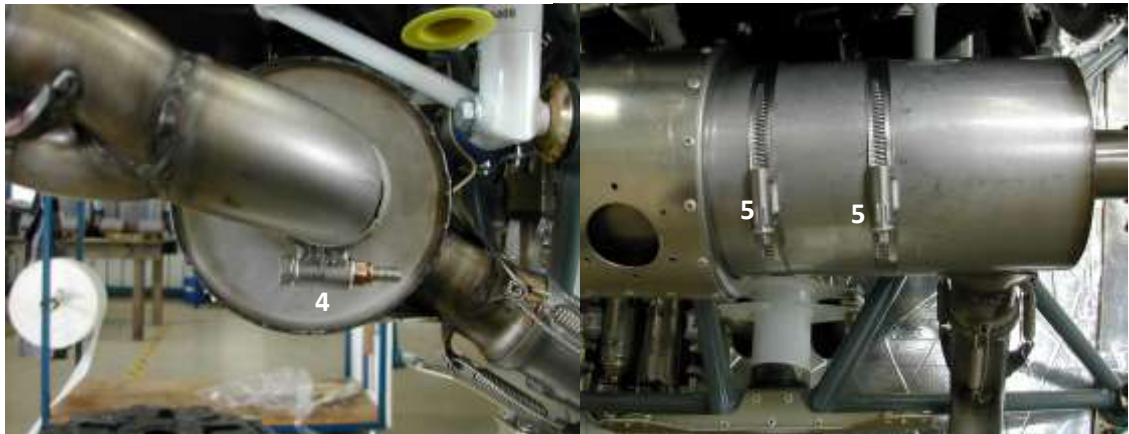

## PROCEDURE (INSTALLATION)

1. Reverse the above procedure (removal), paying close attention to the following:
  - Do not over tighten clamps.



**5.2.12 MUFFLER / HEAT EXCHANGER DISASSEMBLY / ASSEMBLY (914 UL)**

TOOLS / EQUIPMENT REQUIRED		
ITEM	QUANTITY	NOTES
1	3.2 mm Drill + drive (electric or hand drill).	1 Set
2	10 mm Spanner.	1
3	9 mm Spanner.	1
4	Blind-rivet tool.	1
The above list is not necessarily a complete list of all required tools and equipment needed. A calibrated torque wrench (with adequate range) and the correct size (as implied by the above tool list) accessories (sockets etc.) are implied for torquing bolts / nuts, if applicable. Refer to paragraph 1.5 for torque values.		
CONSUMABLE MATERIAL REQUIRED		
ITEM	QUANTITY	NOTES
1	Aluminium blind-rivets (3.2 mm)	As needed. For assembly.
The above list is not necessarily a complete list of all material needed. Refer to the Sling 2 construction manual.		
AUTHORISED PERSONNEL		
Any person performing maintenance of any kind on the aircraft or any component thereof must do so in accordance with national legislation. This is the responsibility of the aircraft owner and any person who is to perform any maintenance on the aircraft.		

### PROCEDURE (DISASSEMBLY)

Retain any bolts, nuts (except lock-nuts) spacers, screws and washers (with the exception of lock-washers) for reassembly.

1. Remove the heat exchanger / muffler assembly (refer to paragraph 5.2.10).
2. Drill out the line of rivets (1) clamping the shroud (2) plate together. Loosen the clamps (3) clamping the shroud to the muffler and slide the shroud off the muffler.

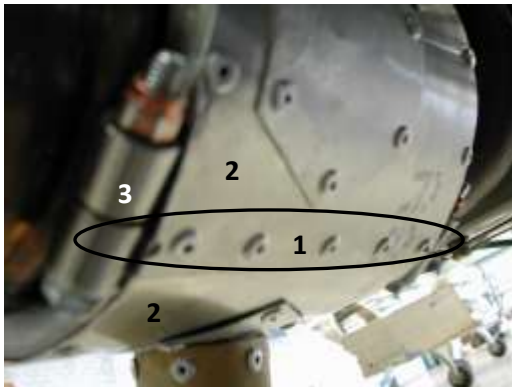

### PROCEDURE (ASSEMBLY)

1. Reverse the above procedure (removal), paying close attention to the following:
  - Do not over tighten the clamps.

**5.2.13 MUFFLER / HEAT EXCHANGER DISASSEMBLY / ASSEMBLY (912 ULS / 912 IS)**

TOOLS / EQUIPMENT REQUIRED		
ITEM	QUANTITY	NOTES
1	3.2 mm Drill + drive (electric or hand drill).	1 Set
2	Blind-rivet tool.	1
The above list is not necessarily a complete list of all required tools and equipment needed. A calibrated torque wrench (with adequate range) and the correct size (as implied by the above tool list) accessories (sockets etc.) are implied for torquing bolts / nuts, if applicable. Refer to paragraph 1.5 for torque values.		
CONSUMABLE MATERIAL REQUIRED		
ITEM	QUANTITY	NOTES
1	Aluminium blind-rivets (3.2 mm)	As needed. For assembly.
The above list is not necessarily a complete list of all material needed. Refer to the Sling 2 construction manual.		
AUTHORISED PERSONNEL		
Any person performing maintenance of any kind on the aircraft or any component thereof must do so in accordance with national legislation. This is the responsibility of the aircraft owner and any person who is to perform any maintenance on the aircraft.		

### PROCEDURE (DISASSEMBLY)

Retain any bolts, nuts (except lock-nuts) spacers, screws and washers (with the exception of lock-washers) for reassembly.

1. Remove the heat exchanger / muffler assembly (refer to paragraph 5.2.11).
2. Drill out the rivets (1) clamping the shroud (2) plate together and retaining the shroud to the muffler. Slide the shroud off the muffler.

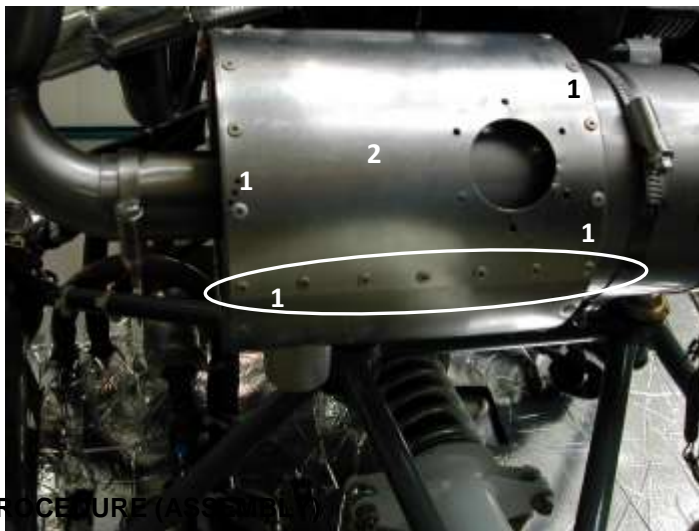

### PROCEDURE (ASSEMBLY)

1. Reverse the above procedure (removal).

### 5.2.14 REMOVAL / INSTALLATION OF OIL AND COOLANT RADIATORS

TOOLS / EQUIPMENT REQUIRED			
ITEM		QUANTITY	NOTES
1	5/16 Spanner.	1	
2	3 mm Allen key.	1	
The above list is not necessarily a complete list of all required tools and equipment needed. A calibrated torque wrench (with adequate range) and the correct size (as implied by the above tool list) accessories (sockets etc.) are implied for torquing bolts / nuts, if applicable. Refer to paragraph 1.5 for torque values.			
AUTHORISED PERSONNEL			
Any person performing maintenance of any kind on the aircraft or any component thereof must do so in accordance with national legislation. This is the responsibility of the aircraft owner and any person who is to perform any maintenance on the aircraft.			

#### PROCEDURE

1. The radiators (1) are physically separated / attached from / to the bottom cowling (2) by undoing / fastening the clamps (3) securing them to the cowl. For radiator pipe disconnection / connection refer to paragraphs 5.2.15 and 5.2.16.

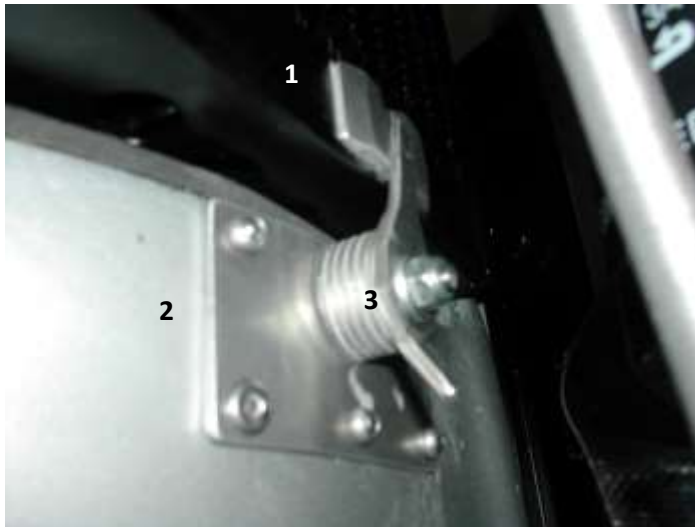

2. After installation inspect for security of attachment.

**5.2.15 OIL COOLER / RADIATOR PIPE CONNECTION / DISCONNECTION**

TOOLS / EQUIPMENT REQUIRED			
ITEM	QUANTITY	NOTES	
1	16 mm Spanner.	1	
2	Shifting spanner.	1	
3	Front pincer pliers.	1	To crimp two-ear pipe clamps. Connection.
4	Hacksaw or Dremel tool.	1	Refer to paragraph 5.1. Disconnection.
The above list is not necessarily a complete list of all required tools and equipment needed. A calibrated torque wrench (with adequate range) and the correct size (as implied by the above tool list) accessories (sockets etc.) are implied for torqueing bolts / nuts, if applicable. Refer to paragraph 1.5 for torque values.			
CONSUMABLE MATERIAL REQUIRED			
ITEM	QUANTITY	NOTES	
1	Loctite 577.	As needed.	Oil cooler fittings.
2	Two-ear clamps (20 mm).	2	
The above list is not necessarily a complete list of all material needed. Refer to the Sling 2 construction manual.			
AUTHORISED PERSONNEL			
Any person performing maintenance of any kind on the aircraft or any component thereof must do so in accordance with national legislation. This is the responsibility of the aircraft owner and any person who is to perform any maintenance on the aircraft.			

**WARNING**  
**SPILLED OIL CREATES A SAFETY HAZARD. CLEAN UP SPILLED OIL BEFORE CONTINUING WITH WORK.**

## PROCEDURE (CONNECTION)

1. Apply thread locking sealant to the threads of couplings (1) and (2) and fit into the radiator (3).



2. Slip a two-ear clamp (4) over each pipe (5), slip the pipes over the couplings (2) and move the two-ear clamps into position.

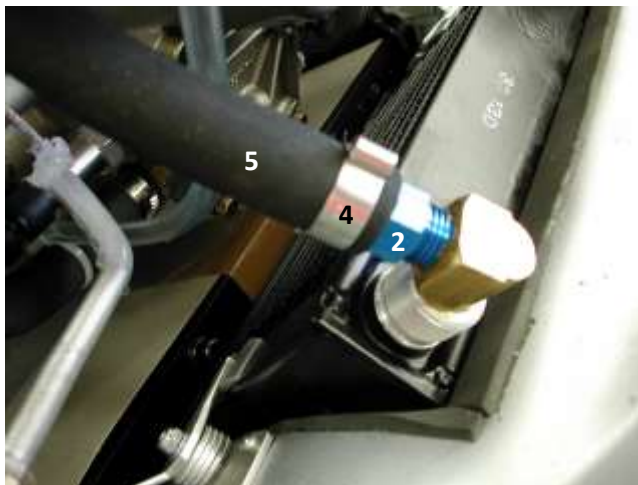

3. Crimp the two ear plugs.
4. Inspect for security of attachment and correct sense of connection (i.e. the correct pipe to the correct oil cooler port).

### PROCEDURE (DISCONNECTION)

1. Drain any fluids as required.
2. Remove the two-ear clamps (refer to paragraph 5.1) and pull the pipes from the fittings.
3. Blank off oil pipes if to be unconnected for a substantial period of time, to prevent drip and entry of foreign material.
4. Unscrew the fittings from the radiator, if required.



**5.2.16 COOLANT RADIATOR PIPE CONNECTION / DISCONNECTION**

TOOLS / EQUIPMENT REQUIRED			
ITEM		QUANTITY	NOTES
1	Flat screwdriver.	1	
2	Side cutter.	1	Removal
3	Locking pliers.	1	Installation
<p>The above list is not necessarily a complete list of all required tools and equipment needed. A calibrated torque wrench (with adequate range) and the correct size (as implied by the above tool list) accessories (sockets etc.) are implied for torquing bolts / nuts, if applicable. Refer to paragraph 1.5 for torque values.</p>			
CONSUMABLE MATERIAL REQUIRED			
ITEM		QUANTITY	NOTES
1	Safety wire.	As needed.	
<p>The above list is not necessarily a complete list of all material needed. Refer to the Sling 2 construction manual.</p>			
AUTHORISED PERSONNEL			
<p>Any person performing maintenance of any kind on the aircraft or any component thereof must do so in accordance with national legislation. This is the responsibility of the aircraft owner and any person who is to perform any maintenance on the aircraft.</p>			

**WARNING**

**SPILLED COOLANT CREATES A SAFETY HAZARD. CLEAN UP SPILLED COOLANT BEFORE CONTINUING WITH WORK.**

#### PROCEDURE (CONNECTION)

1. Slip a hose clamp over each pipe before connection Push the pipe(s) over the radiator connection(s).
2. Move the hose clamp(s) into place and tighten. Do not over tighten, as this may damage the pipes.
3. Use safety wire and secure the insulation blanket(s) around the pipe(s).
4. Inspect for security of attachment.

#### PROCEDURE (DISCONNECTION)

1. Remove the safety wire securing the insulation blanket to the pipe, fold the blanket back to expose the hose clamp and loosen the clamp.
2. Pull the pipe of the radiator connection.
3. Blank off coolant pipes if to be unconnected for a substantial period of time, to prevent drip and entry of foreign material.

### 5.2.17 ENGINE REMOVAL / INSTALLATION (914 UL)

TOOLS / EQUIPMENT REQUIRED			
ITEM		QUANTITY	NOTES
1	17 mm Spanner, 16 mm Spanner.	1 Each	
2	Support stand for aircraft tail.	1	
3	<u>Calibrated</u> torque wrench, with range of at least 40 to 45 Nm.	1	Installation only.
4	10 mm Spanner, 9 mm spanner.	1 Each	
5	17 mm Socket.	1	To fit item 3.
6	Side cutter.	1	
7	Locking pliers.	1	Installation only.
8	22 mm Spanner and 14 mm spanner (914 UL only).	1 Each	If oil reservoir not removed with / attached to engine.
9	½ inch Socket and spanner.	1 Each	If engine mount to be removed from firewall.

The above list is not necessarily a complete list of all required tools and equipment needed. A calibrated torque wrench (with adequate range) and the correct size (as implied by the above tool list) accessories (sockets etc.) are implied for torquing bolts / nuts, if applicable. Refer to paragraph 1.5 for torque values.

CONSUMABLE MATERIAL REQUIRED			
ITEM		QUANTITY	NOTES
1	Orange paint.	1	
2	Safety wire, Loctite 577.	As / if needed.	Loctite 577 for oil pipe fitting (to oil reservoir) threads.

The above list is not necessarily a complete list of all material needed. Refer to the Sling 2 construction manual.

AUTHORISED PERSONNEL			
Any person performing maintenance of any kind on the aircraft or any component thereof must do so in accordance with national legislation. This is the responsibility of the aircraft owner and any person who is to perform any maintenance on the aircraft.			

**WARNING**  
**MASTER / IGNITION SWITCHES OFF.**

**WARNING**  
**ALLOW THE ENGINE AND APPLICABLE COMPONENTS TO COOL COMPLETELY BEFORE PERFORMING ANY WORK OR INSPECTION IN THE ENGINE COMPARTMENT. HOT ENGINE COMPONENTS CAN CAUSE SERIOUS BURNS AND CAN IGNITE SPILLED FLUID / VAPOUR.**

## PROCEDURE (REMOVAL)

The procedures described below are general. Reference must be made to the applicable equipment / system documentation with regard to the connection and disconnection of mechanical cables, electrical wires, signal wires and fluid piping. The following documents have relevance:

- Rotax 914 UL installation manual, maintenance manuals and operator's manual.
- AP3 series and AP4 series constant speed propeller operator's manual.
- MGL RDAC and EFIS documentation.

Retain any bolts, clamps, spacers, screws and washers (with the exception of lock-washers) for reassembly.

1. Support the tail of the aircraft adequately before removing the engine.
2. Remove the propeller (refer to paragraph 5.3.5, 5.3.6 or 5.3.7, as applicable) if the intention is to remove the engine without the propeller attached.
3. Remove the top and bottom cowls (refer to paragraph 5.1.1).
4. Undo the clamps (1) retaining the oil reservoir to the firewall bracket. Removing the oil reservoir with the engine (i.e. not disconnecting the piping) has the advantage that the oil system remains closed and negates the need for refilling. Alternatively the piping (2) to the oil reservoir can be disconnected, leaving the oil reservoir behind on the firewall.



5. Cut the tie wraps (3) retaining the coolant overflow bottle to the firewall. Removing the overflow bottle with the engine has the advantage that the cooling system remains closed. Alternatively remove the pipe (4) from the bottle.



6. Disconnect the fuel supply pipe (between the fuel pump assembly and the engine) either at the fuel pump assembly side or at the engine side. Blank off to prevent drip and / or spillage.
7. Disconnect the fuel return line from the engine. Blank off to prevent drip and / or spillage.
8. Disconnect the throttle cables from the carburetors.
9. Disconnect the choke cables from the carburetors.
10. Disconnect the positive (red) cable between the starter solenoid and the starter, Disconnect the ground (black) cable between the battery and starter.
11. Disconnect the ring clamp (5) retaining the exhaust to the engine mount.



12. Disconnect all sensor / transducer wires between the engine and RDAC unit, either at the engine side or at the RDAC side. Disconnect the propeller controller signal wires (Airmaster propeller).
13. Disconnect the electrical wiring between the turbocharger control unit (TCU) and the engine.

14. Disconnect the two plugs (6) between the TCU and the waste gate servo (7). This allows the servo to be removed with the engine (by undoing the two bolts (8) retaining it to the firewall), keeping the servo-to-waste gate cable connection in place (and negating the need to re-adjust the cable after reconnection). Alternatively disconnect the cable (9) from the servo at the turbocharger (10) and leave the servo attached to the firewall when removing the engine.



15. Disconnect the cabin air feed pipe (11) at the heat exchanger / muffler assembly by undoing the clamp.



16. Cut any / all tie wraps securing pipes (connected to the engine) and electrical cabling (connected to the engine) to the engine mount and which would prevent the engine and attached piping / cabling from pulling free of the engine mount.
17. Support the engine in such a manner that when the bolts attaching the engine suspension frame to the engine mount are undone they can be removed / pulled out freely. If the engine is supported by hoisting it with a crane or block and tackle, attachment must be such that the hoisted assembly (engine, engine with propeller attached, etc.) balances evenly (about its centre of gravity) under the hoist when freed and moved away from the engine mount.

18. With the engine securely and adequately supported, undo the four bolts (12) and nuts retaining the engine suspension frame (13) to the engine mount (14). Remove the bolts.

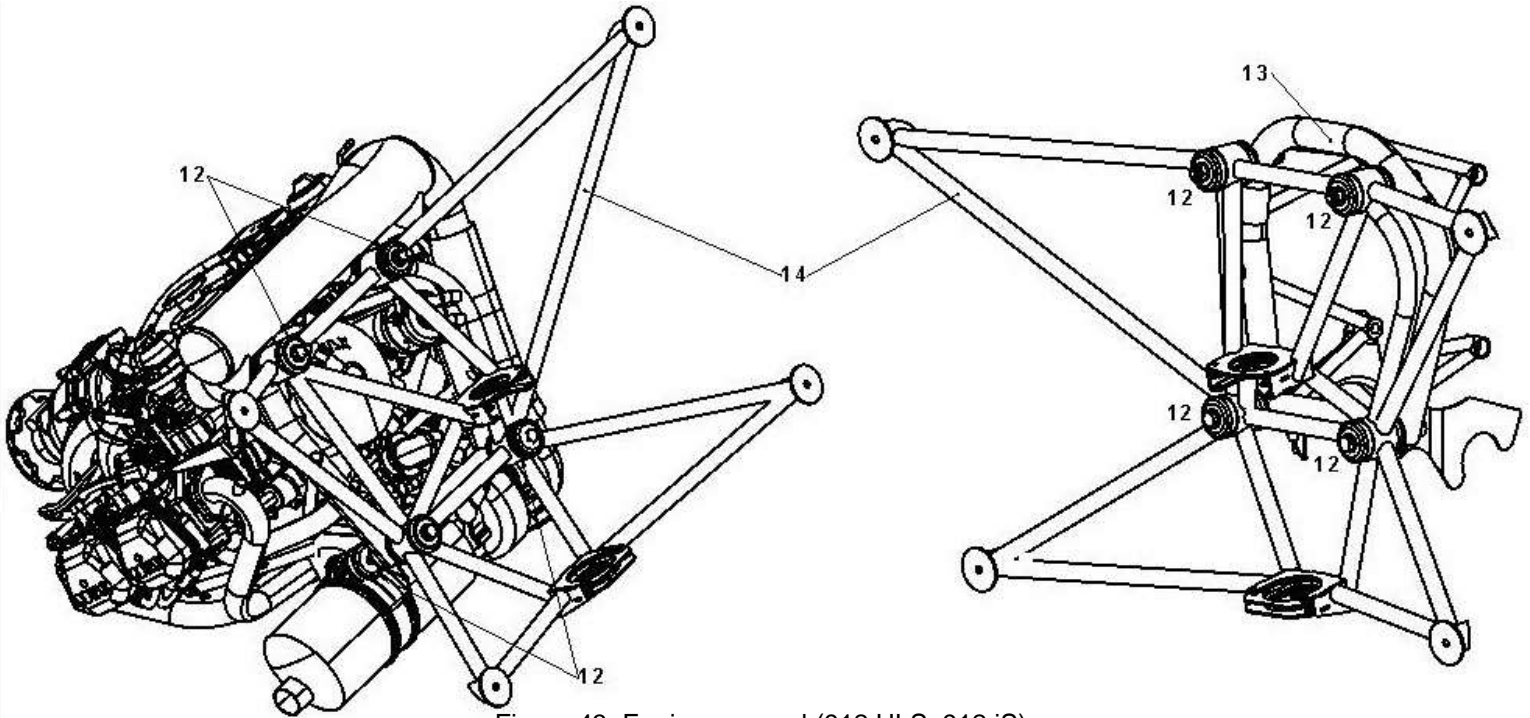

Figure 43: Engine removal (912 ULS, 912 iS).

19. Carefully move the engine free from the engine mount.
20. Alternatively (to separating the engine suspension frame from the engine mount) the engine can also be removed (as a unit with the nose gear) by undoing the four bolts retaining the engine mount to the firewall. In that case the pushrods from the rudder pedals to the nose gear must be disconnected first and the aircraft must be supported adequately in preparation of the absence of the nose gear. In this case the exhaust need not be disconnected from the engine mount (step 11 above) and piping and cables secured to the engine mount need not be freed (step 16 above).

### PROCEDURE (INSTALLATION)

The procedures below are general. Reference must be made to the applicable equipment / system documentation with regard to the connection and disconnection of electrical wires, signal wires and fluid piping. The following documents have relevance:

- Rotax 914 UL installation manual, maintenance manuals and operator's manual.
- AP3 series and AP4 series constant speed propeller operator's manual.
- MGL RDAC and EFIS documentation.

1. Reverse the above procedure (removal), paying close attention to the following:
  - Inspect all bolts, nuts and screws for damage. Replace if necessary.
  - Do not reuse lock-nuts. Fit new.
  - Do not over tighten clamps.
  - Apply thread locking sealant to the oil reservoir pipe fittings (if removed).
  - Note that the two top mounting bolts are installed with the bolt heads facing forward. The bottom bolts are installed with the bolt heads facing backward. Observe correct placement of washers, spacers / bushes and vibration dampers (refer to Figure 44). Note that the two bottom lock-nuts seat directly on the turbocharger and exhaust muffler brackets, without washers.

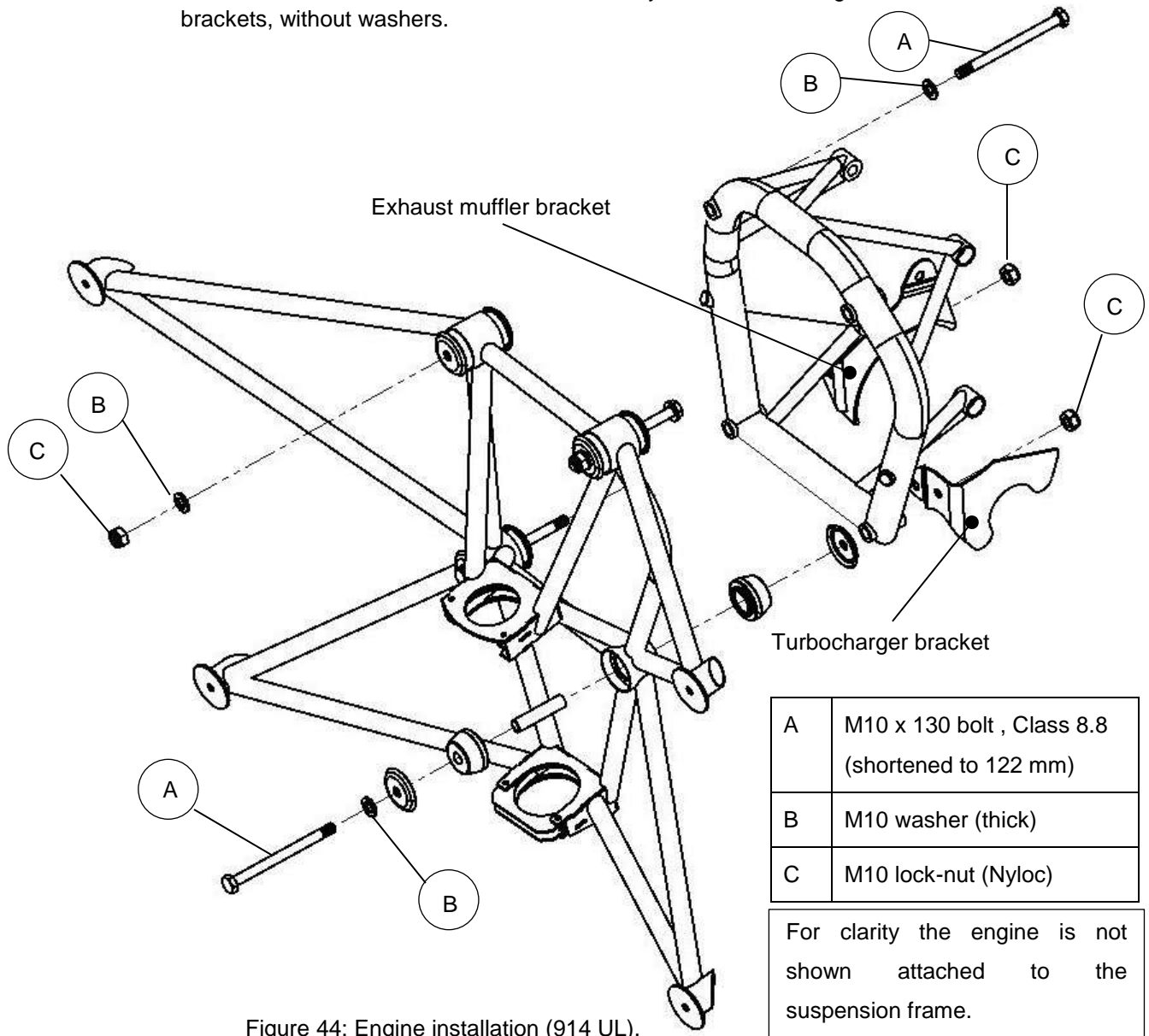

Figure 44: Engine installation (914 UL).



2. Inspect the rubber vibration dampers for damage before fitment. Replace if necessary.
3. Place a drop of oil (engine oil) on the threads before fitment and torque the four bolts and nuts retaining the engine suspension frame to the engine mount to the recommended value (refer to paragraph 1.5.2). Torque in increments by alternately tightening opposite pairs of bolts / nuts.
4. Torque the four bolts and nuts retaining the engine mount to the firewall (if that option was followed) to the recommended value (refer to paragraph 1.5.2). Torque in increments by alternately tightening opposite pairs of bolts / nuts.
5. Inspect for correct connection of electrical wiring.
6. Inspect for adequate operating fluid levels in engine. Replenish if necessary.
7. Inspect all cables, electrical wiring and piping for security of attachment.
8. If the waste gate servo cable was disconnected at the turbocharger it needs to be re-adjusted after the servo cycles after initial start-up, Refer to the latest revision of the Rotax 914 UL maintenance manual.
9. Before flight, an adequate ground run must be performed. Ensure sufficient engine fluid levels before starting the engine. Follow the preparations for trial run of the engine as set out in the latest revision of the Rotax 914 installation manual. During the run monitor all engine indications for correctness. Test / monitor all systems which were disconnected during the removal of the engine (e.g. the propeller / propeller controller (Airmaster propeller), the RDAC / EFIS) as far as possible on the ground.
10. After the ground run inspect for leaks (fluid pipes) and security of attachment (bolts, connectors, cables, pipes etc.).

**5.2.18 ENGINE REMOVAL / INSTALLATION (912 ULS / 912 IS)**

TOOLS / EQUIPMENT REQUIRED			
ITEM		QUANTITY	NOTES
1	17 mm Spanner, 16 mm Spanner.	1 Each	
2	Support stand for aircraft tail.	1	
3	<u>Calibrated</u> torque wrench, with range of at least 40 to 45 Nm.	1	Installation only.
4	17 mm Socket.	1	To fit item 3.
5	Side cutter.	1	
6	Locking pliers.	1	Installation only.
7	22 mm Spanner (912 ULS) or adjustable spanner / wrench (912 IS, 912 ULS).	1	If oil reservoir not removed with / attached to engine.
8	½ inch Socket (with drive) and spanner.	1 Each	If engine mount to be removed from firewall.

The above list is not necessarily a complete list of all required tools and equipment needed. A calibrated torque wrench (with adequate range) and the correct size (as implied by the above tool list) accessories (sockets etc.) are implied for torquing bolts / nuts, if applicable. Refer to paragraph 1.5 for torque values.

CONSUMABLE MATERIAL REQUIRED			
ITEM		QUANTITY	NOTES
1	Orange paint.	1	
2	Safety wire, Loctite 577, tie wraps.	As / if needed.	Loctite 577 for oil pipe fitting (to oil reservoir) threads.

The above list is not necessarily a complete list of all material needed. Refer to the Sling 2 construction manual.

AUTHORISED PERSONNEL			
Any person performing maintenance of any kind on the aircraft or any component thereof must do so in accordance with national legislation. This is the responsibility of the aircraft owner and any person who is to perform any maintenance on the aircraft.			

**WARNING**  
**MASTER / IGNITION SWITCHES OFF.**

**WARNING**  
**ALLOW THE ENGINE AND APPLICABLE COMPONENTS TO COOL COMPLETELY BEFORE PERFORMING ANY WORK OR INSPECTION IN THE ENGINE COMPARTMENT. HOT ENGINE COMPONENTS CAN CAUSE SERIOUS BURNS AND CAN IGNITE SPILLED FLUID / VAPOUR.**

## PROCEDURE (REMOVAL)

The procedures described below are general. Reference must be made to the applicable equipment / system documentation with regard to the connection and disconnection of mechanical cables, electrical wires, signal wires and fluid piping. The following documents have relevance:

- Rotax 912 ULS / 912 iS installation manual, maintenance manuals and operator's manual.
- Propeller operator's manual / installation and operation manual / manufacturer documentation.
- MGL RDAC and EFIS documentation.

Retain any bolts, clamps, spacers, screws and washers (with the exception of lock-washers) for reassembly.

1. Support the tail of the aircraft adequately before removing the engine.
2. Remove the propeller (refer to paragraph 5.3.5, 5.3.6 or 5.3.7, as applicable) if the intention is to remove the engine without the propeller attached.
3. Remove the top and bottom cowls (refer to paragraph 5.1.1).
4. Undo the clamps (1) retaining the oil reservoir to the firewall bracket. Removing the oil reservoir with the engine (i.e. not disconnecting the piping) has the advantage that the oil system remains closed and negates the need for refilling. Alternatively the piping (2) to the oil reservoir can be disconnected, leaving the oil reservoir behind on the firewall.

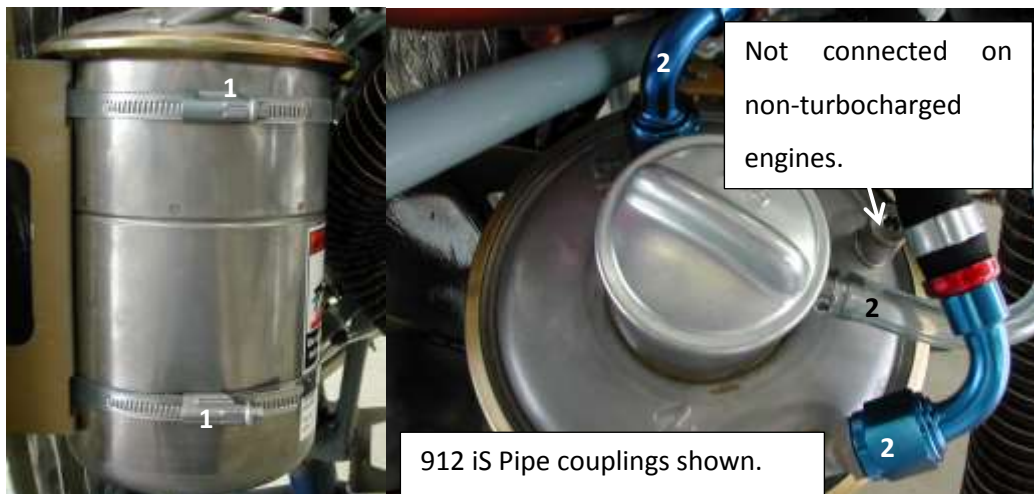

5. Cut the tie wraps (3) retaining the coolant overflow bottle to the firewall. Removing the overflow bottle with the engine has the advantage that the cooling system remains closed. Alternatively remove the pipe (4) from the bottle.



6. Disconnect the fuel supply pipe(s) either at the fuel pump assembly side (912 iS) / electric fuel pump side (912 UL) or at the engine side. Blank off to prevent drip and / or spillage.
7. Disconnect the fuel return line from the engine. Blank off to prevent drip and / or spillage.
8. Disconnect the throttle cables from the carburetors (912 ULS). Disconnect the throttle cables from the air intake manifold / butterfly valve housing (912 iS).
9. Disconnect the choke cables from the carburetors (912 ULS).
10. Disconnect the positive (red) cable between the starter solenoid and the starter, Disconnect the ground (black) cable between the battery and starter.
11. Disconnect all sensor / transducer wires between the engine and RDAC unit and fuse box (912 iS) either at the engine side or at the RDAC / fuse box side. Disconnect the propeller controller signal wires (Airmaster propeller).
12. Disconnect the cabin air feed pipe (5) at the heat exchanger / muffler assembly by undoing the clamp (or at the firewall).



13. Cut any / all tie wraps securing pipes (connected to the engine) and electrical cabling (connected to the engine) to the engine mount and which would prevent the engine and attached piping / cabling from pulling free of the engine mount.
14. Support the engine in such a manner that when the bolts attaching the engine suspension frame to the engine mount are undone they can be removed / pulled out freely. If the engine is supported by hoisting it with a crane or block and tackle, attachment must be such that the hoisted assembly (engine, engine with propeller attached, etc.) balances evenly (about its centre of gravity) under the hoist when freed and moved away from the engine mount.
15. With the engine securely and adequately supported, undo the four bolts (6) and nuts retaining the engine suspension frame (7) to the engine mount (8). Remove the bolts.

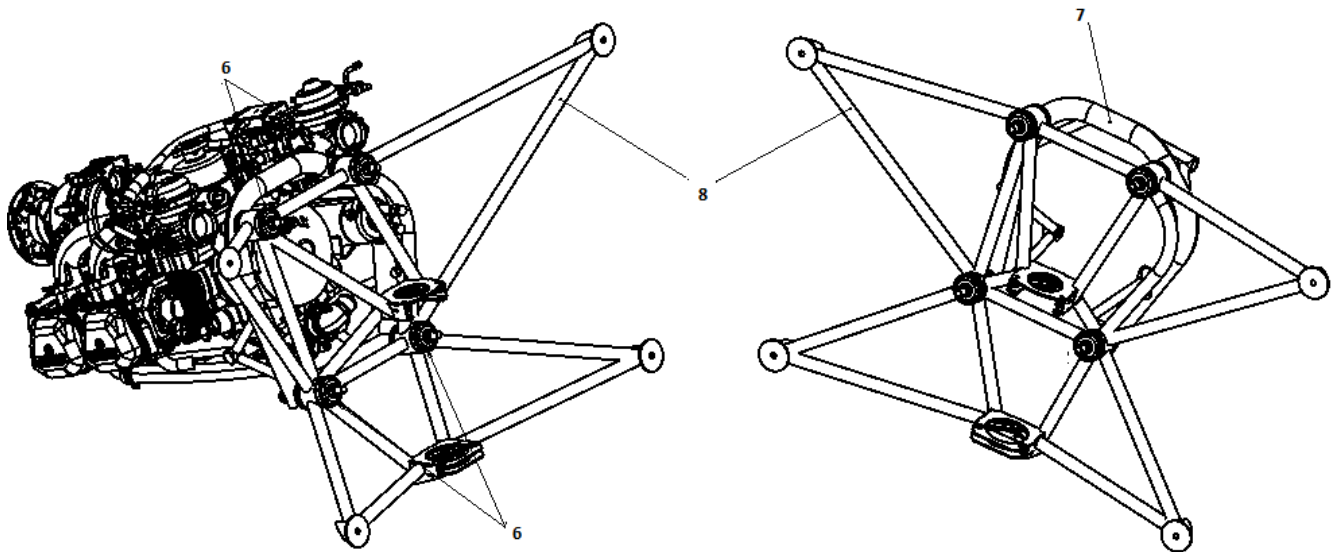

Figure 45: Engine removal (912 ULS, 912 iS).

16. Carefully move the engine free from the engine mount.
17. Alternatively (to separating the engine suspension frame from the engine mount) the engine can also be removed (as a unit with the nose gear) by undoing the four bolts retaining the engine mount to the firewall. In that case the pushrods from the rudder pedals to the nose gear must be disconnected first and the aircraft must be supported adequately in preparation of the absence of the nose gear. In this case the piping and cables secured to the engine mount need not be freed (step 13 above).

## PROCEDURE (INSTALLATION)

The procedures below are general. Reference must be made to the applicable equipment / system documentation with regard to the connection and disconnection of electrical wires, signal wires and fluid piping. The following documents have relevance:

- Rotax 912 ULS / 912 iS installation manual, maintenance manuals and operator's manual.
  - Propeller operator's manual / installation and operation manual / manufacturer documentation.
  - MGL RDAC and EFIS documentation.
11. Reverse the above procedure (removal), paying close attention to the following:
- Inspect all bolts, nuts and screws for damage. Replace if necessary.
  - Do not reuse lock-nuts. Fit new.
  - Do not over tighten clamps.
  - Apply thread locking sealant to the oil reservoir pipe fittings (if removed).
  - Note that all the mounting bolts are installed with the bolt heads facing forward. Observe correct placement of washers, spacers / bushes and vibration dampers (refer to Figure 46).

A	M10 x 130 bolt, Class 8.8 (shortened to 122 mm)
B	M10 washer (thick)
C	M10 lock nut (Nyloc)

For clarity the engine is not shown attached to the suspension frame.

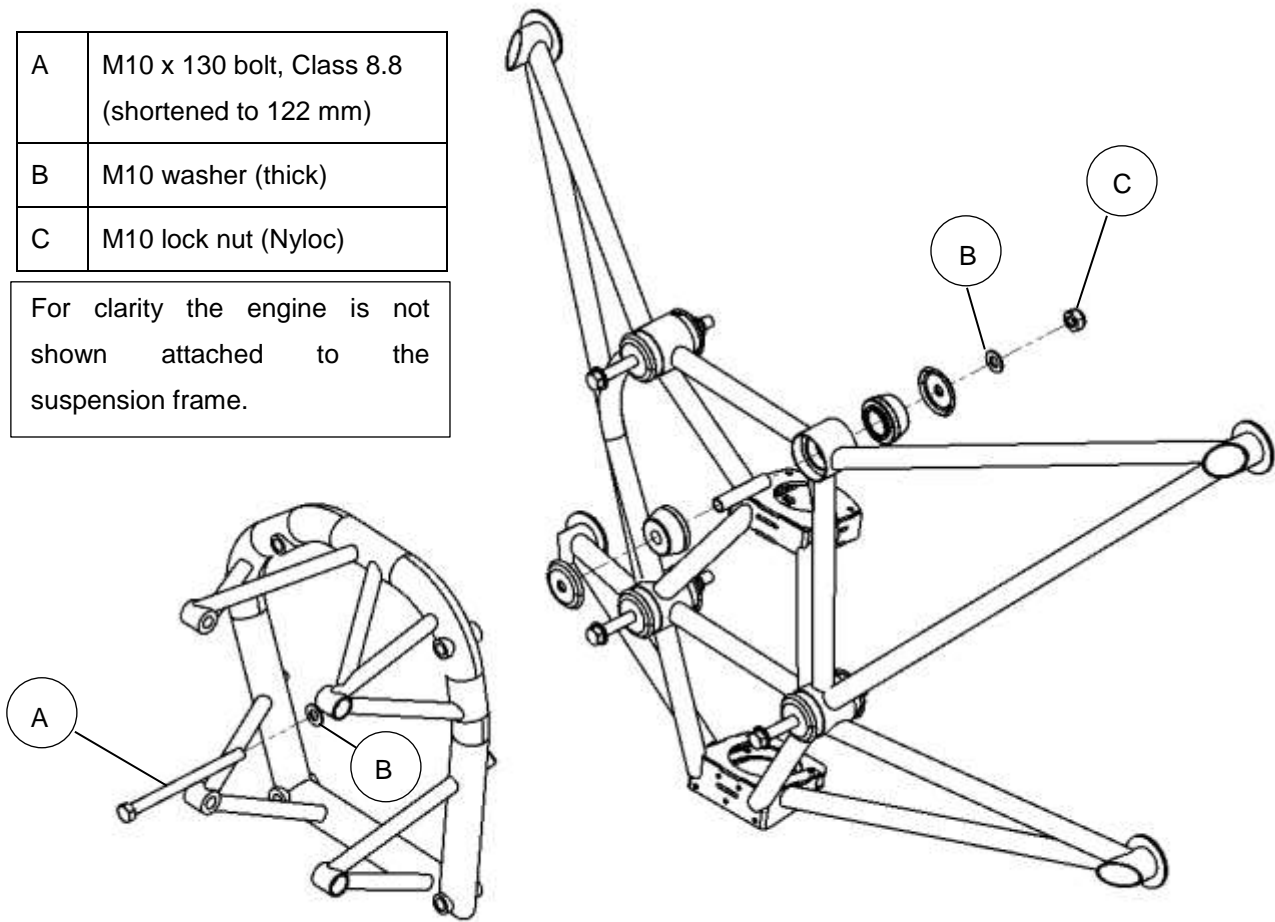

Figure 46: Engine installation (912 ULS, 912 iS)

12. Inspect the rubber vibration dampers for damage before fitment. Replace if necessary.
13. Place a drop of oil (engine oil) on the threads before fitment and torque the four bolts and nuts retaining the engine suspension frame to the engine mount to the recommended value (refer to paragraph 1.5.2). Torque in increments by alternately tightening opposite pairs of bolts / nuts.
14. Torque the four bolts and nuts retaining the engine mount to the firewall (if that option was followed) to the recommended value (refer to paragraph 1.5.2). Torque in increments by alternately tightening opposite pairs of bolts / nuts.
15. Inspect for correct connection of electrical wiring.
16. Inspect for adequate operating fluid levels in engine. Replenish if necessary.
17. Inspect all cables, electrical wiring and piping for security of attachment.

18. Before flight, an adequate ground run must be performed. Ensure sufficient engine fluid levels before starting the engine. Follow the preparations for trial run of the engine as set out in the latest revision of the engine installation and operators manuals (912 ULS) or refer to paragraph 6. During the run monitor all engine indications for correctness. Test / monitor all systems which were disconnected during the removal of the engine (e.g. the propeller / propeller controller (Airmaster propeller), the RDAC / EFIS) as far as possible on the ground.
19. After the ground run inspect for leaks (fluid pipes) and security of attachment (bolts, connectors, cables, pipes etc.).



## 5.2.19 ENGINE CONTROL SYSTEM (THROTTLE AND CHOKE)

### 914 UL / 912 ULS ENGINE:

Each carburettor throttle control lever is attached to the throttle lever (in cabin) by a separate Bowden cable. Friction on the throttle lever (in cabin) is effected by two friction discs (refer to Figure 47 )

For attachment of the Bowden cable to the carburettor throttle control lever and adjustment refer to the latest revision / edition of the Rotax 914 UL / 912 ULS engine installation manual and maintenance manuals, as applicable.

Each carburettor choke control lever is attached to the choke knob (in the cabin) via a separate Bowden cable.

For attachment of the Bowden cable to the carburettor choke control lever and adjustment refer to the latest revision / edition of the Rotax 914 UL / 912 ULS engine installation manual and maintenance manuals, as applicable.

### 912 iS ENGINE:

The butterfly / throttle valve control lever is attached to the throttle lever (in cabin) by a Bowden cable. Friction on the throttle lever (in cabin) is effected by two friction discs (refer to Figure 47 ).

For attachment of the Bowden cable to the butterfly / throttle valve control lever and adjustment refer to the latest revision / edition of the Rotax 912 iS engine installation manual and maintenance manuals, as applicable.

### 5.2.19.1 THROTTLE LEVER FRICTION ADJUSTMENT

TOOLS / EQUIPMENT REQUIRED			
ITEM		QUANTITY	NOTES
1	3/8 Spanner	2	
2	2 mm Allen key, 2.5 mm Allen key	1 each	Inspection panel screws.
The above list is not necessarily a complete list of all required tools and equipment needed. A calibrated torque wrench (with adequate range) and the correct size (as implied by the above tool list) accessories (sockets etc.) are implied for torquing bolts / nuts, if applicable. Refer to paragraph 1.5 for torque values.			
CONSUMABLE MATERIAL REQUIRED			
ITEM		QUANTITY	NOTES
1	Split pin	1.	
2	Loctite 222	As needed	Centre console inspection panel.
The above list is not necessarily a complete list of all material needed. Refer to the Sling 2 construction manual.			
AUTHORISED PERSONNEL			
Any person performing maintenance of any kind on the aircraft or any component thereof must do so in accordance with national legislation. This is the responsibility of the aircraft owner and any person who is to perform any maintenance on the aircraft.			

#### PROCEDURE

1. Remove the centre console side inspection panel.
2. Remove split pin and discard (do not re-use).
3. Inspect all bolts and nuts for damage. Replace if necessary.
4. Adjust castle nut and thickness of washers to attain required friction (refer to Figure 47).
5. To inspect ground run the engine and move throttle lever to arbitrary positions across its complete range of travel, and to the extreme rear position, and verify that adequate friction can be maintained against the carburettor springs.
6. Fit new split pin (do not use previously used split pin).
7. Apply thread locking sealant to the centre console inspection panel screws before fitting.

### 5.2.19.2 THROTTLE LEVER FRICTION DISC REPLACEMENT

TOOLS / EQUIPMENT REQUIRED			
ITEM	QUANTITY	NOTES	
1	3/8 Spanner	2	
2	2 mm Allen key, 2.5 mm Allen key	1 each	Inspection panel screws.
The above list is not necessarily a complete list of all required tools and equipment needed. A calibrated torque wrench (with adequate range) and the correct size (as implied by the above tool list) accessories (sockets etc.) are implied for torquing bolts / nuts, if applicable. Refer to paragraph 1.5 for torque values.			
CONSUMABLE MATERIAL REQUIRED			
ITEM	QUANTITY	NOTES	
1	Split pin	1.	
2	Loctite 222	As needed	Centre console inspection panel.
The above list is not necessarily a complete list of all material needed. Refer to the Sling 2 construction manual.			
AUTHORISED PERSONNEL			
Any person performing maintenance of any kind on the aircraft or any component thereof must do so in accordance with national legislation. This is the responsibility of the aircraft owner and any person who is to perform any maintenance on the aircraft.			

## PROCEDURE (REMOVAL)

Retain any bolts, clamps, spacers, screws and washers (with the exception of lock-washers) for reassembly.

1. Remove the centre console side inspection panel.
2. Remove the split pin and discard.
3. Undo the castle nut, support the throttle lever and pull out the bolt, and remove the friction washers.

## PROCEDURE (INSTALLATION)

1. Reverse the above procedure (removal), paying close attention to the following:
  - Do not re-use split pin. Fit new.
  - Inspect castle nut and bolt for damage. Replace if necessary.
2. Adjust the throttle lever friction (refer to paragraph 5.2.19.1).

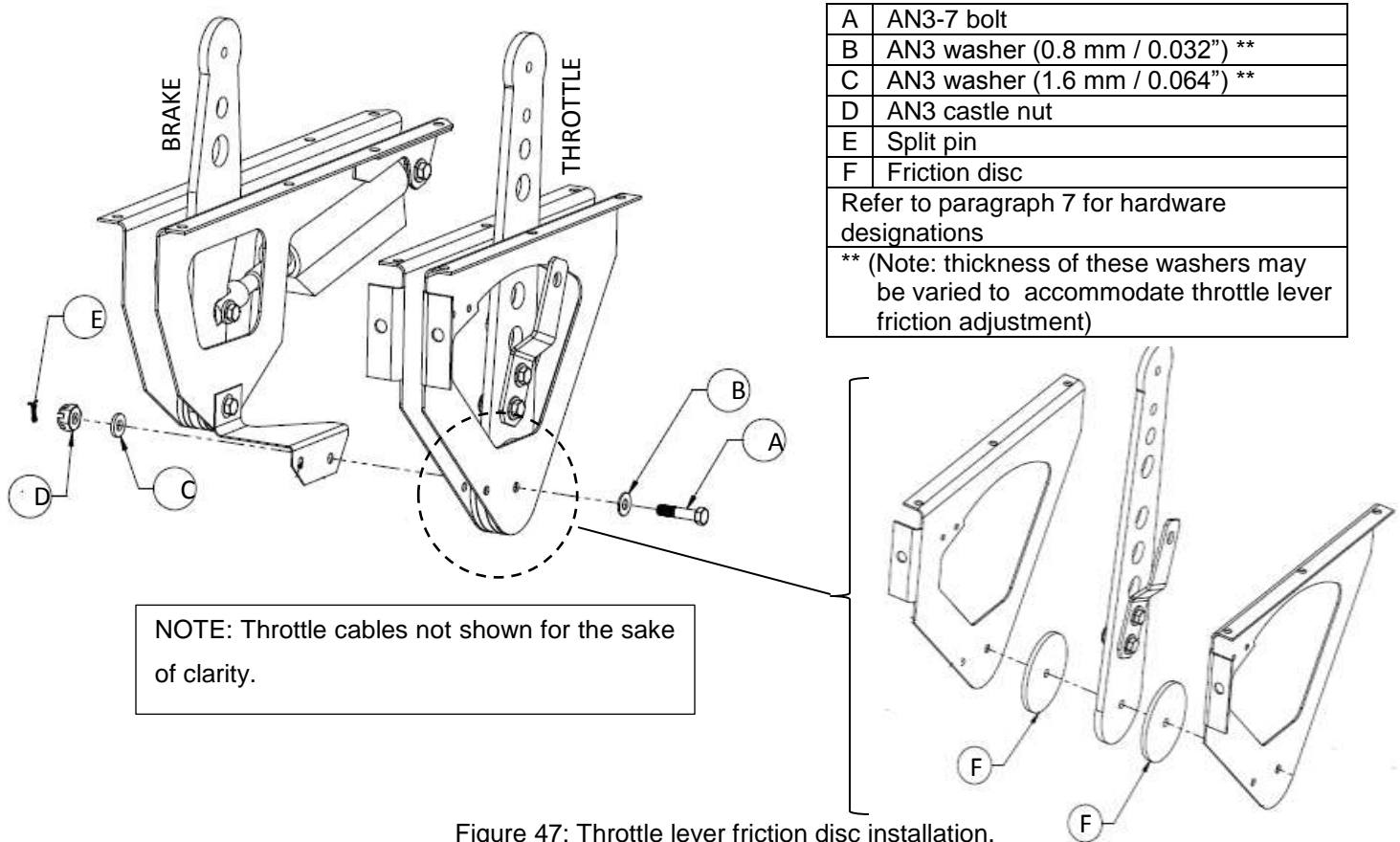

Figure 47: Throttle lever friction disc installation.

### 5.3 PROPELLER

The aircraft is fitted with one of the following propellers:

1. Three blade Airmaster 332 72" variable pitch / constant speed propeller, controllable from the cabin. Refer to the latest revision of the propeller operator's manual for detailed information.
2. Three blade Warp Drive 72" fixed pitch (ground adjustable) propeller.
3. Whirlwind GA RW3B-RW three blade 70" fixed pitch (ground adjustable) propeller.

Refer to the latest revision of the propeller operator's manual / installation instructions for detailed information.

#### 5.3.1 GENERAL MAINTENANCE AND SERVICE

Refer to and comply with the latest revision of the propeller operator's manual / installation and operation manual for service requirements and procedures.

#### 5.3.2 PROPELLER HUB AND PROPELLER EXTENSION TORQUE PATTERN

Bolts / nuts should be torqued in the following sequence (as indicated in Figure 48) when securing the propeller extension to the engine hub or when securing a propeller to the propeller extension.

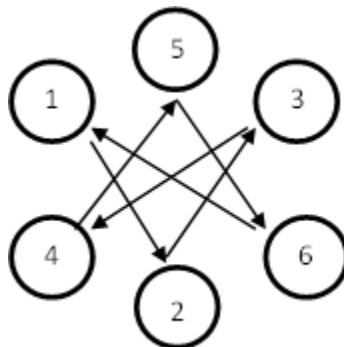

Figure 48: Propeller installation / propeller extension installation torque pattern.

**5.3.3 SPINNER REMOVAL / REPLACEMENT**

TOOLS / EQUIPMENT REQUIRED		
ITEM	QUANTITY	NOTES
1	Phillips screwdriver.	1
<p>The above list is not necessarily a complete list of all required tools and equipment needed. A calibrated torque wrench (with adequate range) and the correct size (as implied by the above tool list) accessories (sockets etc.) are implied for torquing bolts / nuts, if applicable. Refer to paragraph 1.5 for torque values.</p>		
AUTHORISED PERSONNEL		
<p>Any person performing maintenance of any kind on the aircraft or any component thereof must do so in accordance with national legislation. This is the responsibility of the aircraft owner and any person who is to perform any maintenance on the aircraft.</p>		

**WARNING**  
**MASTER / IGNITION SWITCHES OFF.**

### PROCEDURE (REMOVAL)

Retain any bolts, nuts (except lock-nuts) spacers, screws and washers (with the exception of lock-washers) for reassembly.

1. Undo the screws (1) retaining the spinner (2) to the spinner bulkhead (3).

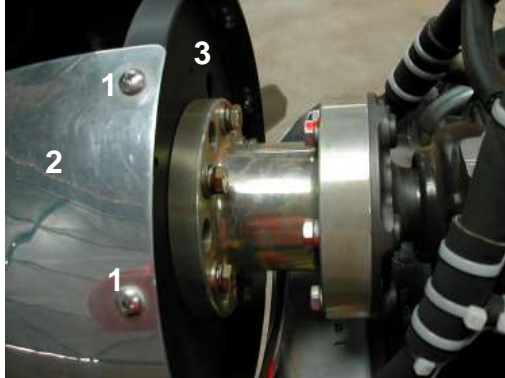

### PROCEDURE (INSTALLATION)

1. Reverse the above procedure (removal) to install the spinner, paying close attention to the following:
  - Inspect all bolts, nuts and screws for damage, cracks, corrosion, proper thread and cleanliness. Replace if necessary.
  - Inspect the spinner bulkhead and spinner dome for cracks, deformations or any signs of damage.

**5.3.4 GENERAL CONSIDERATIONS / INFORMATION WHEN FITTING A PROPELLER EXTENSION TO THE ENGINE FLANGE**

BOLT SIZE / TYPE FOR TING PROPELLER EXTENSION TO ENGINE FLANGE / ENGINE FLANGE LUGS	
PROPELLER EXTENSION FITTED DIRECTLY TO ENGINE FLANGE / LUGS	SLIP RING DISC OR EXTERNAL ALTERNATOR DRIVE PULLEY FITTED BETWEEN ENGINE FLANGE AND PROPELLER EXTENSION
M8 x 40 mm hex bolt, Class 8.8. Apply thread locking sealant (Loctite 243).	M8 x 45 mm hex bolt, Class 8.8. Apply thread locking sealant (Loctite 243).

1. Ensure that the engine flange and propeller extension are clean before joining.
2. Do not reuse locking washers. Fit new.
3. Torque bolts to correct values (refer to paragraph 1.5.2).



**5.3.5 PROPELLER REMOVAL / INSTALLATION (AIRMASTER 332)**

TOOLS / EQUIPMENT REQUIRED			
ITEM		QUANTITY	NOTES
1	<u>Calibrated</u> torque wrench, minimum range of at least 25 Nm.	1	Installation.
2	½ inch Hex socket (to fit item 1).	1	Installation.
3	13 mm Hex socket (to fit item 1).	1	Installation.
4	½ inch Spanner.	1	Removal.
5	13 mm Spanner	1	Removal.
6	Socket wrench to fit items 2 and 3.	1	Alternative to items 4 and 5.

The above list is not necessarily a complete list of all required tools and equipment needed. A calibrated torque wrench (with adequate range) and the correct size (as implied by the above tool list) accessories (sockets etc.) are implied for torquing bolts / nuts, if applicable. Refer to paragraph 1.5 for torque values.

CONSUMABLE MATERIAL REQUIRED			
ITEM		QUANTITY	NOTES
1	Orange paint.	As needed.	
2	Loctite 243.	As needed.	Bolts connecting propeller extension and engine flange.
3	Loctite 222.	As needed.	Bolts connecting propeller extension and propeller assembly / hub.

The above list is not necessarily a complete list of all material needed. Refer to the Sling 2 construction manual.

AUTHORISED PERSONNEL			
Any person performing maintenance of any kind on the aircraft or any component thereof must do so in accordance with national legislation. This is the responsibility of the aircraft owner and any person who is to perform any maintenance on the aircraft.			

**WARNING**  
**MASTER / IGNITION SWITCHES OFF.**

**CAUTION**  
**BE PREPARED WITH A HELPER OR SUPPORT STAND TO HANDLE THE WEIGHT**  
**AND AWKWARDNESS OF THE OBJECT TO BE REMOVED.**

## PROCEDURE (REMOVAL)(STANDARD)

Retain any bolts, nuts (except lock-nuts) spacers, screws and washers (with the exception of lock-washers) for reassembly.

1. Support the propeller and undo the bolts (1) securing the propeller extension (2) to the engine flange (3).

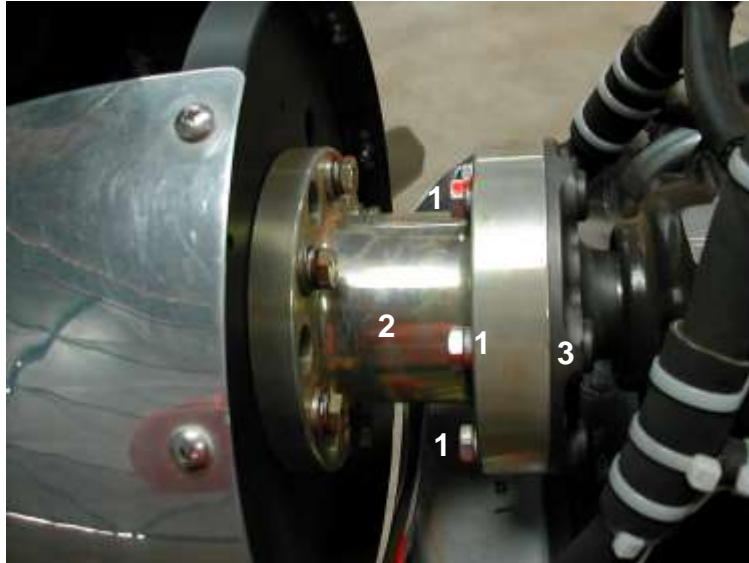

2. Slowly move the propeller assembly away from the engine flange, until the signal wire connections (4) are exposed. Disconnect the wires.



3. After removal, do not lay the propeller down on its tip (against a wall for instance) but always lay the propeller flat and away from sources of humidity, heat or, in any case, away from areas subject to excessive temperature variations.

## PROCEDURE (INSTALLATION)(STANDARD)

1. Reverse the above procedure (removal) to install the propeller onto the engine, paying close attention to the following:
  - Do not reuse lock-washers. Fit new.
  - Inspect all bolts, nuts and screws for damage, cracks, corrosion, proper thread and cleanliness. Replace if necessary.
  - Apply Loctite 243 to bolt threads before fitting to the propeller extension / engine flange.
  - Inspect the spinner bulkhead and spinner dome for cracks, deformations or any signs of damage.
  - Inspect the spinner dome for security of attachment. Inspect the balance weight bolt / nut for security of attachment.
  - Carefully clean and dry the engine flange and propeller extension. Ensure that no oil traces are present.
  - Inspect the electrical wire connections terminals for damage and security of attachment to the wires.
  - Ensure that the electrical signal wire connections are secure and correct (i.e. a specific coloured wire on the propeller side connects to the same colour wire on the engine side).
  - Ensure that the propeller extension is correctly aligned with engine flange before tightening the bolts.
  - Observe washer placement (refer to Figure 49). Torque the bolts to the correct value (refer to paragraph 1.5.2). Torque in a star pattern / sequence as shown in Figure 48.

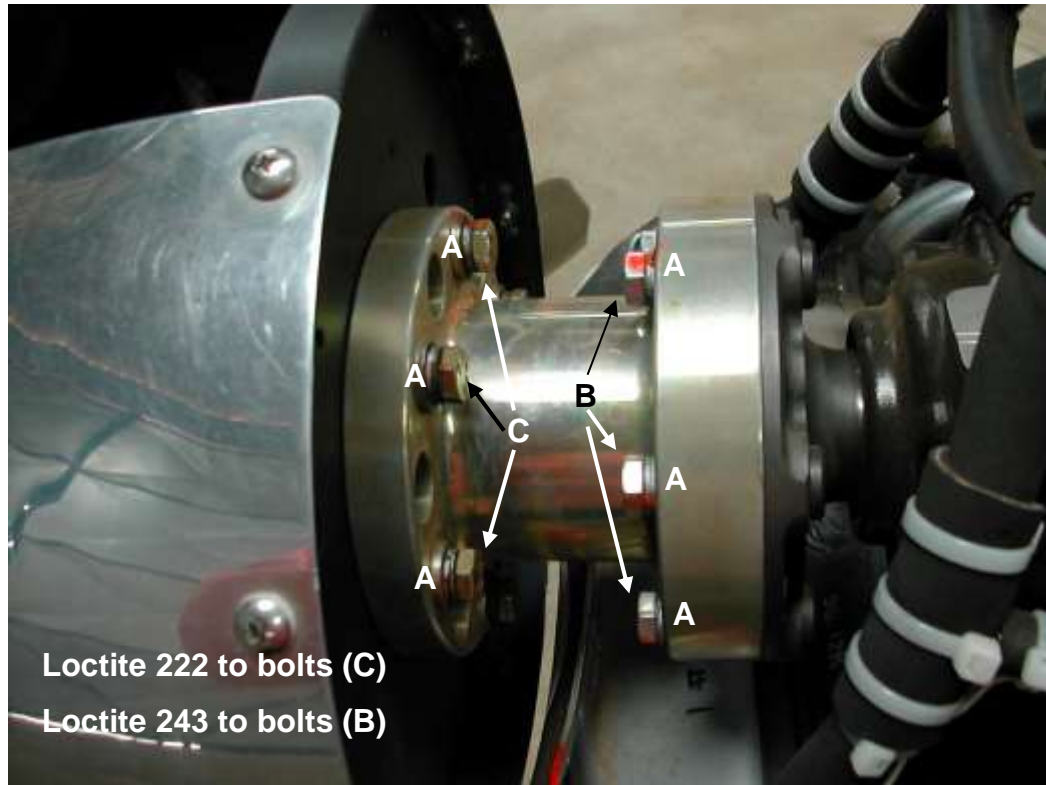

A	2 x 8 mm Wedge lock-washer
B	M8 x 40 mm bolt, Class 8.8.
C	AN5-15A bolt.

Figure 49: Airmaster propeller installation (standard).

2. Paint orange creep marks on the bolts.
3. Before flight, start and let the engine run for a few minutes, operate the propeller controls to verify correct operation, stop the engine and carry out an inspection (tightness of bolts, spinner security of attachment, overall state, etc.).

## PROCEDURE (REMOVAL) (WITH VACUUM PUMP FITTED)

Retain any bolts, nuts (except lock-nuts) spacers, screws and washers (with the exception of lock-washers) for reassembly.

### REMOVING WITHOUT PROPELLER EXTENSION

1. Support the propeller and undo the bolts (1) securing the propeller assembly to the propeller extension (2).
2. Carefully and slowly pull the propeller away from the propeller extension (2) until the signal wire connectors are exposed. Disconnect the wires.

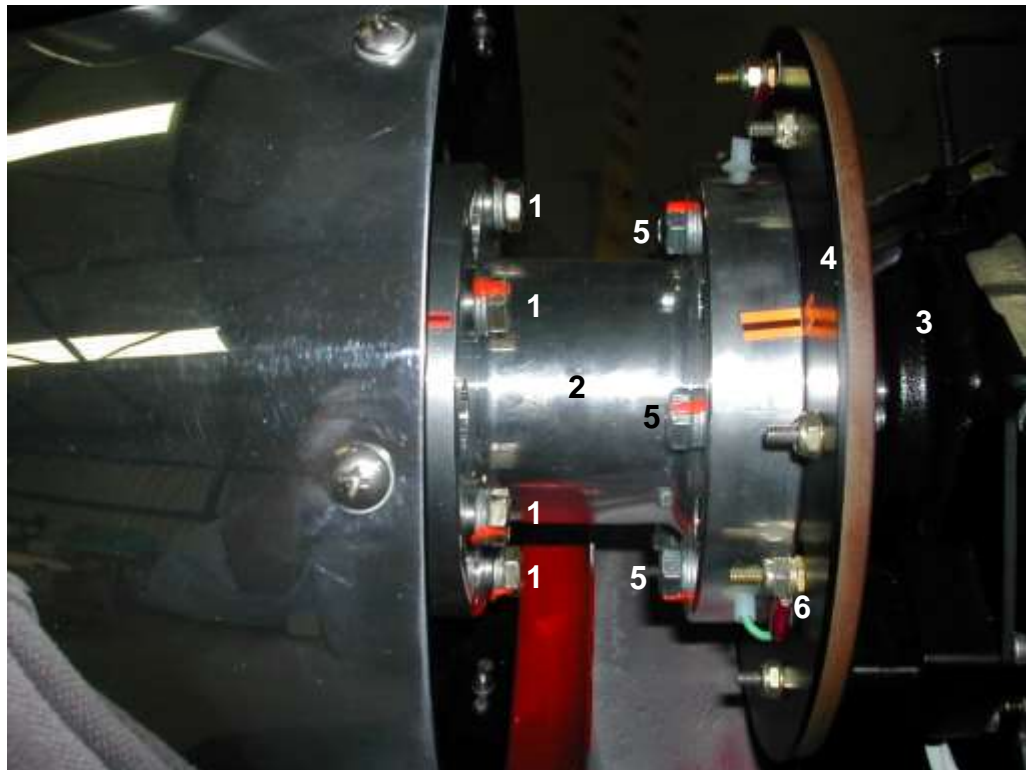

### REMOVING AT ENGINE FLANGE SIDE (WITH PROPELLER EXTENSION ATTACHED) / REMOVING SLIP-RING DISC

1. Refer to step 4 below.
2. Support the propeller and undo the bolts (5) securing the propeller extension (2) to the engine flange (3).
3. Support the propeller assembly and carefully move the propeller assembly (and slip-ring disc, if still attached via the signal wires) away from the engine flange.

4. If required to separate the slip-ring disc (4) from the propeller extension, undo the nuts (6) securing the signal wires (from the propeller extension) to the slip-ring disc. Before doing so, use coloured stickers or paint to mark the connection of the coloured signal wires to the disc terminals / connections, or place an alignment mark on the propeller extension and slip-ring disc.
5. After removal, do not lay the propeller down on its tip (against a wall for instance) but always lay the propeller flat and away from sources of humidity, heat or, in any case, away from areas subject to excessive temperature variations.

#### PROCEDURE (INSTALLATION) (WITH VACUUM PUMP FITTED)

4. Reverse the above procedure (removal) to install the propeller onto the engine, paying close attention to the following:
  - Do not reuse lock-washers and lock-nuts. Fit new.
  - Inspect all bolts, nuts and screws for damage, cracks, corrosion, proper thread and cleanliness. Replace if necessary.
  - Apply thread locking sealant to the bolt threads before fitting.
  - Inspect the spinner bulkhead and spinner dome for cracks, deformations or any signs of damage.
  - Inspect the spinner dome for security of attachment. Inspect the balance weight bolt / nut for security of attachment.
  - Carefully clean and dry the engine flange, propeller extension and slip-ring disc. Ensure that no oil traces are present.
  - Inspect the electrical wire connections terminals for damage and security of attachment to the wires.
  - Ensure that the electrical signal wire connections are secure and correct (i.e. a specific coloured wire on the propeller / propeller extension side connects to the correct slip-ring / terminal on the slip-ring disc (as marked upon removal, or refer to Figure 50).

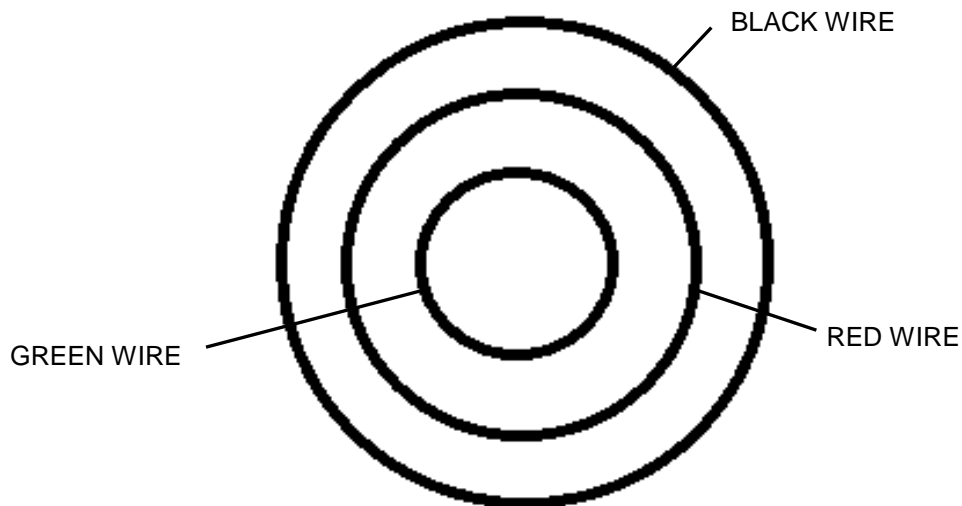

Figure 50: Airmaster propeller signal wire to slip-ring disc connection (vacuum pump fitted).

- Ensure that the propeller extension is correctly aligned with engine flange before tightening the bolts.
- Observe washer placement (refer to Figure 51). Torque the bolts to the correct value (refer to paragraph 1.5.2). Torque in a star pattern / sequence as shown in Figure 48.

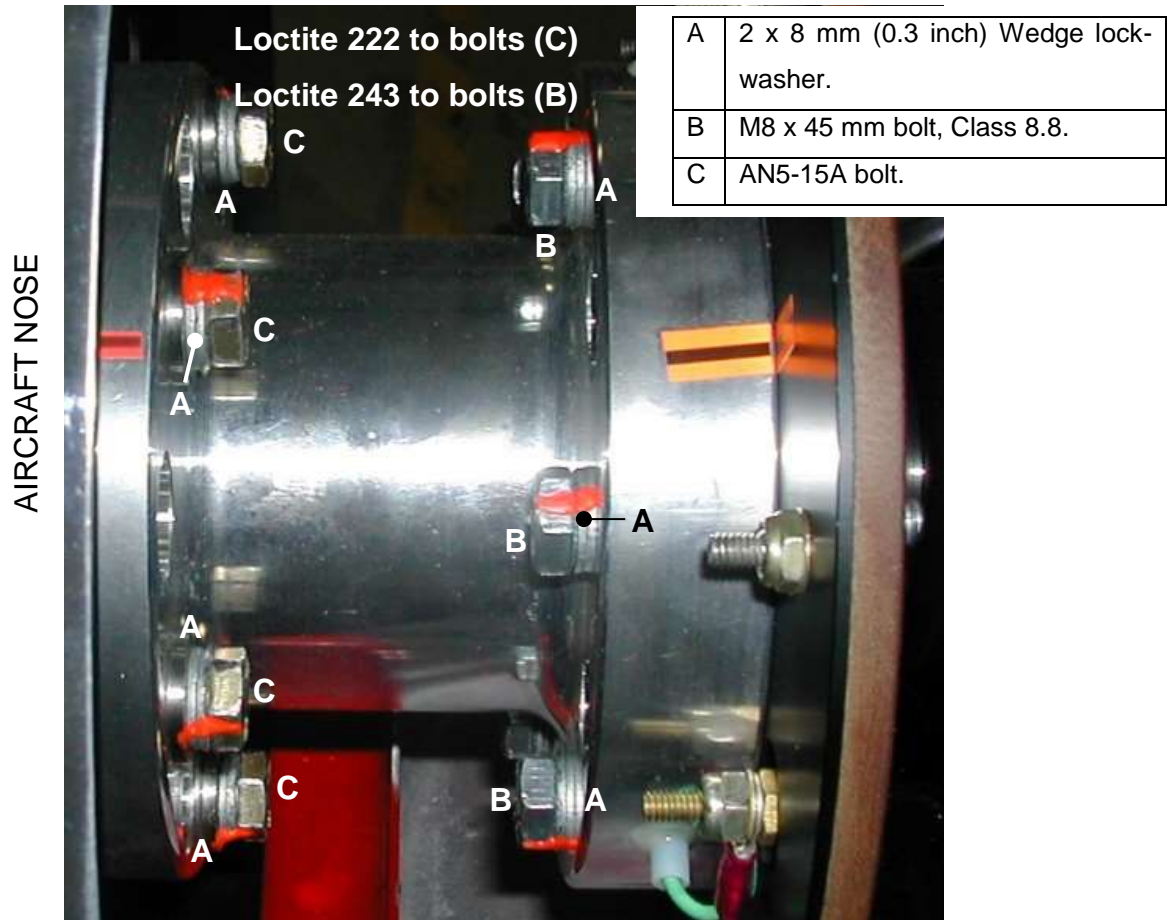

Figure 51: Airmaster propeller installation (with vacuum pump fitted).

5. Paint orange creep marks on the bolts.
6. After the correct installation of the propeller and before flight, inspect for security of attachment of the propeller, correct and secure attachment of the signal wires and for any damage which may have been incurred during the installation procedure. Apply electrical power and operate the propeller controls to verify correct operation.
7. Before flight, start and let the engine run for a few minutes, operate the propeller controls to verify correct operation, stop the engine and carry out an inspection (tightness of bolts, spinner security of attachment, overall state, etc.).



**PROCEDURE (REMOVAL) (WITH EXTERNAL ALTERNATOR FITTED)**

Retain any bolts, nuts (except lock-nuts) spacers, screws and washers (with the exception of lock-washers) for reassembly.

The procedure is in general the same as that for the standard installation removal. When the bolts joining the propeller extension, alternator drive pulley and engine flange / engine flange lugs are removed, the alternator drive pulley can be separated, but cannot be removed from the engine without further disassembly.

**PROCEDURE (INSTALLATION) (WITH EXTERNAL ALTERNATOR FITTED)**

The procedure is in general the same as that for the standard installation. Note that a longer bolt is used to secure the propeller extension to the engine flange / engine flange lugs (refer to paragraph 5.3.4).

- Do not reuse lock-washers. Fit new.
- Observe correct washer placement (refer to Figure 52).
- Inspect all bolts, nuts and screws for damage, cracks, corrosion, proper thread and cleanliness. Replace if necessary.
- Apply Loctite 243 to bolt threads before fitting to the propeller extension / engine flange.

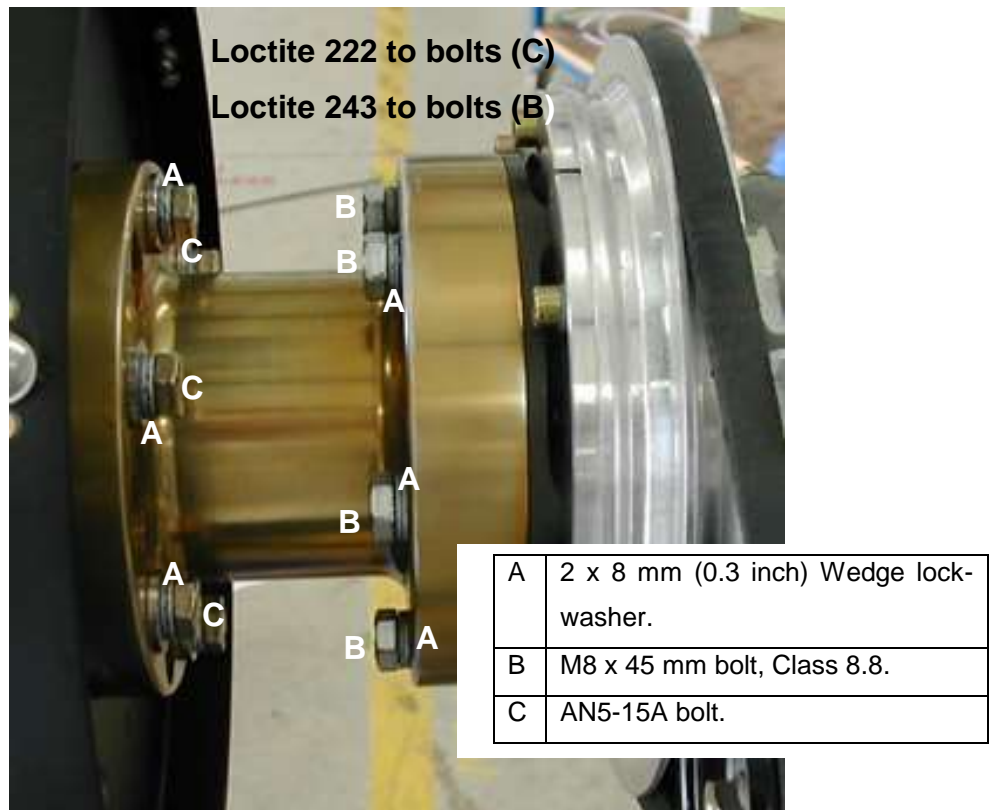

Figure 52: Airmaster propeller installation (external alternator fitted).

### 5.3.6 PROPELLER REMOVAL / INSTALLATION (WHIRLWIND)

TOOLS / EQUIPMENT REQUIRED			
ITEM		QUANTITY	NOTES
1	Calibrated torque wrench, minimum range of at least 25 Nm.	1	Installation only.
2	6 mm Hex drive (to fit item 1).	1	
3	13 mm Spanner.	1	
4	6 mm Allen key / hex drive.	1	
<p>The above list is not necessarily a complete list of all required tools and equipment needed. A calibrated torque wrench (with adequate range) and the correct size (as implied by the above tool list) accessories (sockets etc.) are implied for torquing bolts / nuts, if applicable. Refer to paragraph 1.5 for torque values.</p>			
CONSUMABLE MATERIAL REQUIRED			
ITEM		QUANTITY	NOTES
1	Orange paint.	As needed.	
<p>The above list is not necessarily a complete list of all material needed. Refer to the Sling 2 construction manual.</p>			
AUTHORISED PERSONNEL			
<p>Any person performing maintenance of any kind on the aircraft or any component thereof must do so in accordance with national legislation. This is the responsibility of the aircraft owner and any person who is to perform any maintenance on the aircraft.</p>			

**WARNING**  
**MASTER / IGNITION SWITCHES OFF.**

**CAUTION**  
**BE PREPARED WITH A HELPER OR SUPPORT STAND TO HANDLE THE WEIGHT AND AWKWARDNESS OF THE OBJECT TO BE REMOVED.**

## PROCEDURE (REMOVAL)

Retain any bolts, nuts (except lock-nuts) spacers, screws and washers (with the exception of lock-washers) for reassembly.

1. Remove the spinner (refer to paragraph 5.3.3).
2. Support the propeller and undo the bolts / nuts retaining the propeller hub to the propeller extension, remove the bolts and carefully pull the propeller from the propeller extension studs / lugs.
3. Remove the spacer / faceplate (1) and propeller spinner bulkhead (2).



4. After removal, do not lay the propeller down on its tip (against a wall for instance) but always lay the propeller flat and away from sources of humidity, heat or, in any case, away from areas subject to excessive temperature variations.

## PROCEDURE (INSTALLATION)

1. Reverse the above procedure (removal) to install the propeller onto the engine, paying close attention to the following:
  - Do not reuse lock-washers and lock nuts. Fit new.
  - Inspect all bolts, nuts and screws for damage, cracks, corrosion, proper thread and cleanliness. Replace if necessary.
  - Inspect the spinner bulkhead, spacer and spinner dome for cracks, deformations or any signs of damage.
  - Inspect the spinner dome for security of attachment.

- Carefully clean and dry the propeller hub and propeller extension before fitment. Ensure that no oil traces are present.
- Observe washer placement (refer to Figure 53). Torque the bolts / nuts to the correct value (refer to paragraph 1.5.2). Torque in a star pattern / sequence as shown in Figure 48.

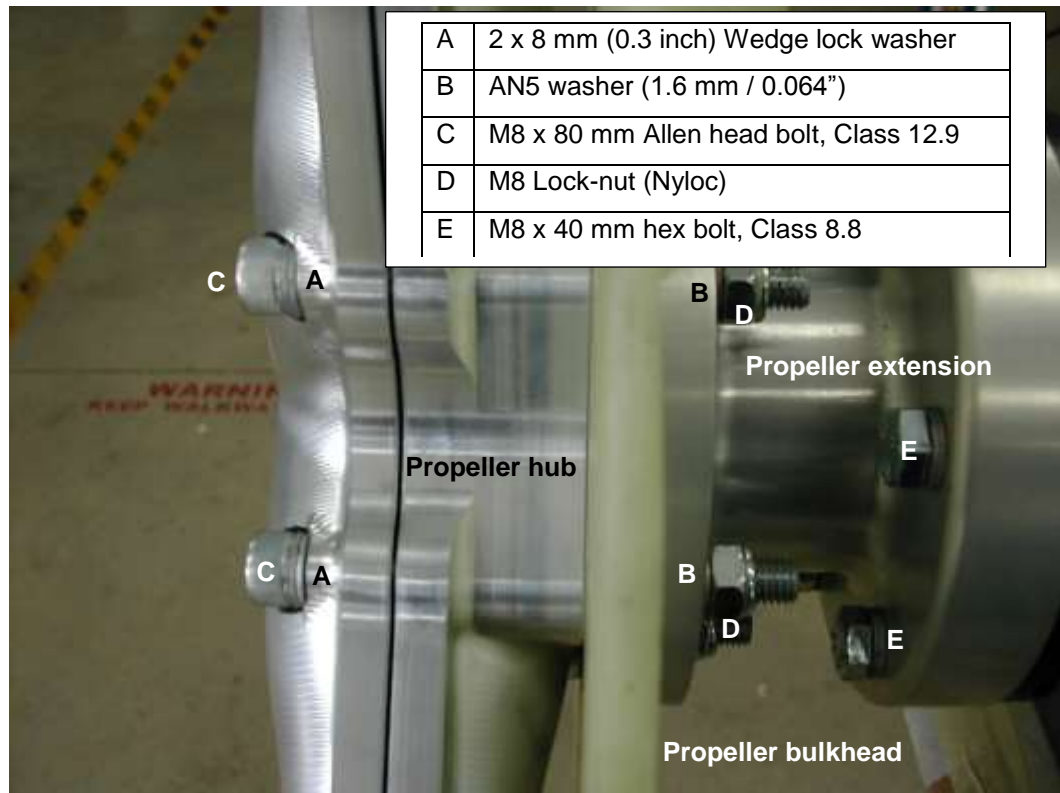

Figure 53: Whirlwind propeller installation.

2. Paint orange creep marks on the bolts / nuts.
3. After the correct installation of the propeller and before flight, inspect for security of attachment or any damage which may have been incurred during the installation procedure.
4. Before flight, start and let the engine run for a few minutes. Stop the engine and carry out an inspection (tightness of bolts, spinner security of attachment, overall state, etc.).

**5.3.7 PROPELLER REMOVAL / INSTALLATION (WARP DRIVE)**

TOOLS / EQUIPMENT REQUIRED			
ITEM	QUANTITY	NOTES	
1	Calibrated torque wrench, minimum range of at least 25 Nm.	1	Installation.
2	13 mm Hex socket (to fit item 1).	1	Installation.
3	13 mm Spanner.	2	Removal.
<p>The above list is not necessarily a complete list of all required tools and equipment needed. A calibrated torque wrench (with adequate range) and the correct size (as implied by the above tool list) accessories (sockets etc.) are implied for torquing bolts / nuts, if applicable. Refer to paragraph 1.5 for torque values.</p>			
CONSUMABLE MATERIAL REQUIRED			
ITEM	QUANTITY	NOTES	
1	Orange paint.	As needed.	
<p>The above list is not necessarily a complete list of all material needed. Refer to the Sling 2 construction manual.</p>			
AUTHORISED PERSONNEL			
<p>Any person performing maintenance of any kind on the aircraft or any component thereof must do so in accordance with national legislation. This is the responsibility of the aircraft owner and any person who is to perform any maintenance on the aircraft.</p>			

**WARNING**  
**MASTER / IGNITION SWITCHES OFF.**

**CAUTION**  
**BE PREPARED WITH A HELPER OR SUPPORT STAND TO HANDLE THE WEIGHT AND AWKWARDNESS OF THE OBJECT TO BE REMOVED.**

### PROCEDURE (REMOVAL)

Retain any bolts, nuts (except lock-nuts) spacers, screws and washers (with the exception of lock-washers) for reassembly.

The procedure and considerations are generally the same as that for removing the Whirlwind propeller (refer to paragraph 5.3.6).

### PROCEDURE (INSTALLATION)

The procedure and considerations are generally the same as that for installing the Whirlwind propeller (refer to paragraph 5.3.6), with the following exceptions:

- A longer bolt is used to secure the propeller hub to the propeller extension. Note that a M8 x 90 mm hex head bolt, Class 8.8 is used.
- A thicker spacer is used between the spinner bulkhead and the propeller hub.

Pay close attention to the following:

- Do not reuse lock-washers and lock nuts. Fit new.
- Torque the bolts to the correct value (refer to paragraph 1.5.2).

**5.3.8 PROPELLER ASSEMBLY / DISASSEMBLY (AIRMASTER 332)**

TOOLS / EQUIPMENT REQUIRED			
ITEM	QUANTITY	NOTES	
1	Calibrated torque wrench, with a minimum range of at least 25 Nm.	1	Installation only.
2	½ inch Hex socket (to fit item 1).	1	
3	½ inch Spanner.	1	
4	Socket wrench to fit item 2.	1	Alternative to item 3.
<p>The above list is not necessarily a complete list of all required tools and equipment needed. A calibrated torque wrench (with adequate range) and the correct size (as implied by the above tool list) accessories (sockets etc.) are implied for torquing bolts / nuts, if applicable. Refer to paragraph 1.5 for torque values.</p>			
CONSUMABLE MATERIAL REQUIRED			
ITEM	QUANTITY	NOTES	
1	Orange paint.	As needed.	
2	Loctite 222.	As needed.	
<p>The above list is not necessarily a complete list of all material needed. Refer to the Sling 2 construction manual.</p>			
AUTHORISED PERSONNEL			
<p>Any person performing maintenance of any kind on the aircraft or any component thereof must do so in accordance with national legislation. This is the responsibility of the aircraft owner and any person who is to perform any maintenance on the aircraft.</p>			

**CAUTION**

**BE PREPARED WITH A HELPER OR SUPPORT STAND TO HANDLE THE WEIGHT AND / OR AWKWARDNESS OF THE OBJECT TO BE REMOVED / INSTALLED.**

### PROCEDURE (DISASSEMBLY)

Retain any bolts, nuts (except lock-nuts) spacers, screws and washers (with the exception of lock-washers) for reassembly.

1. Remove the spinner dome (refer to paragraph 5.3.3).
2. Remove the propeller assembly from the aircraft (refer to paragraph 5.3.5).
3. Unfasten the bolts (1) that secure the propeller assembly (2) to the propeller extension (3) and remove the propeller and spinner bulkhead.

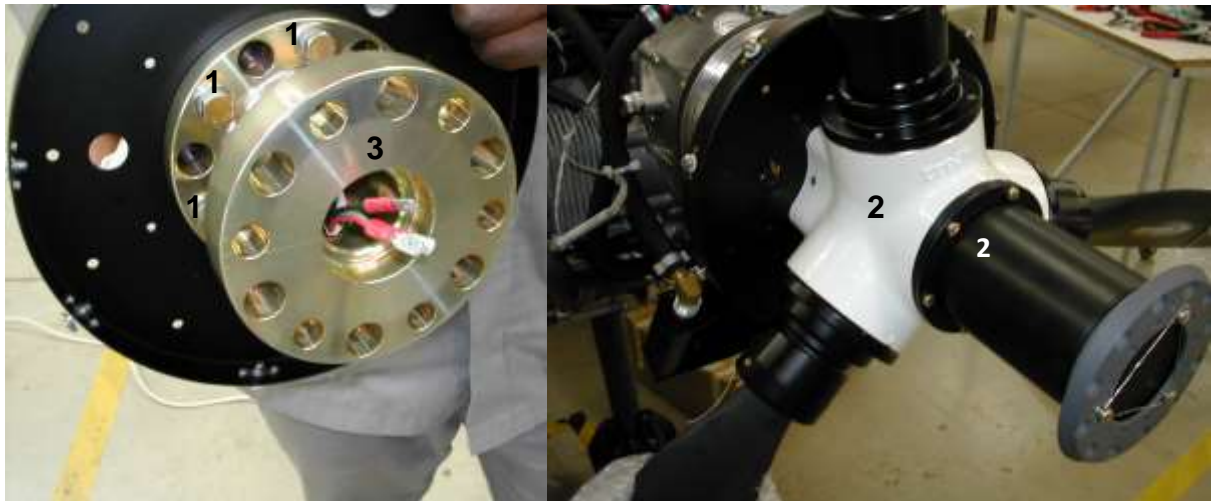

4. For further disassembly of the propeller assembly (2) refer to the latest revision of the propeller manufacturer operator's manual for the required procedures and instructions.

### PROCEDURE (ASSEMBLY)

1. Reverse the above procedure (disassembly) to reassemble the propeller assembly, paying close attention to the following:
  - Do not reuse lock-washers. Fit new.
  - Inspect all bolts, nuts and screws for damage, cracks, corrosion, proper thread and cleanliness. Replace if necessary.
  - Apply Loctite 222 to the bolts before fitting to the propeller extension / propeller assembly.



- Carefully clean and dry the propeller extension and spinner hub. Ensure that no oil traces are present.
- Inspect the spinner dome, the spinner bulkhead and propeller extension for cracks, deformations or signs of any damage.
- Ensure that the propeller extension is correctly aligned with propeller assembly / hub before tightening the bolts.
- Observe washer placement (refer to Figure 49). Torque the bolts securing the propeller assembly to the propeller extension to the correct value (refer to paragraph 1.5.2). Torque in a star pattern / sequence as shown in Figure 48.

#### **5.3.9 PROPELLER ASSEMBLY / DISASSEMBLY (WARP DRIVE)**

Refer to the latest revision of the propeller manufacturer operator manual / installation and operation instructions for the relevant procedures and instructions.

#### **5.3.10 PROPELLER ASSEMBLY / DISASSEMBLY (WHIRLWIND)**

Refer to the latest revision of the propeller manufacturer operator manual / installation and operation instructions for the relevant procedures and instructions.

#### **5.3.11 PROPELLER ADJUSTMENT / SET-UP**

Refer to the latest revision of the propeller manufacturer operator manual / installation and operation instructions for the relevant procedures and instructions.

#### **5.3.12 PROPELLER BALANCING**

Refer to the latest revision of the propeller manufacturer operator manual / installation and operation instructions for the relevant procedures and instructions.

**6. FUEL SYSTEM**

**6.1 GENERAL INFORMATION AND CONSIDERATIONS**

FUEL HOSE / PIPE		TWO-EAR CLAMPS
INNER DIAMETER	OUTER DIAMETER	
6 mm	12.5 mm (approximately)	13 mm
8 mm	14.5 (approximately)	15 mm

When tie wrapping fuel pipes to the engine mount, other pipes or the aircraft structure to aid in routing / security of attachment, care should be taken that the inside cross sectional area of the pipe is not distorted to such an extent that it impedes or hampers the flow of fuel in any way.

For fuel feed and return line hose sizes / diameters refer to Figure 60.

**914 UL ENGINE (SLING 2):**

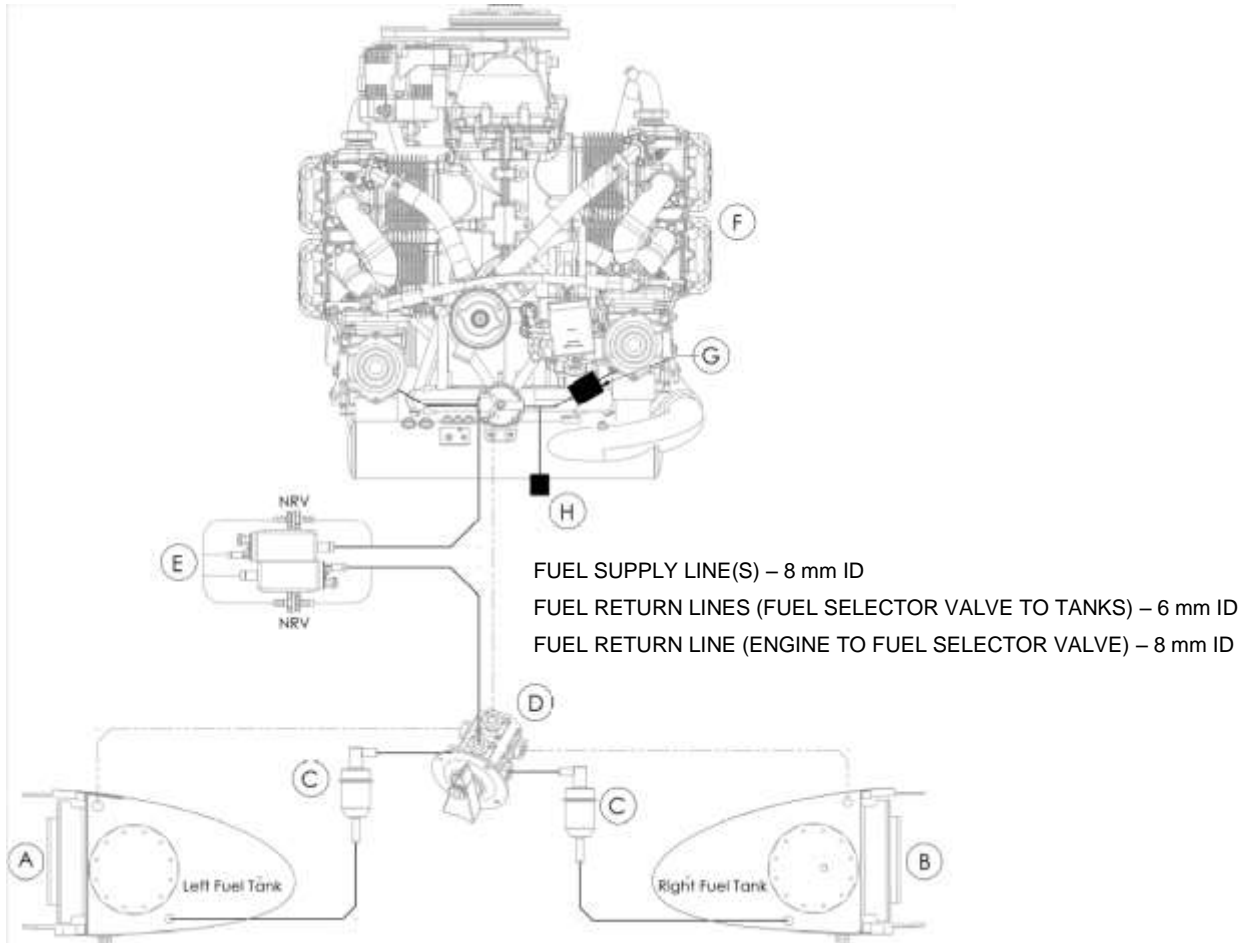

A	Left fuel tank	F	Rotax 914 UL engine
B	Right fuel tank	G	Fuel flow sensor
C	Fuel filter(s)	H	Fuel pressure sensor
D	Fuel selector (LEFT, RIGHT, OFF)	—	Fuel line to carburetors ( 8 mm inner diameter)
E	Electric fuel pumps (fuel pump assembly)	— .. —	Fuel return line: (6 mm inner diameter from fuel selector to tanks) (8 mm inner diameter from engine to fuel selector)

Figure 54: Fuel system (914 UL - SLING 2).

Refer to Figure 54. The aircraft is equipped with two aluminium fuel tanks (A, B) within the wing leading edges, accessible for inspection through dedicated panels.

The fuel outlet for each tank is located at the lowest point of the inboard sidewall of the tank (A, B).

An inline mesh fuel filter (C) is fitted (in the centre console between the two front seats) in the fuel line from each tank (A, B) to a fuel selector valve (D), which is mounted on the lower centre instrument panel in the cockpit.

Fuel feed is through two electric pumps (E). Each pump has a parallel installed check valve (NRV).

The main fuel feed from the fuel pumps (E) enters a fuel pressure controller mounted on the engine (F), whereafter it splits into two separate branches, one for each carburettor. A fuel pressure transducer (H) is connected to one fuel pipe branch and is connected to the EFIS / iBOX via the RDAC unit. A fuel flow transducer (G) is connected in the one fuel pipe branch and is connected to the EFIS / iBOX via the RDAC unit.

Surplus fuel returns from the fuel pressure controller to the tank (A, B) in use (as selected by the fuel selector (D)) via a fuel return line to the upper inboard section of each tank (A, B).

Fuel drain valves are located under the inner leading edge section of each wing, just forward of the main spar.

Each fuel tank (A, B) is equipped with an individual float sensor. Fuel level indicators for each tank appear on the EFIS display.

**912 ULS ENGINE (SLING 2):**

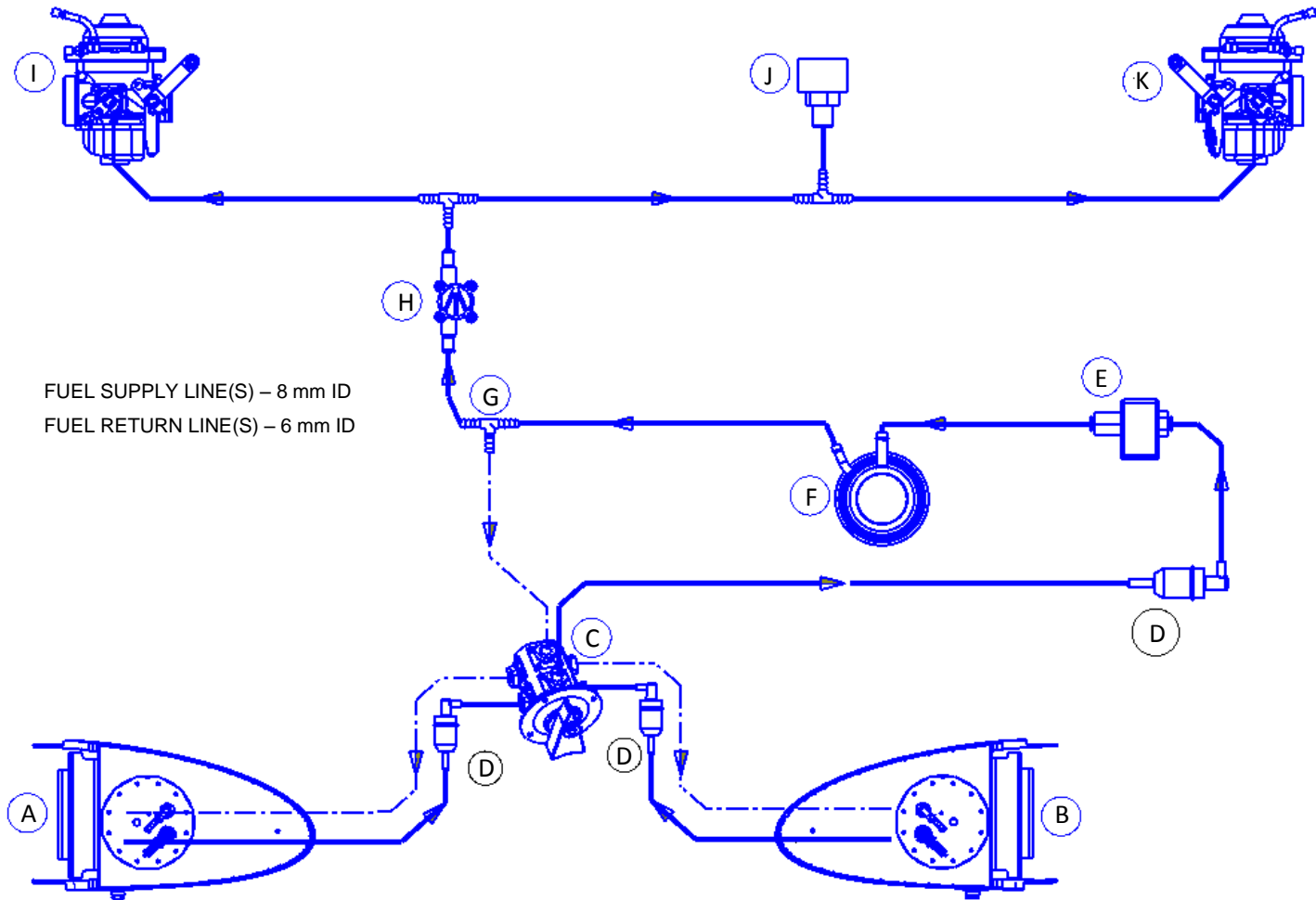

A	Port (left) fuel tank	G	Barbed T-piece
B	Starboard (right) fuel tank	H	Fuel flow sensor
C	Fuel selector (LEFT, RIGHT, OFF)	I	Port (left) carburettor
D	Fuel filter (90° bend)	J	Fuel pressure sensor
E	Electric fuel pump	K	Starboard (right) carburettor
F	Mechanical fuel pump		

Figure 55: Fuel system (912 ULS - SLING 2).

Refer to Figure 55. The aircraft is equipped with two aluminium fuel tanks (A, B) within the wing leading edges, accessible for inspection through dedicated panels.

The fuel outlet for each tank (A, B) is located at the lowest point of the inboard sidewall of the tank (A, B). A finger strainer is fitted to each tank fuel pick-up.

A fuel line from each tank (A, B) feeds into a fuel selector valve (C), which is mounted on the lower centre instrument panel in the cockpit.

Fuel feed is through two series connected pumps, a main mechanical pump (F) and an auxiliary electrical pump (E) (activated by a switch on the instrument panel).

An inline mesh fuel filter (D) is fitted between each fuel tank and the fuel selector valve (C).

An inline mesh fuel filter (D) is fitted between the fuel selector valve and the electrical fuel pump.

The main fuel feed from the fuel pumps enters a fuel flow sensor (H), whereafter it splits into two separate branches, one for each carburettor. The fuel flow sensor (H) is connected to the EFIS / iBOX via the RDAC unit.

A fuel pressure transducer (J) is connected to one fuel pipe branch and is connected to the EFIS / iBOX via the RDAC unit.

Surplus fuel returns from the outlet of the mechanical pump (F) / inlet of the fuel flow sensor (H) to the tanks (A, B) via a fuel return line. The fuel return line splits at the fuel selector (C) to return fuel to the upper inboard section of the tank (A, B) in use.

Fuel drain valves are located under the inner leading edge section of each wing, just forward of the main spar.

Each fuel tank (A, B) is equipped with an individual float sensor. Fuel level indicators for each tank appear on the EFIS display.

**912 iS ENGINE (SLING 2):**

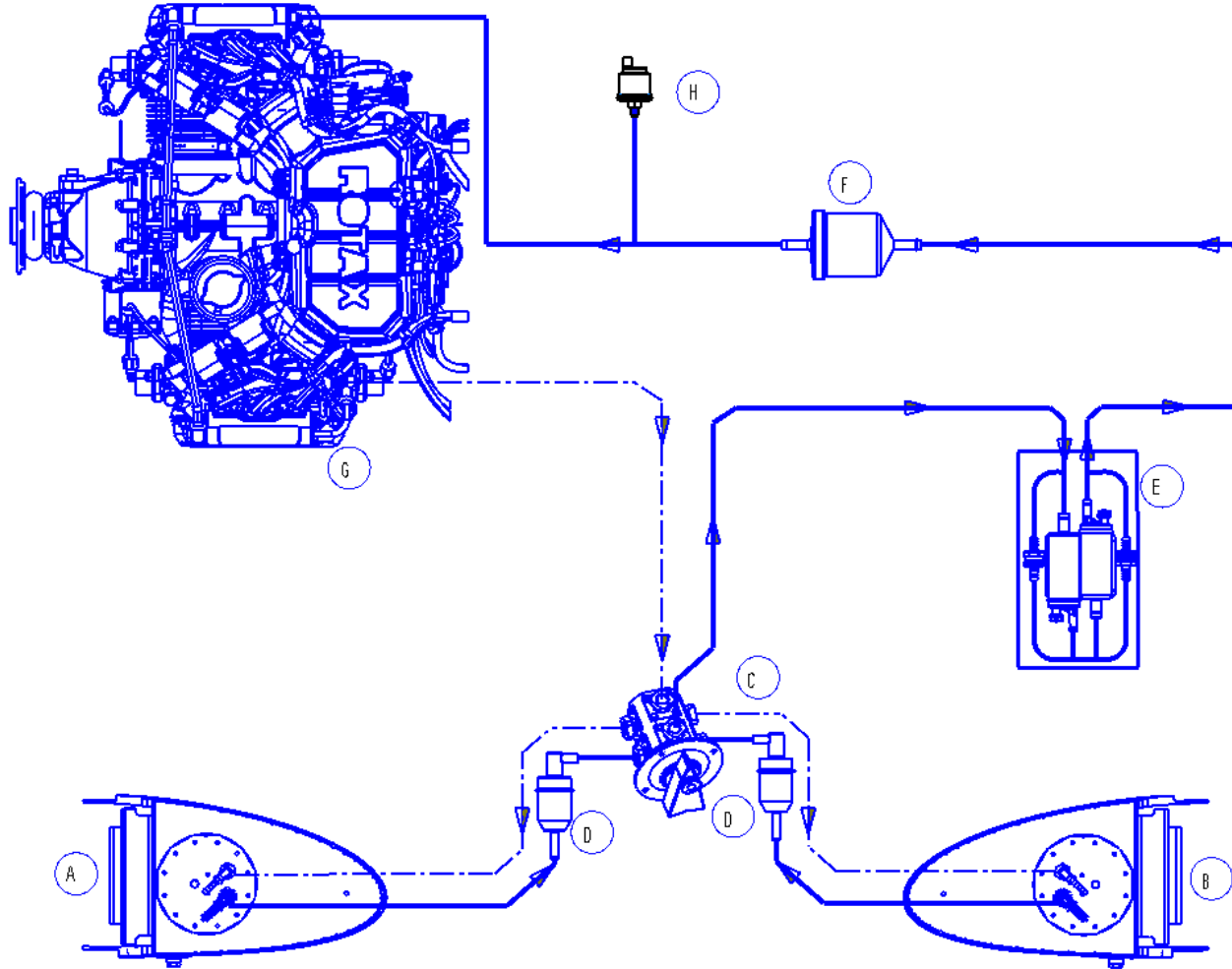

A	Port (left) fuel tank	F	Fuel filter
B	Starboard (right) fuel tank	G	912 iS engine
C	Fuel selector (LEFT, RIGHT, OFF)	H	Fuel pressure transducer
D	Fuel filter (90° bend)		
E	Fuel pump assembly		

Figure 56: Fuel system (912 iS - SLING 2).



Refer to Figure 56. The aircraft is equipped with two aluminium fuel tanks (A, B) within the wing leading edges, accessible for inspection through dedicated panels.

The fuel outlet for each tank (A, B) is located at the lowest point of the inboard sidewall of the tank (A, B). A finger strainer is fitted to each tank fuel pick-up.

A fuel line from each tank (A, B) feeds into a fuel selector valve (C), which is mounted on the lower centre instrument panel in the cockpit.

An inline mesh fuel filter (D) is fitted between each fuel tank and the fuel selector valve (C).

Fuel feed is through two electric pumps (E). Each pump has a parallel installed check valve (NRV).

An inline fuel filter (F) is fitted between the fuel pump assembly (E) valve and the engine (G).

A fuel pressure transducer (H) is connected between filter (F) and the engine (G). The signal output of this transducer is connected to the EFIS / iBOX via the RDAC unit.

Surplus fuel returns from the engine (G) to the tanks (A, B) via a fuel return line. The fuel return line splits at the fuel selector (C) to return fuel to the upper inboard section of the tank (A, B) in use.

Fuel drain valves are located under the inner leading edge section of each wing, just forward of the main spar.

Each fuel tank (A, B) is equipped with an individual float sensor. Fuel level indicators for each tank appear on the EFIS display.

**912 ULS ENGINE (SLING LSA):**

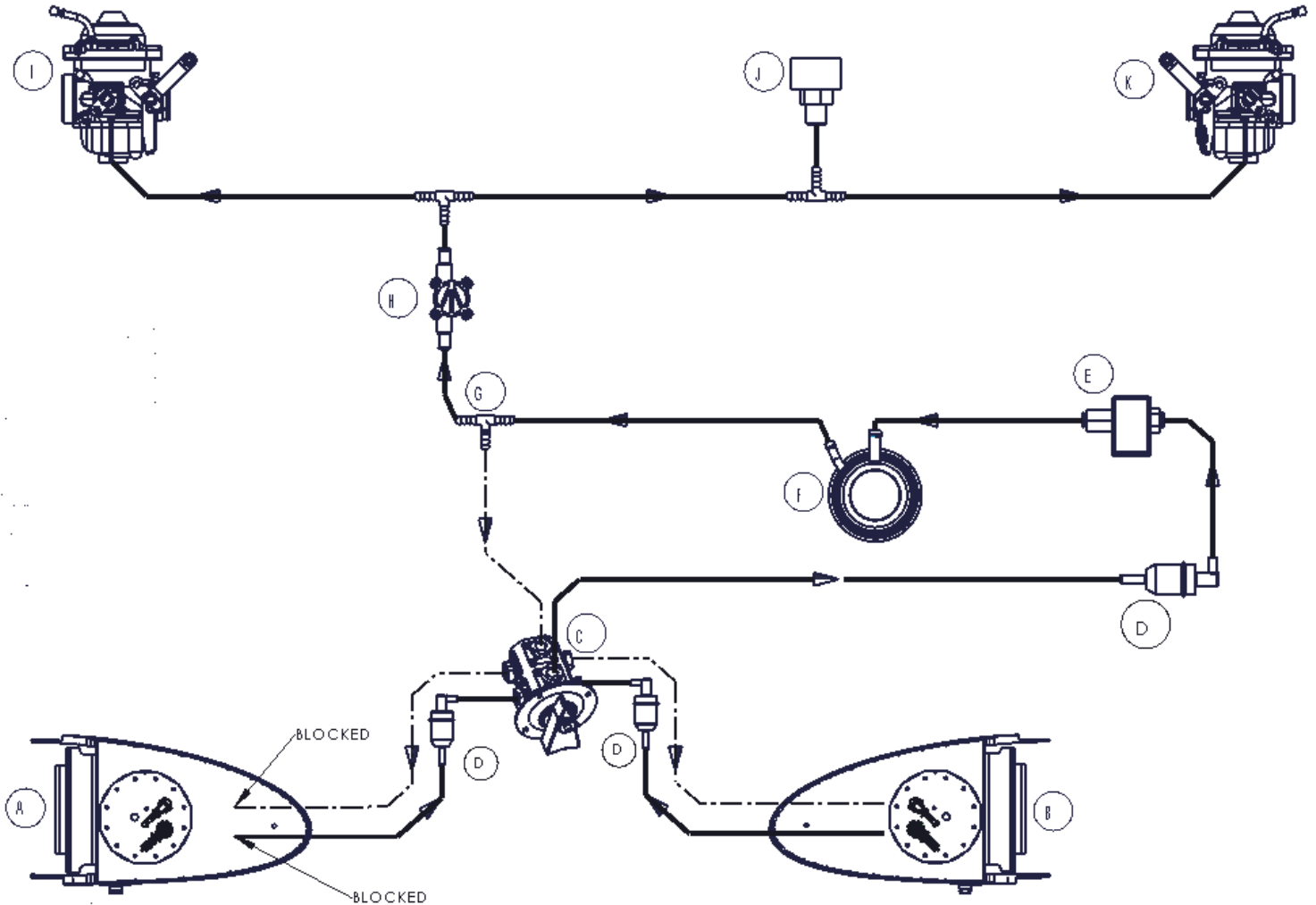

A	Port (left) fuel tank (blocked off)	G	Barbed T-piece
B	Starboard (right) fuel tank	H	Fuel flow sensor
C	Fuel selector (OFF, ON, OFF)	I	Port (left) carburettor
D	Fuel filter (90° bend)	J	Fuel pressure sensor
E	Electric fuel pump	K	Starboard (right) carburettor
F	Mechanical fuel pump		

Figure 57: Fuel system (912 ULS - SLING LSA)

Refer to Figure 57. The aircraft is equipped with two aluminium fuel tanks (A, B) within the wing leading edges, accessible for inspection through dedicated panels. In the Sling LSA the port (left) tank fuel pick-up and return are disconnected and the piping blanked off, thus rendering the port tank unusable.

The fuel outlet for tank B is located at the lowest point of the inboard sidewall of the tank. A finger strainer is fitted to the tank fuel pick-up.

A fuel line from tank B feeds into a fuel selector valve (C), which is mounted on the lower centre instrument panel in the cockpit.

Fuel feed is through two series connected pumps, a main mechanical pump (F) and an auxiliary electrical pump (E) (activated by a switch on the instrument panel).

An inline mesh fuel filter (D) is fitted between each fuel tank and the fuel selector valve (C).

An inline mesh fuel filter (D) is fitted between the fuel selector valve and the electrical fuel pump.

The main fuel feed from the fuel pumps enters a fuel flow sensor (H), whereafter it splits into two separate branches, one for each carburettor. The fuel flow sensor (H) is connected to the EFIS / iBOX via the RDAC unit.

A fuel pressure transducer (J) is connected to one fuel pipe branch and is connected to the EFIS / iBOX via the RDAC unit.

Surplus fuel returns from the outlet of the mechanical pump (F) / inlet of the fuel flow sensor (H) to the tanks B via a fuel return line.

Fuel drain valves are located under the inner leading edge section of each wing, just forward of the main spar.

Each fuel tank (A, B) is equipped with an individual float sensor. A fuel level indicators for tank B appears on the EFIS display.

912 iS ENGINE (SLING LSA):

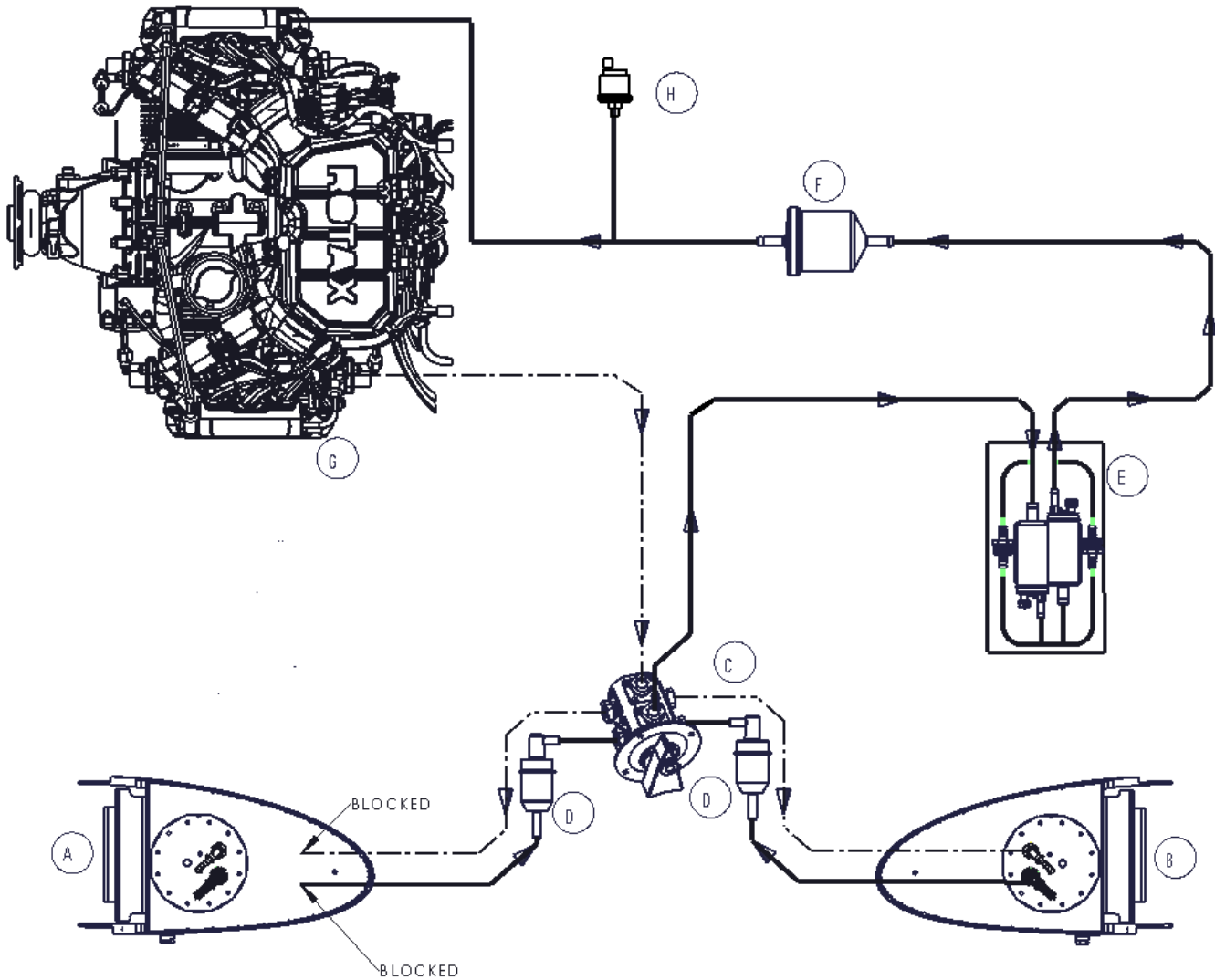

A	Port (left) fuel tank (Blocked off)	F	Fuel filter
B	Starboard (right) fuel tank	G	912 iS engine
C	Fuel selector (OFF, ON, OFF)	H	Fuel pressure transducer
D	Fuel filter (90° bend)		
E	Fuel pump assembly		

Figure 58: Fuel system (912 iS - SLING LSA)

Refer to Figure 58. The aircraft is equipped with two aluminium fuel tanks (A, B) within the wing leading edges, accessible for inspection through dedicated panels. In the Sling LSA the port (left) tank fuel pick-up and return are disconnected and the piping blanked off, thus rendering the port tank unusable.

The fuel outlet for tank B is located at the lowest point of the inboard sidewall of the tank). A finger strainer is fitted to the tank fuel pick-up.

A fuel line from tank B feeds into a fuel selector valve (C), which is mounted on the lower centre instrument panel in the cockpit.

An inline mesh fuel filter (D) is fitted between each fuel tank and the fuel selector valve (C).

Fuel feed is through two electric pumps (E). Each pump has a parallel installed check valve (NRV).

An inline fuel filter (F) is fitted between the fuel pump assembly (E) valve and the engine (G).

A fuel pressure transducer (H) is connected between filter (F) and the engine (G). The signal output of this transducer is connected to the EFIS / iBOX via the RDAC unit.

Surplus fuel returns from the engine (G) to tanks B via a fuel return line..

Fuel drain valves are located under the inner leading edge section of each wing, just forward of the main spar.

Each fuel tank (A, B) is equipped with an individual float sensor. A fuel level indicator for tank B appears on the EFIS display.

**6.2 FUEL FILTER REPLACEMENT**

**6.2.1 INSIDE CABIN (912 ULS, 912 IS, 914 UL)**

TOOLS / EQUIPMENT REQUIRED		
ITEM	QUANTITY	NOTES
1	Flat screwdriver.	1
2	2 mm Allen key.	1
<p>The above list is not necessarily a complete list of all required tools and equipment needed. A calibrated torque wrench (with adequate range) and the correct size (as implied by the above tool list) accessories (sockets etc.) are implied for torquing bolts / nuts, if applicable. Refer to paragraph 1.5 for torque values.</p>		
CONSUMABLE MATERIAL REQUIRED		
ITEM	QUANTITY	NOTES
1	Loctite 222.	As needed.
<p>The above list is not necessarily a complete list of all material needed. Refer to the Sling 2 construction manual.</p>		
AUTHORISED PERSONNEL		
<p>Any person performing maintenance of any kind on the aircraft or any component thereof must do so in accordance with national legislation. This is the responsibility of the aircraft owner and any person who is to perform any maintenance on the aircraft.</p>		

**WARNING**  
**SPILLED FUEL CREATES A SAFETY HAZARD. CLEAN UP SPILLED FUEL BEFORE CONTINUING WITH WORK.**

## PROCEDURE

Retain any bolts, clamps, spacers, screws and washers (with the exception of lock-washers) for reassembly.

1. Fuel selector to OFF position.
2. Drain the fuel from the wing tank(s) if necessary.
3. Remove the central console side panel to gain access to the fuel filters.
4. Loosen the clamps (1) retaining the fuel pipes (2) to the fuel filters (3) and move the clamps back along the fuel lines. Remove tie wraps as required to ease the work.

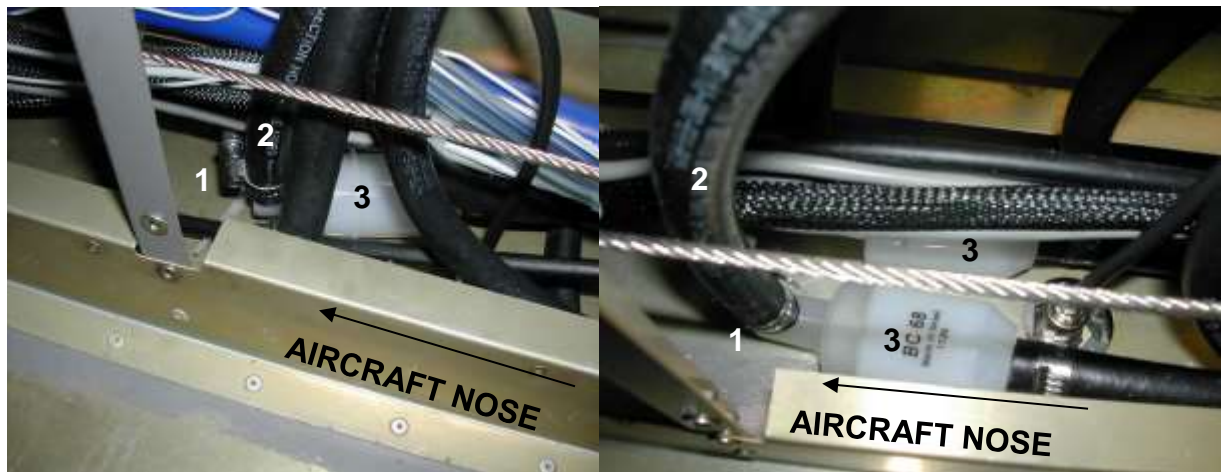

5. Disconnect the filters from the fuel lines and drain any remaining fuel in the lines into a container. Replace the filters. Note that the fuel filters are installed with the 90° elbow facing the nose of the aircraft.
6. Tighten the clamps sufficiently. Do not over tighten, as this may cause damage to the fuel lines. Tie wrap the fuel lines as required, such that the fuel pipes are clear from chaffing against the rudder cables. Do not tighten tie wraps to such an extent that the cross sectional shape of the fuel pipes are distorted.
7. Before flight do an engine ground run and verify correct operation of the fuel system.
8. Inspect for leaks.
9. Apply thread locking sealant to the screws and replace the centre console side panels.

**6.2.2 FIREWALL FORWARD (912 IS)**

TOOLS / EQUIPMENT REQUIRED			
ITEM		QUANTITY	NOTES
1	Side cutter.	1	
2	Locking pliers.	1	Installation only.
3	Hacksaw or Dremel tool. Refer to paragraph 5.1.	1	Removal only.
4	Front pincer pliers.	1	To crimp two-ear pipe clamps. Installation.
<p>The above list is not necessarily a complete list of all required tools and equipment needed. A calibrated torque wrench (with adequate range) and the correct size (as implied by the above tool list) accessories (sockets etc.) are implied for torquing bolts / nuts, if applicable. Refer to paragraph 1.5 for torque values.</p>			
CONSUMABLE MATERIAL REQUIRED			
ITEM		QUANTITY	NOTES
1	Two-ear clamps (15 mm).	2	
2	Safety wire.	As needed	
<p>The above list is not necessarily a complete list of all material needed. Refer to the Sling 2 construction manual.</p>			
AUTHORISED PERSONNEL			
<p>Any person performing maintenance of any kind on the aircraft or any component thereof must do so in accordance with national legislation. This is the responsibility of the aircraft owner and any person who is to perform any maintenance on the aircraft.</p>			

**WARNING**  
**MASTER / IGNITION SWITCHES OFF.**

**WARNING**  
**ALLOW THE ENGINE AND APPLICABLE COMPONENTS TO COOL COMPLETELY BEFORE PERFORMING ANY WORK OR INSPECTION IN THE ENGINE COMPARTMENT. HOT ENGINE COMPONENTS CAN CAUSE SERIOUS BURNS AND CAN IGNITE SPILLED FLUID / VAPOUR.**



## PROCEDURE

Retain any bolts, clamps, spacers, screws and washers (with the exception of lock-washers) for reassembly.

1. Fuel selector to OFF position.
2. Remove the engine cowlings (refer to paragraph 5.1.1).
3. Cut the safety wire (1), pull back the fire resistant sleeving (2) to reveal the two-ear clamps (3) securing the filter (4) to the fuel pipes.
4. Remove the two-ear clamps (refer to paragraph 5.1).

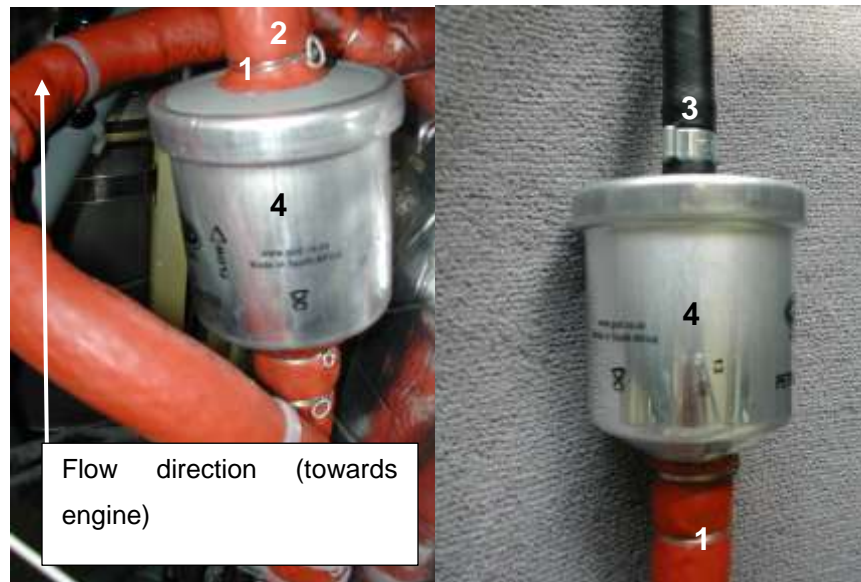

5. Disconnect the filter from the fuel lines.
6. Slip a two-ear clamp over each fuel pipe.
7. Replace the filter (ensure that the filter is fitted in the correct directional / flow sense), secure the fuel pipes to the filter with the two-ear clamps, move the fire resistant sleeving into place and secure with safety wire.
8. Before flight do an engine ground run and verify correct operation of the fuel system.
9. Inspect for leaks.
10. Replace the engine cowlings (refer to paragraph 5.1.1).

### 6.2.3 FIREWALL FORWARD (912 ULS)

TOOLS / EQUIPMENT REQUIRED			
ITEM		QUANTITY	NOTES
1	Side cutter.	1	Removal only.
2	Locking pliers.	1	Installation only.
The above list is not necessarily a complete list of all required tools and equipment needed. A calibrated torque wrench (with adequate range) and the correct size (as implied by the above tool list) accessories (sockets etc.) are implied for torquing bolts / nuts, if applicable. Refer to paragraph 1.5 for torque values.			
CONSUMABLE MATERIAL REQUIRED			
ITEM		QUANTITY	NOTES
1	Worm drive clamps	2	If in need of replacement.
2	Safety wire.	As needed	
The above list is not necessarily a complete list of all material needed. Refer to the Sling 2 construction manual.			
AUTHORISED PERSONNEL			
Any person performing maintenance of any kind on the aircraft or any component thereof must do so in accordance with national legislation. This is the responsibility of the aircraft owner and any person who is to perform any maintenance on the aircraft.			

The procedure and considerations are generally the same as that for the 912 iS installation (refer to paragraph 6.2.2), with the following exceptions:

- A different filter is used (the same 90-degree plastic filter as used inside the cabin (refer to paragraph 6.2.1 and 1.20)).
- The filter is covered by fire resistant sleeving secured in place by safety wire. Cut the safety wire and remove the fire resistant sleeving to gain access to the filter and clamps.
- The filter is retained to the fuel hoses by worm drive clamps. Replace the clamps if required.
- Ensure the filter is fitted correctly with regard to flow direction.
- Before flight do an engine ground run and verify correct operation of the fuel system.
- Inspect for leaks.

### 6.3 FUEL SELECTOR UNIT REMOVAL / INSTALLATION

TOOLS / EQUIPMENT REQUIRED			
ITEM	QUANTITY	NOTES	
1	2.5 mm Allen key (short nosed).	1	
2	2 mm Allen key	1	
3	Front pincer pliers.	1	To crimp two-ear pipe clamps. Installation only.
4	Hacksaw or Dremel tool.	1	Refer to paragraph 5.1. Removal only.
<p>The above list is not necessarily a complete list of all required tools and equipment needed. A calibrated torque wrench (with adequate range) and the correct size (as implied by the above tool list) accessories (sockets etc.) are implied for torquing bolts / nuts, if applicable. Refer to paragraph 1.5 for torque values.</p>			
CONSUMABLE MATERIAL REQUIRED			
ITEM	QUANTITY	NOTES	
1	Loctite 222.	As needed.	Inspection panel screws and four selector unit retaining screws.
2	Two-ear pipe clamps (15 mm).	4 (914 UL) 3 (912 ULS / 912 iS)	Sling 2.
3	Two-ear pipe clamps (13 mm).	2 (914 UL) 3 (912 ULS / 912 iS)	
4	Two-ear pipe clamps (15 mm).	2 (912 ULS / 912 iS)	Sling LSA
5	Two-ear pipe clamps (13 mm).	2 (912 ULS / 912 iS)	
<p>The above list is not necessarily a complete list of all material needed. Refer to the Sling 2 construction manual.</p>			
AUTHORISED PERSONNEL			
<p>Any person performing maintenance of any kind on the aircraft or any component thereof must do so in accordance with national legislation. This is the responsibility of the aircraft owner and any person who is to perform any maintenance on the aircraft.</p>			

**WARNING**  
**SPILLED FUEL CREATES A SAFETY HAZARD. CLEAN UP SPILLED FUEL BEFORE CONTINUING WITH WORK.**

## PROCEDURE (REMOVAL)

Retain any bolts, clamps, spacers, screws and washers (with the exception of lock-washers) for reassembly.

1. Access is gained to the unit from behind and below the instrument panel. Removing the centre console side inspection panel might ease access.
2. Pull / raise the safety button (1) to reveal the screw (2) retaining the selector lever (3) to the selector valve unit. Loosen the screw and remove / slide off the lever.



3. Loosen the four button head screws (4) retaining the plate (5) to the selector unit. Push the unit towards the nose of the aircraft to expose (fuel pipe flexibility should allow this) and remove the fuel pipes from the unit's fittings, by removing the two-ear clamps (refer to paragraph 5.1) retaining the pipes to the selector unit. Alternatively gain access to the fittings via the centre console side inspection panels.
4. Blank off the fuel pipes if to be left unconnected for an extended time.

## PROCEDURE (INSTALLATION)

1. Reverse the above procedure (removal), paying close attention to the following:
  - Inspect all bolts and / or screws for damage. Replace if necessary.
  - Apply thread locking sealant to the selector unit retaining screws before fitting. Do not over tighten the button head screws.
  - The fuel selector lever is keyed to the fuel selector unit shaft.
  - The faceplate only lines up one way with the holes in the selector unit, aiding the correct orientation of the unit on installation.
  - Refer to Figure 60 and Figure 61 for selector port allocation and fuel hose fitting orientation(s).
2. Before flight, perform an engine ground run and verify correct operation of the selector unit / correct feed from both fuel tanks.
3. After the engine ground run inspect for leaks. Inspect for security of attachment.
4. Apply thread locking sealant to the inspection panel screws before fitting. Close the inspection panels, if applicable.

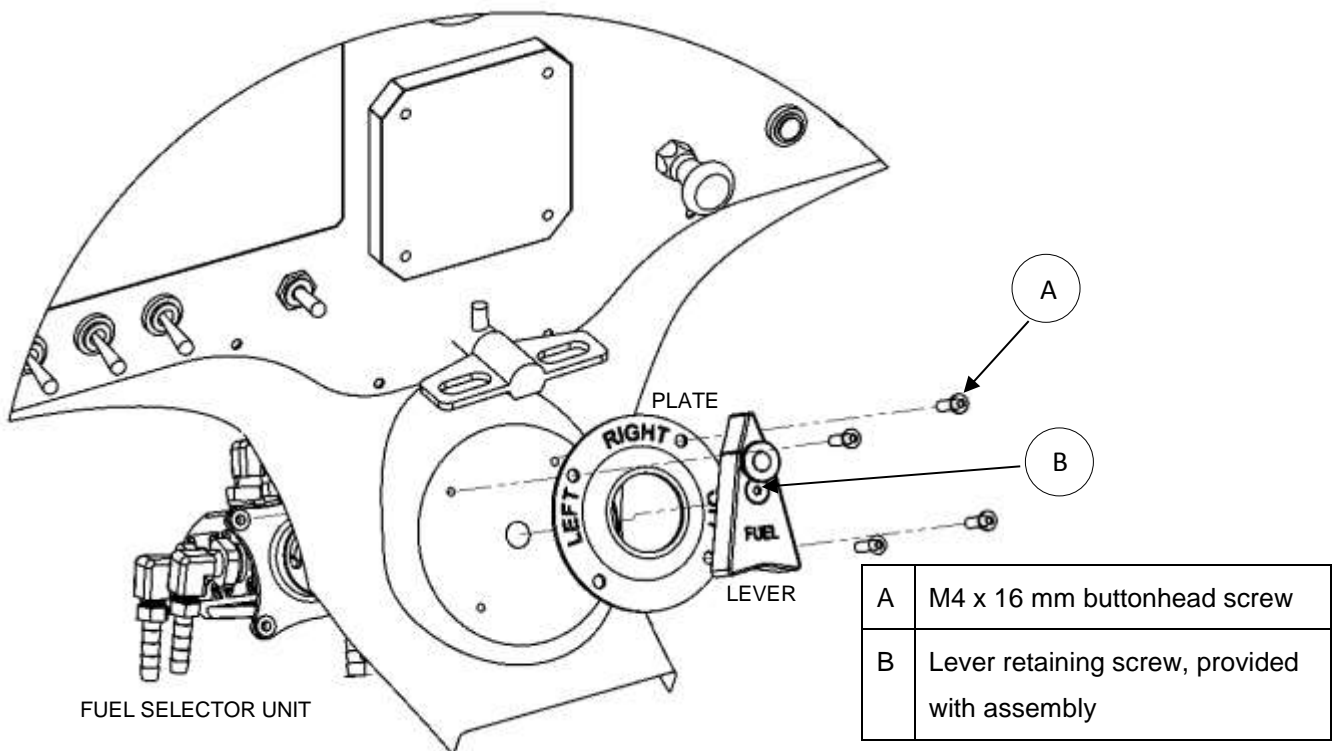

Figure 59: Fuel selector unit installation.

## 6.4 FUEL SELECTOR UNIT ASSEMBLY / DISASSEMBLY

TOOLS / EQUIPMENT REQUIRED			
ITEM		QUANTITY	NOTES
1	½ inch Spanner.	1	Fuel hose fittings.
2	7/16 Spanner.	1	Fuel hose fittings.
The above list is not necessarily a complete list of all required tools and equipment needed. A calibrated torque wrench (with adequate range) and the correct size (as implied by the above tool list) accessories (sockets etc.) are implied for torquing bolts / nuts, if applicable. Refer to paragraph 1.5 for torque values.			
CONSUMABLE MATERIAL REQUIRED			
ITEM		QUANTITY	NOTES
1	Loctite 577	As needed.	Fuel hose fitting threads.
The above list is not necessarily a complete list of all material needed. Refer to the Sling 2 construction manual.			
AUTHORISED PERSONNEL			
Any person performing maintenance of any kind on the aircraft or any component thereof must do so in accordance with national legislation. This is the responsibility of the aircraft owner and any person who is to perform any maintenance on the aircraft.			

### ASSEMBLY / DISASSEMBLY

1. Fitting (1) is screwed into the fuel selector unit body (2). Fitting (3) (for 8 mm or 6 mm inner diameter fuel pipe, depending on engine installation (refer to Figure 60)) is screwed into fitting (1). Apply thread locking sealant to fitting (1) and (3) threads before fitment.



2. Align the fuel hose fittings for easy fit and alignment with the fuel hoses (refer to Figure 61).
3. Reverse the above to disassemble the fuel selector unit.

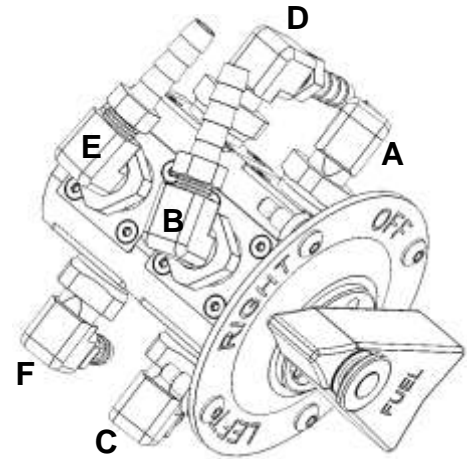
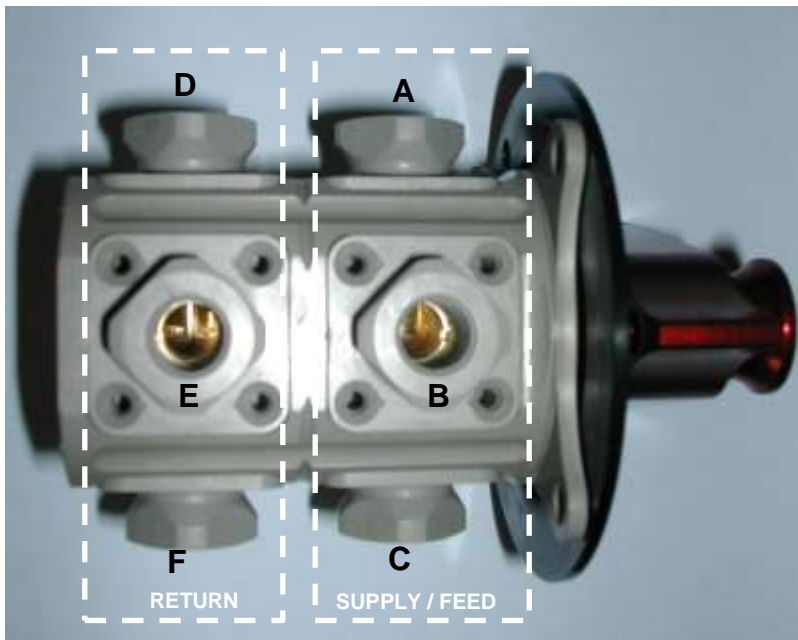

The above schematic does not show the correct alignment for the fuel fittings. It is intended for port identification only.

PORT	FUEL PIPE INSIDE DIAMETER			ALLOCATION
	914 UL	912 ULS / 912 iS		
		SLING 2	SLING LSA	
A	8 mm	8 mm	8 mm	From starboard tank (feed)
B	8 mm	8 mm	8 mm	To engine / pumps (feed)
C	8 mm	8 mm	Blanked off	From port tank (feed)
D	6 mm	6 mm	6 mm	To starboard tank (return)
E	8 mm	6 mm	6 mm	From engine (return)
F	6 mm	6 mm	Blanked off	To port tank (return)

Figure 60: Fuel selector port allocation and fitting orientation.

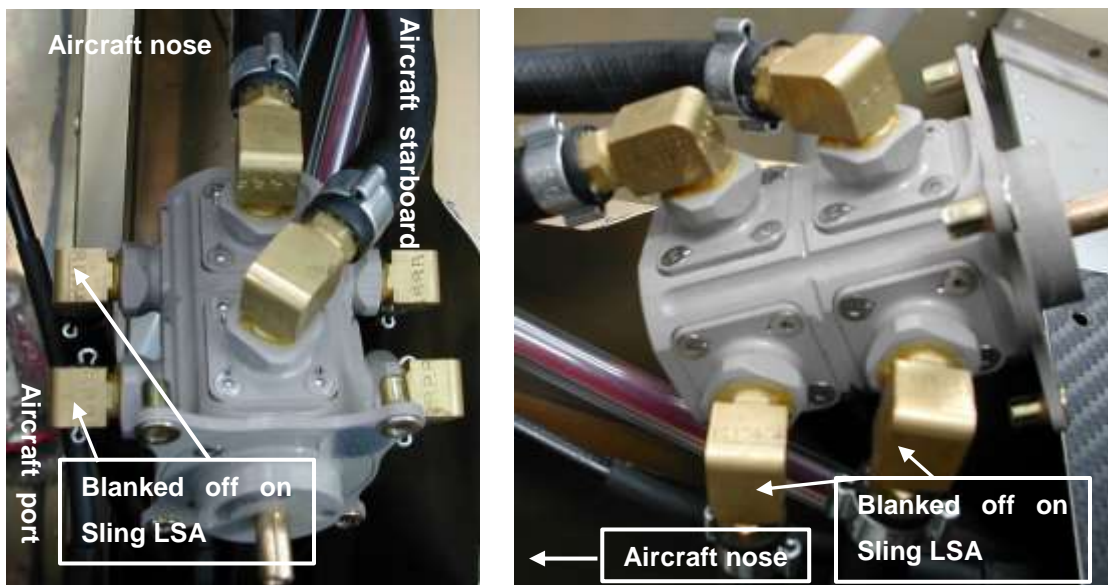

Figure 61: Fuel selector fuel fitting alignment.

**6.5 FUEL PUMP ASSEMBLY REMOVAL / INSTALLATION (914 UL)**

TOOLS / EQUIPMENT REQUIRED			
	ITEM	QUANTIT Y	NOTES
1	Flat screwdriver and side cutter.	1 Each	
2	Locking pliers.	1	Installation.
3	2.5 mm Allen key / hex drive.	1	
4	7 mm Spanner / hex drive, 8 mm spanner / hex drive.	1 Each	
5	Hacksaw or Dremel tool / front pincer pliers.	1 Each	Two-ear clamp removal / installation.
<p>The above list is not necessarily a complete list of all required tools and equipment needed. A calibrated torque wrench (with adequate range) and the correct size (as implied by the above tool list) accessories (sockets etc.) are implied for torquing bolts / nuts, if applicable. Refer to paragraph 1.5 for torque values.</p>			
CONSUMABLE MATERIAL REQUIRED			
	ITEM	QUANTITY	NOTES
1	Safety wire and tie wraps, 8 mm x 12 mm x 5 mm seal draft rubber strip.	As needed.	
2	Two-ear clamps. (15 mm)	2	
3	Tie wraps, clear tubing.	As needed.	
<p>The above list is not necessarily a complete list of all material needed. Refer to the Sling 2 construction manual.</p>			
AUTHORISED PERSONNEL			
<p>Any person performing maintenance of any kind on the aircraft or any component thereof must do so in accordance with national legislation. This is the responsibility of the aircraft owner and any person who is to perform any maintenance on the aircraft.</p>			

**WARNING**  
**MASTER / IGNITION SWITCHES OFF.**

**WARNING**

**ALLOW THE ENGINE AND APPLICABLE COMPONENTS TO COOL COMPLETELY BEFORE PERFORMING ANY WORK OR INSPECTION IN THE ENGINE COMPARTMENT. HOT ENGINE COMPONENTS CAN CAUSE SERIOUS BURNS AND CAN IGNITE SPILLED FLUID / VAPOUR.**

**WARNING**

**SPILLED FUEL CREATES A SAFETY HAZARD. CLEAN UP SPILLED FUEL BEFORE CONTINUING WITH WORK.**



## PROCEDURE (REMOVAL)

Retain any bolts, nuts (except lock-nuts) spacers, screws and washers (with the exception of lock-washers) for reassembly.

1. Fuel selector in OFF position.
2. Remove the cowlings (refer to paragraph 5.1.1).
3. Undo the button head screws (1) retaining the fuel pump assembly cover (2), slide the cover downwards and remove.
4. Remove the tie wraps (3) securing capacitors (4) (part of the electrical wiring) to the assembly.



- Disconnect the fuel hoses (5) from the assembly, by removing the safety wire, pulling the fire resistant sleeving back and removing the two-ear clamps (refer to paragraph 15.1). Pull the fuel hoses from the pump frame connections (6). Drain excess fuel in the lines into a container. Blank off any fuel lines to be left open for an extended time to avoid drip, spillage and contamination.

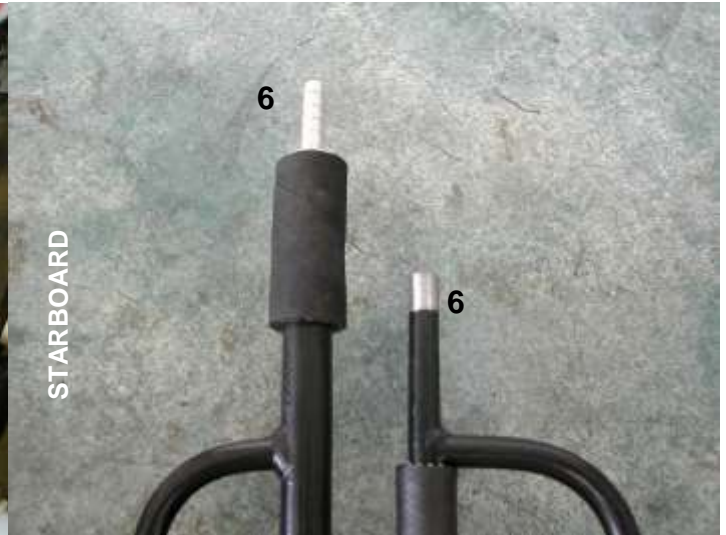

- Disconnect the electrical wiring (7) from the connectors (8) on the two fuel pumps by loosening the lock-nuts (9) securing the lugs (10).

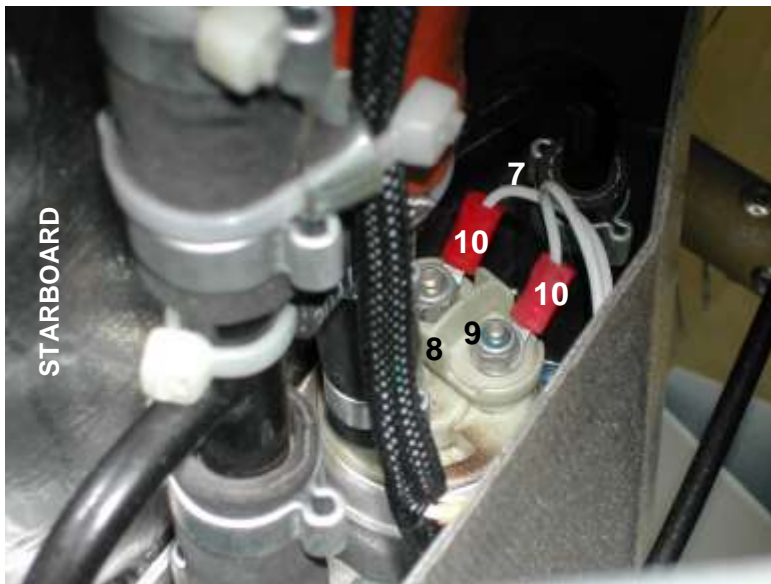

From fuel selector      To engine

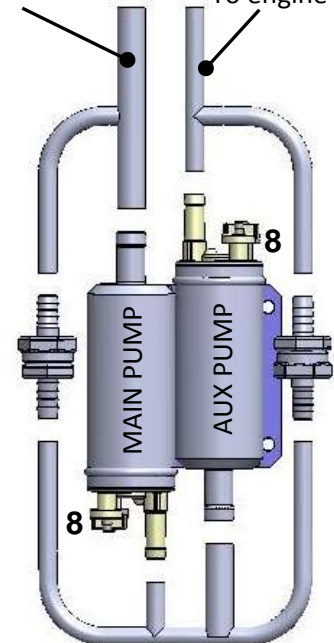

7. Undo the two clamps (11) retaining the pump assembly to the firewall bracket and remove the assembly.



## PROCEDURE (INSTALLATION)

1. Reverse the above procedure (removal), paying close attention to the following:

- Do not reuse lock-nuts. Fit new.
- Inspect all bolts, nuts and screws for damage. Replace if necessary.
- Do not tighten the cover button head screws excessively.
- Ensure that the wires marked GND is connected to the terminals marked (-) on the fuel pump connector blocks and that the wires marked MAIN PUMP + and AUX PUMP + are connected to the terminal marked (+) on the respective fuel pump connector blocks. Note that the assembly is mounted on the firewall with the MAIN PUMP to starboard and the AUX PUMP to port.

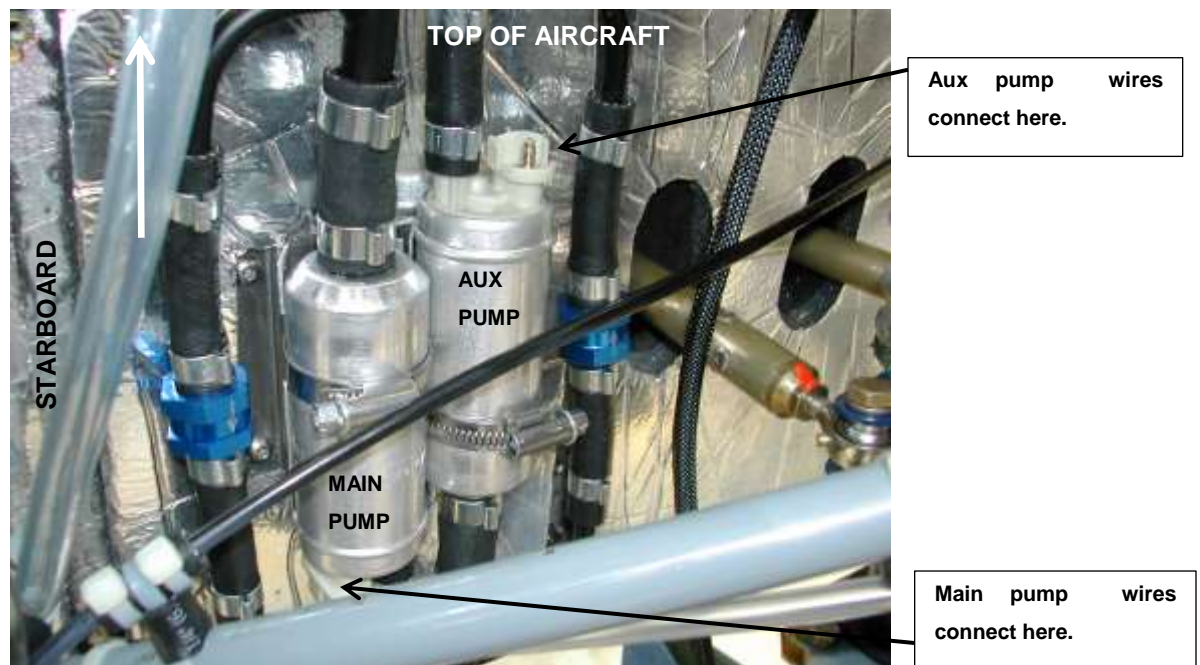

- Fit seal draft rubber strips (1) to the pump assembly bracket (2) before fitting the assembly to the firewall.



2. Before flight, perform an engine ground run and verify correct operation (of the fuel pumps) and correct fuel flow and pressure. After the engine run inspect for any sign of fuel leaking at the pump / pump assembly-to-hose connections.

**6.6 FUEL PUMP REMOVAL / INSTALLATION FROM / IN FUEL PUMP ASSEMBLY (914 UL)**

TOOLS / EQUIPMENT REQUIRED			
ITEM	QUANTITY	NOTES	
1	Front pincer pliers.	1	To crimp two-ear pipe clamps. Installation.
2	Hacksaw or Dremel tool.	1	Refer to paragraph 5.1. Removal.
The above list is not necessarily a complete list of all required tools and equipment needed. A calibrated torque wrench (with adequate range) and the correct size (as implied by the above tool list) accessories (sockets etc.) are implied for torquing bolts / nuts, if applicable. Refer to paragraph 1.5 for torque values.			
CONSUMABLE MATERIAL REQUIRED			
ITEM	QUANTITY	NOTES	
1	Two-ear clamps (22 mm).	2 Per pump.	
2	Two-ear clamps (15 mm).	2 per pump.	
The above list is not necessarily a complete list of all material needed. Refer to the Sling 2 construction manual.			
AUTHORISED PERSONNEL			
Any person performing maintenance of any kind on the aircraft or any component thereof must do so in accordance with national legislation. This is the responsibility of the aircraft owner and any person who is to perform any maintenance on the aircraft.			

**WARNING**  
**SPILLED FUEL CREATES A SAFETY HAZARD. CLEAN UP SPILLED FUEL BEFORE CONTINUING WITH WORK.**

## PROCEDURE (REMOVAL)

1. Remove the fuel pump assembly (refer to paragraph 6.5), if required, else disconnect the applicable pump's electrical wiring (refer to paragraph 6.5).
2. Remove (refer to paragraph 5.1) the two-ear clamps (1) on the rubber hoses (2) connecting the fuel pump to the surrounding pipe framework (3) and remove the pump (4) from the pipe frame.

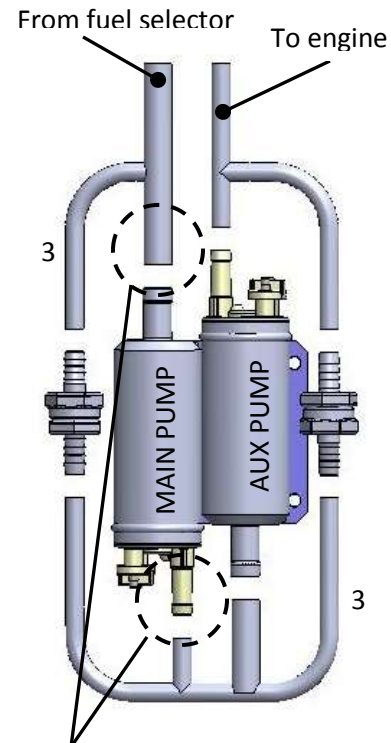

Remove connecting rubber hosing from here to remove pump.

## PROCEDURE (INSTALLATION)

1. Reverse the above procedure (removal) to install a fuel pump into the pipe framework, paying close attention to the following:
  - Inspect the rubber hoses before fitment. Replace if necessary.
2. Inspect for security of attachment (rubber hoses).

## 6.7 FUEL PUMP ASSEMBLY REMOVAL / INSTALLATION (912 IS)

TOOLS / EQUIPMENT REQUIRED			
ITEM		QUANTITY	NOTES
1	Flat screwdriver and side cutter.	1 Each	
2	Locking pliers.	1	Installation.
3	2.5 mm Allen key / hex drive.	1	
The above list is not necessarily a complete list of all required tools and equipment needed. A calibrated torque wrench (with adequate range) and the correct size (as implied by the above tool list) accessories (sockets etc.) are implied for torquing bolts / nuts, if applicable. Refer to paragraph 1.5 for torque values.			
CONSUMABLE MATERIAL REQUIRED			
ITEM		QUANTITY	NOTES
1	Safety wire and tie wraps.	As needed.	
2	Two-ear clamps. (15 mm)	2	
The above list is not necessarily a complete list of all material needed. Refer to the Sling 2 construction manual.			
AUTHORISED PERSONNEL			
Any person performing maintenance of any kind on the aircraft or any component thereof must do so in accordance with national legislation. This is the responsibility of the aircraft owner and any person who is to perform any maintenance on the aircraft.			

The procedure and considerations for removal and installation is generally the same as that described for the 914 UL installation (refer to paragraph 6.5), with the following exceptions:

- The electrical / signal wires are plugged into the pump electrical terminals, instead of being secured via a lock-nut.
- The position of the MAIN PUMP and AUX PUMP are reversed from that of the 914 UL installation.

## 6.8 FUEL PUMP REMOVAL / INSTALLATION FROM / IN FUEL PUMP ASSEMBLY (912 IS)

The procedure and considerations for removal and installation is generally the same as that described for the 914 UL installation (refer to paragraph 6.6).



**6.9 ELECTRIC FUEL PUMP REMOVAL / INSTALLATION (912 ULS)**

TOOLS / EQUIPMENT REQUIRED			
	ITEM	QUANTITY	NOTES
1	½ inch Spanner, 7/16 spanner	1 Each	Fuel pump fittings.
2	Side cutter / electric solder iron.	1 Each	
3	Locking pliers, front pincer pliers	1 Each	Installation.
4	Hacksaw or Dremel tool	1	Removal.
5	2.5 mm Allen key / hex drive.	1	Pump heat shroud screws.

The above list is not necessarily a complete list of all required tools and equipment needed. A calibrated torque wrench (with adequate range) and the correct size (as implied by the above tool list) accessories (sockets etc.) are implied for torquing bolts / nuts, if applicable. Refer to paragraph 1.5 for torque values.

CONSUMABLE MATERIAL REQUIRED			
	ITEM	QUANTITY	NOTES
1	Two-ear clamps. (15 mm)	2	Installation
2	Loctite 577, Loctite 222	As needed.	Fuel pump fittings.
3	Heatshrink / solder / safety wire / tie wraps	As needed.	Fuel pump wires.

The above list is not necessarily a complete list of all material needed. Refer to the Sling 2 construction manual.

AUTHORISED PERSONNEL			
Any person performing maintenance of any kind on the aircraft or any component thereof must do so in accordance with national legislation. This is the responsibility of the aircraft owner and any person who is to perform any maintenance on the aircraft.			

**WARNING**  
**MASTER / IGNITION SWITCHES OFF.**

**WARNING**  
**ALLOW THE ENGINE AND APPLICABLE COMPONENTS TO COOL COMPLETELY BEFORE PERFORMING ANY WORK OR INSPECTION IN THE ENGINE COMPARTMENT. HOT ENGINE COMPONENTS CAN CAUSE SERIOUS BURNS AND CAN IGNITE SPILLED FLUID / VAPOUR.**

**WARNING**  
**SPILLED FUEL CREATES A SAFETY HAZARD. CLEAN UP SPILLED FUEL BEFORE CONTINUING WITH WORK.**

## PROCEDURE (REMOVAL)

Retain any bolts, nuts (except lock-nuts) spacers, screws and washers (with the exception of lock-washers) for reassembly.

1. Fuel selector in OFF position.
2. Remove the cowlings (refer to paragraph 5.1.1) for easier access. Refer to paragraph 4.3 for the location of the electric fuel pump on the firewall.
3. Remove tie wraps as required. Remove the heatshrink (1) from the wires and desolder.
4. Cut the safety wire (2), pull the fire resistant sleeving (3) back and remove (refer to paragraph 5.1) the two ear clamps retaining the fuel hoses to the fuel pump fittings.
5. Undo the fuel pump fittings (4) (refer to Figure 62).and remove.
6. Undo the three bolts / screws (5) retaining the fuel pump heat shroud (6) to the firewall and remove the shroud (pull the wires attached to the pump through the rubber grommet on the pump cover side).
7. Undo the bolts / screws retaining the pump to the firewall and remove the pump.

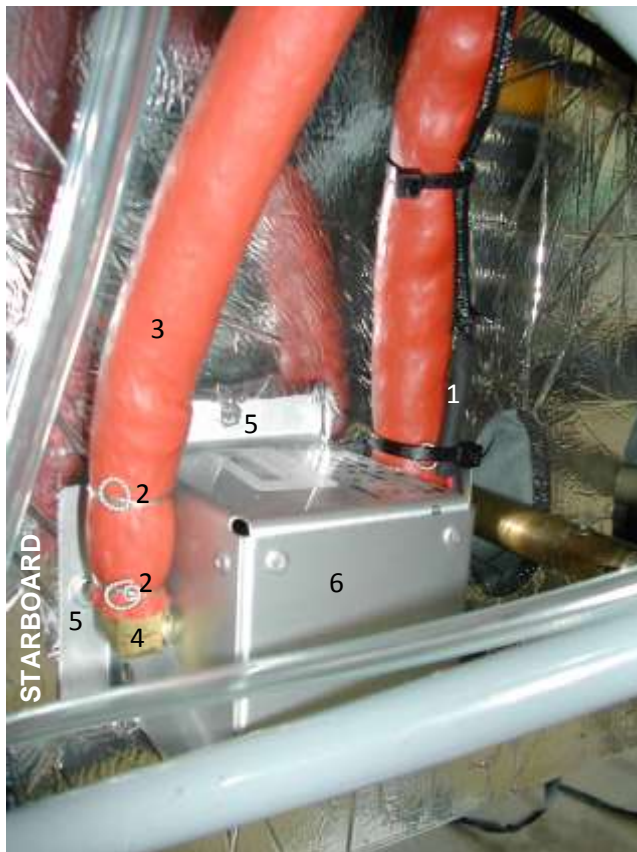

Note: The cover retaining screws (5) (shown in this photograph as hexagonal head bolts ) are button head screws. Refer to Figure 62.

**PROCEDURE (INSTALLATION)**

1. Reverse the above procedure (removal), paying close attention to the following:

- Inspect all bolts / screws for damage. Replace if necessary.
- Apply thread locking sealant to the threads of the fuel pump (hose) fittings, fuel pump mounting bolts and fuel pump heat shroud screws before fitting.
- Refer to paragraph 5.3 with regard to the fitment of the fire resistant sleeving.
- Ensure pump wires are correctly connected, according to the table below:

AIRCRAFT SIDE (LABEL)	PUMP SIDE (COLOUR)
FUEL PUMP GND	Black
FUEL PUMP +	Red

2. Inspect for security of attachment. Test correct operation of pump before flight.

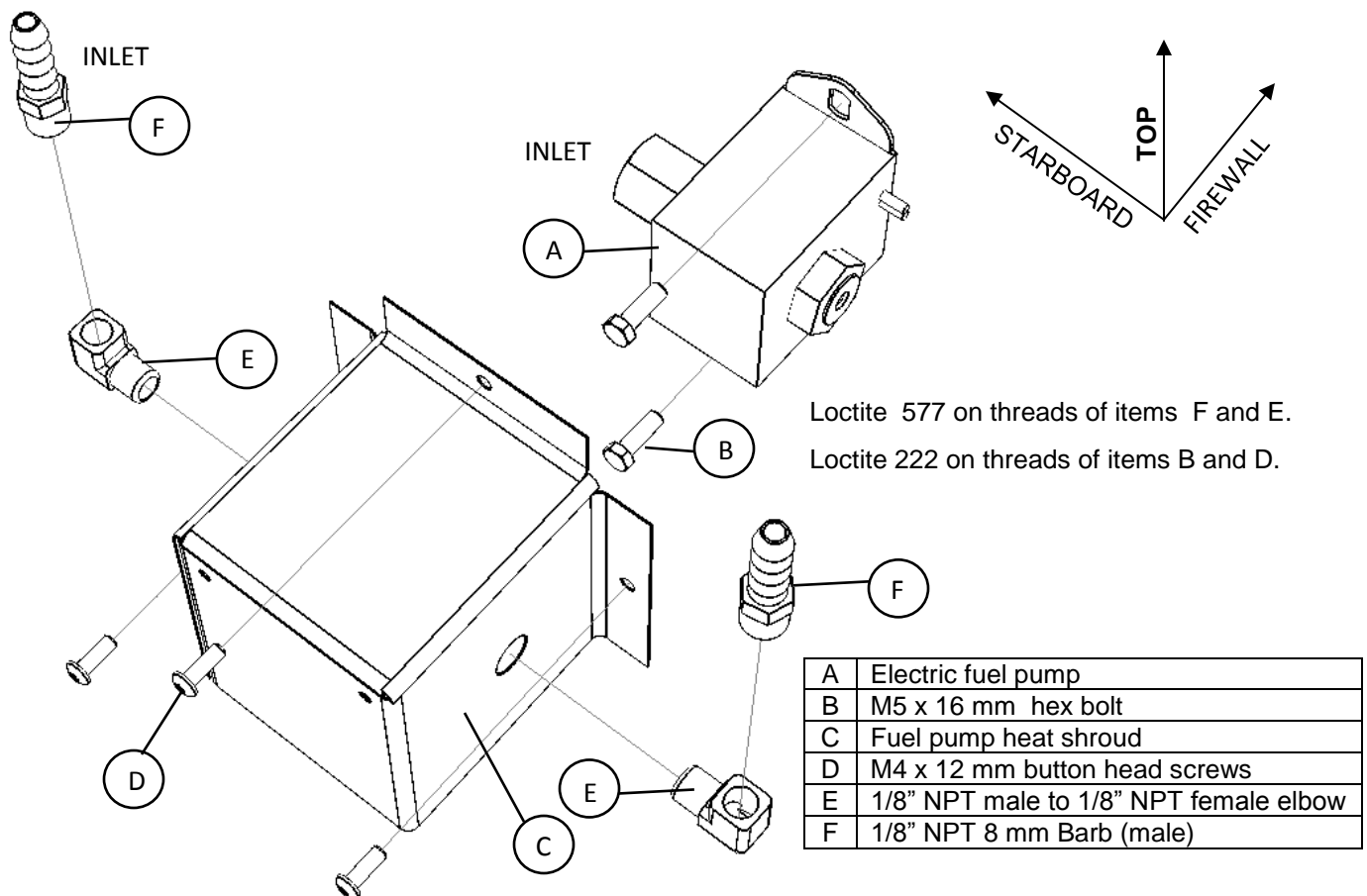

Figure 62: Electric fuel pump fitment / assembly (912 ULS).

## 6.10 FUEL TANK LEAK REPAIR

CONSUMABLE MATERIAL REQUIRED		
ITEM	QUANTITY	NOTES
1	Sealant.	As needed.
Refer to paragraph 1.4.		
The above list is not necessarily a complete list of all material needed. Refer to the Sling 2 construction manual.		
AUTHORISED PERSONNEL		
Any person performing maintenance of any kind on the aircraft or any component thereof must do so in accordance with national legislation. This is the responsibility of the aircraft owner and any person who is to perform any maintenance on the aircraft.		

### PROCEDURE

1. Repairs can only be made if cracks are small.
2. Empty the fuel tank.
3. Repeatedly rinse area with water.
4. Apply sealant according to manufacturer instructions.
5. Verify for no leaks.

### 6.11 FUEL TANK DRAIN REMOVAL / INSTALLATION (DRAINING WING TANK)

A fuel drain is installed for each fuel tank. The drain is located under each wing, near the wing root. The tank can be drained completely by removing (unscrewing) the drain.

TOOLS / EQUIPMENT REQUIRED		
ITEM	QUANTITY	NOTES
1	16 mm Spanner	1
The above list is not necessarily a complete list of all material needed. Refer to the Sling 4 construction manual.		
AUTHORISED PERSONNEL		
Any person performing maintenance of any kind on the aircraft or any component thereof must do so in accordance with national legislation. This is the responsibility of the aircraft owner and any person who is to perform any maintenance on the aircraft.		

**WARNING**

**HAVE THE CORRECT TYPE (FOR FUEL FIRES) FIRE EXTINGUISHER AT HAND.  
CLEAN UP SPILLED FUEL IMMEDIATELY AS IT CREATES A SAFETY HAZARD.  
IT MAY BE EXPEDIENT TO DISCONNECT THE BATTERY GROUND TERMINAL WHILE WORKING ON  
ELECTRICAL EQUIPMENT.**

A fuel drain is installed for each fuel tank. The drain is located under each wing, near the wing root. The tank can be drained completely by removing (unscrewing) the drain.

**PROCEDURE (REMOVAL)**

1. Unscrew the fuel drain from the wing. Do not retain fibre washer.
2. Drain fuel into suitable container.

**PROCEDURE (INSTALLATION)**

1. Observe correct washer placement (refer to Figure 63). Do not reuse fibre washer. Fit new.
2. Fill tank with fuel and inspect for leakage.

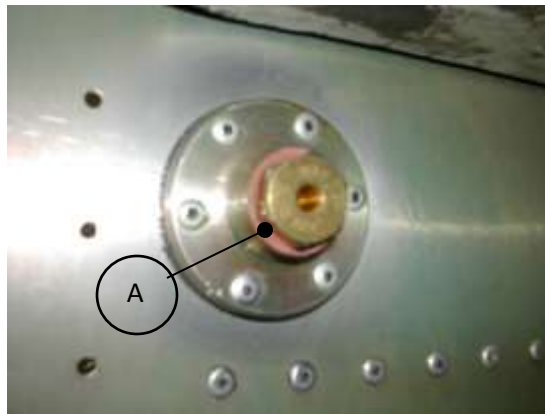

A	M14 fibre washer
---	------------------

Figure 63: Wing tank fuel drain installation.

**6.12 FUEL LEVEL SENDER ASSEMBLY REMOVAL / INSTALLATION (FROM / TO FUEL TANK)**

TOOLS / EQUIPMENT REQUIRED			
ITEM		QUANTITY	NOTES
1	2 mm Allen key		Inspection panel(s).
2	7 mm Spanner	1	Tank cover plate /ender mounting plate/
3	17 mm Spanner.	1	Fuel line couplings.
4	9/16 Spanner.	1	
The above list is not necessarily a complete list of all required tools and equipment needed. A calibrated torque wrench (with adequate range) and the correct size (as implied by the above tool list) accessories (sockets etc.) are implied for torquing bolts / nuts, if applicable. Refer to paragraph 1.5 for torque values.			
CONSUMABLE MATERIAL REQUIRED			
ITEM		QUANTITY	NOTES
1	Loctite 222	As needed	Inspection panel
2	Loctite 577	As needed	Fuel tank outlet / return line couplings.
The above list is not necessarily a complete list of all material needed. Refer to the Sling 4 construction manual.			
AUTHORISED PERSONNEL			
Any person performing maintenance of any kind on the aircraft or any component thereof must do so in accordance with national legislation. This is the responsibility of the aircraft owner and any person who is to perform any maintenance on the aircraft.			

**WARNING**

**HAVE THE CORRECT TYPE (FOR FUEL FIRES) FIRE EXTINGUISHER AT HAND.**

**CLEAN UP SPILLED FUEL IMMEDIATELY AS IT CREATES A SAFETY HAZARD.**

**IT MAY BE EXPEDIENT TO DISCONNECT THE BATTERY GROUND TERMINAL WHILE WORKING ON ELECTRICAL EQUIPMENT.**

The procedure is the same for the left and right tank fuel level sender assembly removal and installation.

### PROCEDURE (REMOVAL)

Retain any bolts, nuts (except lock-nuts) spacers, screws and washers (with the exception of lock-washers) for reassembly.

1. Remove the inspection hatch(es) under the leading edge(s) of the wing(s) to access the fuel tank end rib(s).
2. Drain the fuel tank completely by removing the fuel drain (refer to paragraph 6.11).
3. Loosen the fuel line couplings (1). Move the fuel pipes out of the way.
4. Loosen the nut (2) retaining the signal wire to the fuel level sender terminal stud and remove the signal wire.
5. Undo the button screws (3) retaining the tank cover plate / fuel level sender mounting plate (4).

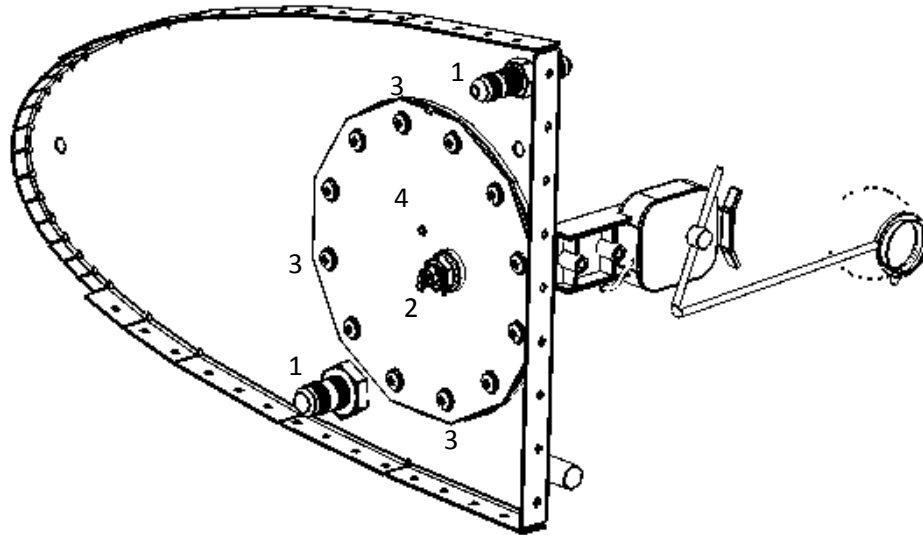

6. Carefully pull the plate / fuel sender assembly away from the wing rib, taking care not to hook the float arm assembly on the hole (in rib) edges.



## PROCEDURE (INSTALLATION)

1. Reverse the above procedure (removal) for installation, paying close attention to the following:
  - Ensure no loose material or tools are left in fuel tank cavity before fitting the fuel level sender / sender mounting plate.
  - Do not re-use the cork gasket or fibre washers. Fit new.
  - The metal washers are fitted between the bolt heads and the fibre washers.
  - Do not re-use nyloc lock-nut on signal wire-to-terminal connection. Fit new.
  - Be careful not to damage the cork gasket during assembly.
  - Observe correct plate orientation and placement of washers (refer to Figure 64). The plate is fitted with the edge with the single notch facing the top of the wing and the edge with two notches facing the rear of the wing.
  - Apply thread locking sealant to the fuel line couplings before fitting and tightening.
2. Inspect for leaks by pressurizing the tank: Ensure that the fuel filler cap is in place and correctly closed. Ensure that the fuel drain is replaced and correctly fitted. Place a hose onto the tank overflow pipe and blow using a hard breath of air. Do not use air pressure from a compressor, since this may cause the tank to burst from over pressurization. Brush soapy water over the gasket area, bolts and fuel line fittings to observe for leaks. Dry / swipe away after inspection.
3. Fill the tank completely and verify for leaks or sweating.
4. Close the inspection hatch under the wing.
5. Run the engine at 4000 rpm for 5 minutes before flying the aircraft.

A	M4 x 16 mm hex head stainless steel bolt
B	M4 thin washer (stainless steel / plated)
C	M4 Fibre washer
D	Sender / sender bracket mounting plate
E	Cork mounting gasket
F	M4 lock-nut (Nyloc) (secures signal wire to terminal stud)

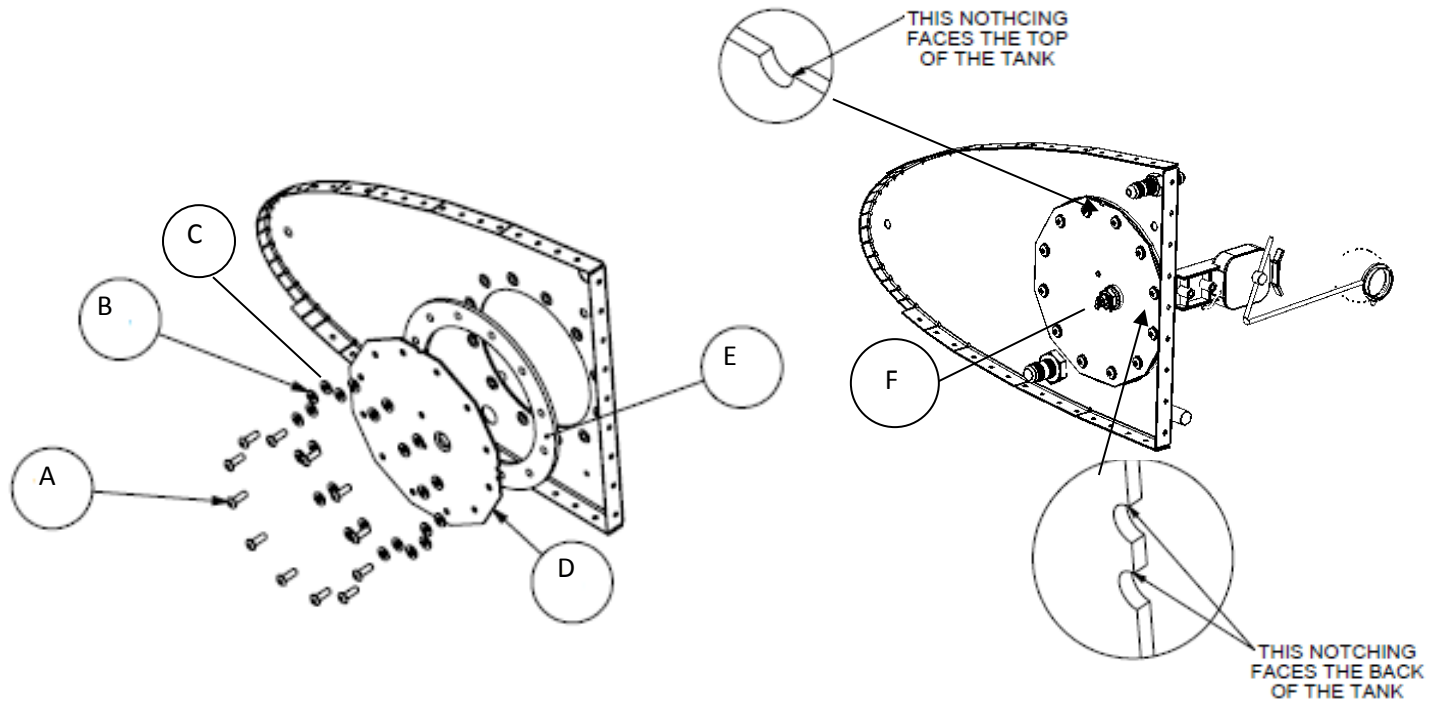

Figure 64: Fuel sender installation into fuel tank.

**6.13 REPLACING FUEL LEVEL SENDER ASSEMBLY SENSOR**

TOOLS / EQUIPMENT REQUIRED			
ITEM		QUANTITY	NOTES
1	7 mm Spanner	1	
2	Side cutter	1	
3	Fibre tipped marking pen (fine point)	1	To mark float arm position
4	Pliers	1	To bend float arm stops on sensor
5	Multimeter	1	
The above list is not necessarily a complete list of all required tools and equipment needed. A calibrated torque wrench (with adequate range) and the correct size (as implied by the above tool list) accessories (sockets etc.) are implied for torquing bolts / nuts, if applicable. Refer to paragraph 1.5 for torque values.			
CONSUMABLE MATERIAL REQUIRED			
ITEM		QUANTITY	NOTES
1	Fuel / fuel tank sealant	As needed	Refer to paragraph 1.4.
2	100 x 2.5 mm tie wrap	1	
The above list is not necessarily a complete list of all material needed. Refer to the Sling 4 construction manual.			
AUTHORISED PERSONNEL			
Any person performing maintenance of any kind on the aircraft or any component thereof must do so in accordance with national legislation. This is the responsibility of the aircraft owner and any person who is to perform any maintenance on the aircraft.			

**WARNING**

**HAVE THE CORRECT TYPE (FOR FUEL FIRES) FIRE EXTINGUISHER AT HAND.**

**CLEAN UP SPILLED FUEL IMMEDIATELY AS IT CREATES A SAFETY HAZARD.**

**IT MAY BE EXPEDIENT TO DISCONNECT THE BATTERY GROUND TERMINAL WHILE WORKING ON ELECTRICAL EQUIPMENT.**

## PROCEDURE (REMOVAL)

The procedure is the same for the left and right tank fuel level sender assembly sensor removal and installation.

Retain any bolts, nuts (except lock-nuts) spacers, screws and washers (with the exception of lock-washers) for reassembly.

1. Remove the fuel level sender from the wing / wing end rib (refer to paragraph 6.12).
2. Undo the nut (1) retaining the signal wire to the terminal stud, cut the tie-wrap and unwind the signal wire from the bracket (2).

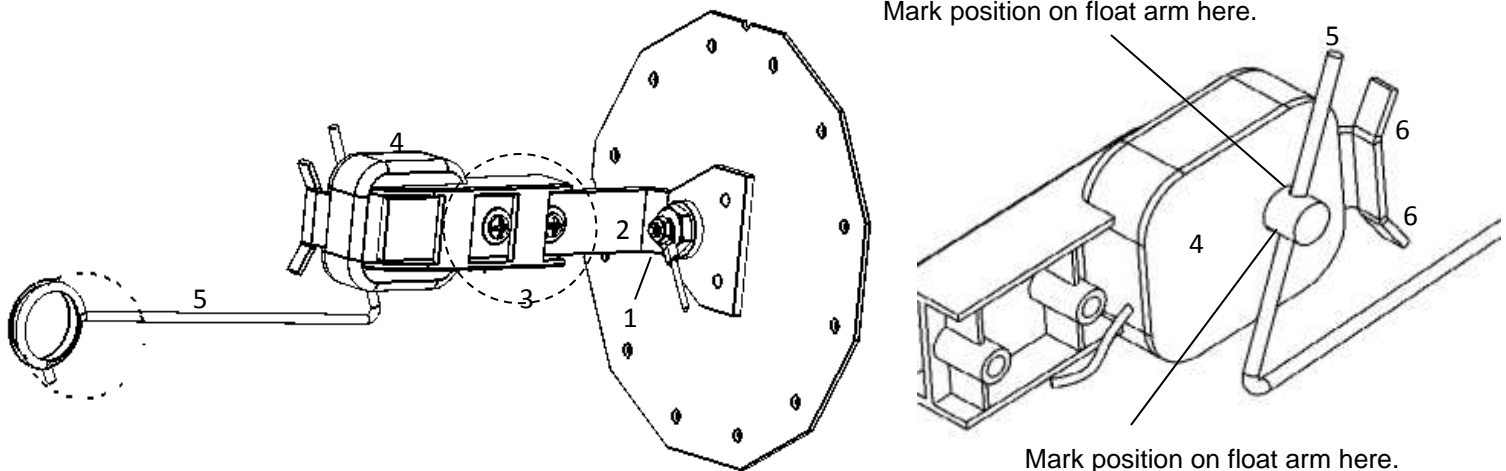

3. Undo the screws (3) retaining the sensor (4) to the bracket (2) and remove the sensor.
4. Mark the position of the float arm (5) where it is secured (by screw) to the sensor.
5. Remove the sealant and undo the screw retaining the float arm (5) to the sensor. Retain the float arm for reassembly onto the replacement sensor.
6. The float arm stops (6) on the replacement sensor must be bent to be identical in position to that on the removed sensor (refer to Figure 54). Retain the removed sensor for reference.

## PROCEDURE (INSTALLATION)

1. Reverse the above procedure (removal) for installation, paying close attention to the following:
  - Observe correct washer placement (refer to Figure 65).
  - The sensor is fitted to the bracket with the spindle pointing away (in opposite direction) from the 90 degree bend / plate / part of the bracket attached to the hexagonal tank cover / sender assembly plate, i.e. spindle will face to rear when level sender assembly is installed in fuel tank. See Figure 65.
  - The float arm is installed onto the sensor spindle so that the (bent) corner will point to the bottom of the fuel tank.
  - (a) The float arm must be fitted to the new sensor with the same point (centre of bent part of arm) on the arm (as was over the centre of the spindle of the removed sensor) over the centre of the sensor spindle (refer to Figure 65). Use the marks made (during disassembly) on the float arm to assist in positioning the float arm before securing it to the sensor spindle.
  - (b) Bend the float arm stops (refer to Figure 65) on the replacement sensor to be identical to that on the sensor which was removed.

**Steps (a) and (b) above are to ensure that the float ball does not touch the tank edges / skin and should be carefully and accurately applied.**

- Wind the signal wire (1) tightly and securely around the bracket (2) and sensor (3) as shown below, without damaging or distorting / stretching it unnecessarily. Route the signal wire as shown and tie wrap (4) the bundle as shown. Cut the excess tie wrap strap off.

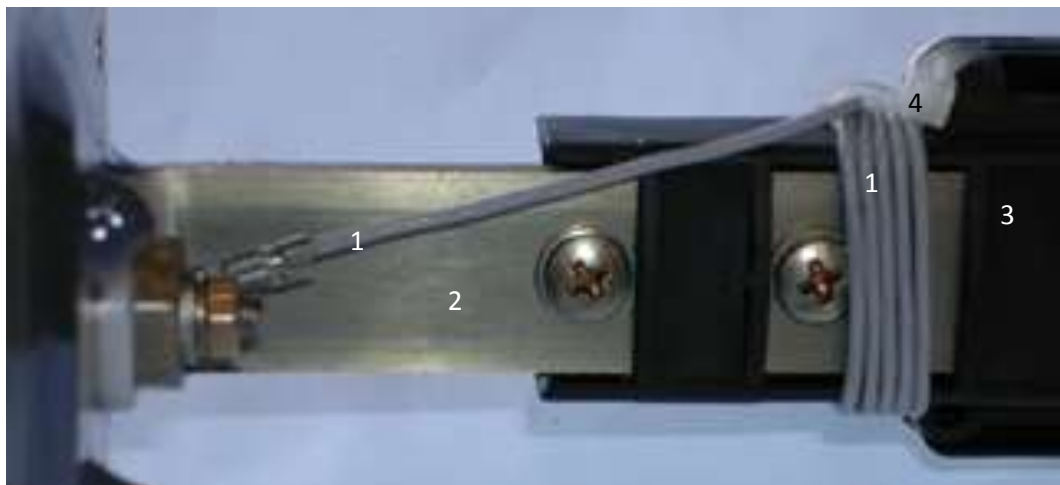

- Do not re-use the lock (split) washer on the signal wire terminal stud. Fit lock washer supplied with sensor.

- Seal / lock (to the sensor spindle) the screw used to secure the float arm to the sensor spindle with fuel / fuel tank sealant. The fuel sealant must be allowed to dry for 48 hours before coming into contact with fuel.
2. Use a multimeter set to measure resistance (set to the 200  $\Omega$  range setting, if available or higher ) to measure the range of the sensor, with the float arm first flush against one stop and then rotated to lie flush against the other stop (refer to Figure 65). The range measured should be between  $> 0 \Omega$  and  $< 200 \Omega$  (approximately 8  $\Omega$  to 192  $\Omega$ ). Measuring an open circuit with the float arm flush against any one of the stops indicates that the sensor wiper has moved of the sensor board pick-up and indicates that the stops are not correctly bent. Bend the stops to exactly match those of the sensor previously removed!
  3. Replace the fuel level sender assembly (refer to paragraph 6.12).
  4. Follow the calibration procedure as outlined in the latest revision of the MGL IEFIS installation manual to calibrate the newly fitted sensor.

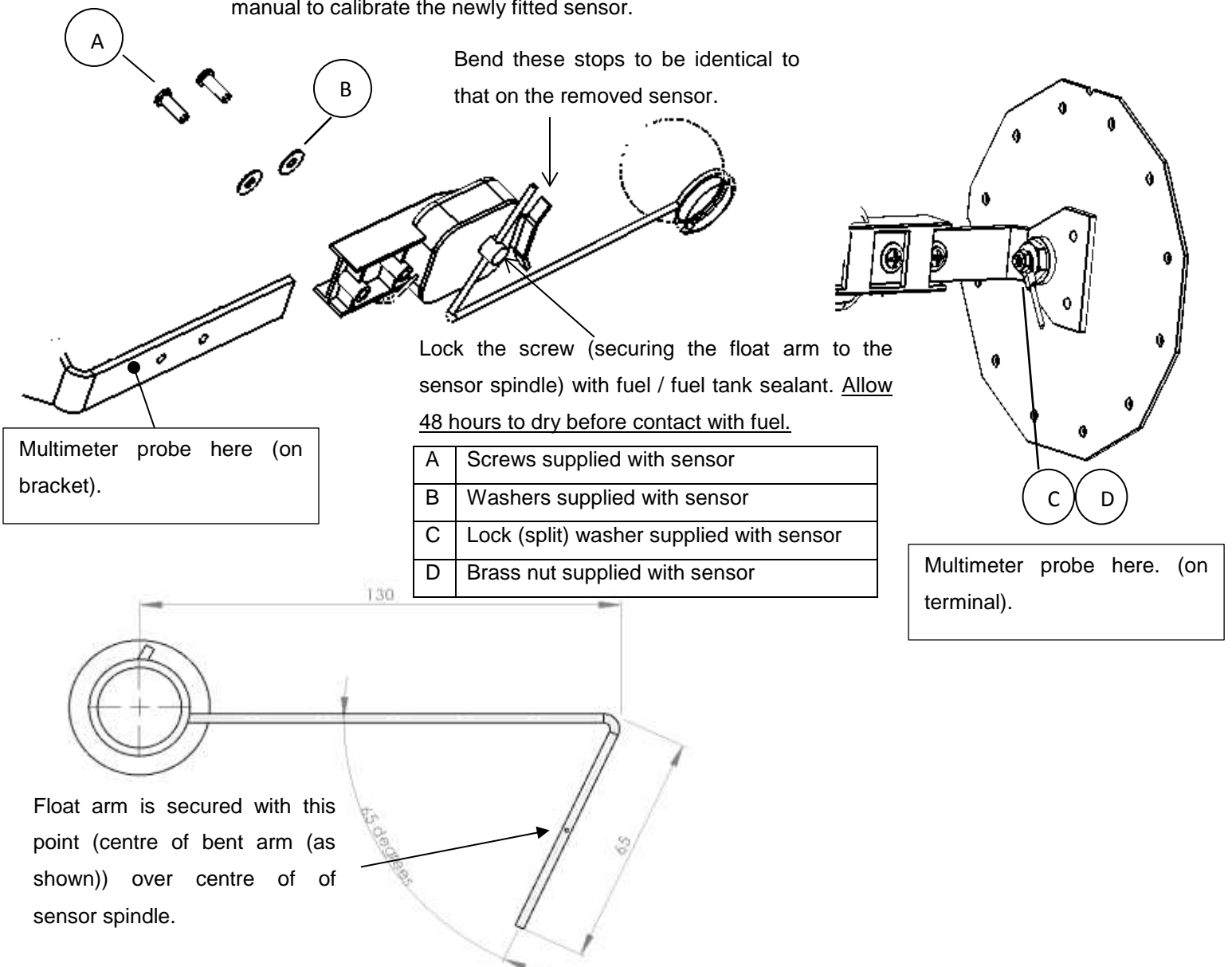

Figure 65: Fuel level sender assembly sensor replacement.

**6.14 FINGER STRAINER (ON FUEL PICK-UP) INSPECTION**

TOOLS / EQUIPMENT REQUIRED			
ITEM		QUANTITY	NOTES
1	Small angled mirror inspection tool	1	
2	Small pencil flashlight	1	
3	Source of compressed air (low pressure)	1	
<p>The above list is not necessarily a complete list of all required tools and equipment needed. A calibrated torque wrench (with adequate range) and the correct size (as implied by the above tool list) accessories (sockets etc.) are implied for torquing bolts / nuts, if applicable. Refer to paragraph 1.5 for torque values.</p>			
AUTHORISED PERSONNEL			
<p>Any person performing maintenance of any kind on the aircraft or any component thereof must do so in accordance with national legislation. This is the responsibility of the aircraft owner and any person who is to perform any maintenance on the aircraft.</p>			

**WARNING**

**HAVE THE CORRECT TYPE (FOR FUEL FIRES) FIRE EXTINGUISHER AT HAND.**

**CLEAN UP SPILLED FUEL IMMEDIATELY AS IT CREATES A SAFETY HAZARD.**

**IT MAY BE EXPEDIENT TO DISCONNECT THE BATTERY GROUND TERMINAL WHILE WORKING ON ELECTRICAL EQUIPMENT.**

A finger strainer (1) forms part of each fuel tank pick-up (2), located just inboard (in the tank) from the wing root end rib (3), immediately below the fuel level sender mounting plate (4).

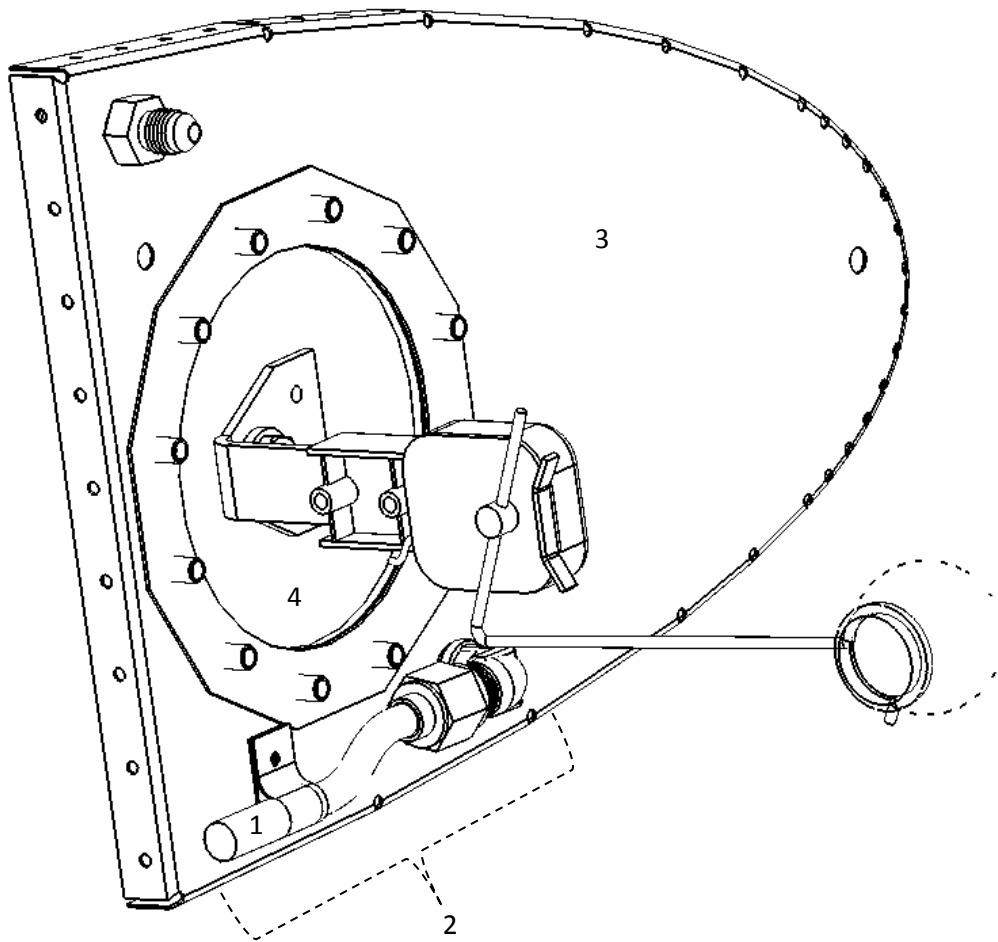

#### PROCEDURE (INSPECTION AND CLEANING)

1. Remove the fuel level sender assembly / assembly mounting plate (refer to paragraph 6.12).
2. Use a small angled mirror tool and small pencil flashlight / light source to inspect the finger strainer on the fuel pick-up. Under no circumstances use a match flame or cigarette lighter flame or an open bulb to provide light !!!!!!
3. Any observed clogging can be washed away and / or blown clear (with low pressure air). Blow towards end rib to prevent material being deeper into tank. Remove the cleared material from the tank cavity.
4. Ensure that no tools or foreign material remains behind in the tank cavity and refit the fuel level sender assembly (refer to paragraph 6.12) when finished.



## 7. AVIONICS AND INSTRUMENTS

The diagram below represents an instrument panel containing the required minimum instrumentation, together with typical back-up and additional instrumentation supplied with the aircraft. The instrument panel in any particular aircraft may differ from that illustrated in the diagram.



Figure 66: Standard instrument panel.

Refer to the key for Figure 66 on the next page.

The instrument panel contains the bulk of the electrical, flight and engine instruments (refer to Figure 66). They are described as follows:

1	Master switch and starter	13	Cabin heat activator
2	Ignition / "Magneto" switches	14	Cubby hole
3	Charge warning light (912 ULS)	15	12 V Power port / socket
4	MGL EFIS	16	Air vent
5	EFIS accessory warning light	17	Circuit breakers
6	Analogue airspeed indicator	18	Blank off / Ballistic recovery parachute activator handle (if fitted)
7	Analogue magnetic compass	19	Fuel selector valve
8	Analogue altimeter	20	Flap selector
9	MGL V6 COM transceiver	21	Electrical equipment switches
10	Blank off(s)	22	USB charge port
11	Analogue slip indicator		
12	Choke (912 ULS)		

NOTE: Rotax 912 iS equipped aircraft will have, in addition to the above, two switches for the electric fuel pumps in the fuel pump assembly

## 7.1 GENERAL MAINTENANCE AND SERVICE OF INSTRUMENTS

Refer to the applicable instrument manufacturer's documentation for information regarding maintenance, service, wiring diagrams and programming / set-up instructions (as applicable).

**7.2 REMOVAL / INSTALLATION OF INSTRUMENT PANEL AND INSTRUMENTS**

TOOLS / EQUIPMENT REQUIRED			
ITEM		QUANTITY	NOTES
1	2.5 mm Allen key / hex drive.	1	
2	As required for each instrument.	As required.	
The above list is not necessarily a complete list of all required tools and equipment needed. A calibrated torque wrench (with adequate range) and the correct size (as implied by the above tool list) accessories (sockets etc.) are implied for torquing bolts / nuts, if applicable. Refer to paragraph 1.5 for torque values.			
CONSUMABLE MATERIAL REQUIRED			
ITEM		QUANTITY	NOTES
1	Loctite 222.	As needed.	Instrument panel retaining screws.
The above list is not necessarily a complete list of all material needed. Refer to the Sling 2 construction manual.			
AUTHORISED PERSONNEL			
Any person performing maintenance of any kind on the aircraft or any component thereof must do so in accordance with national legislation. This is the responsibility of the aircraft owner and any person who is to perform any maintenance on the aircraft.			

**WARNING**  
**ENSURE MASTER SWITCH IS OFF.**  
**IT MAY BE EXPEDIENT TO DISCONNECT THE BATTERY GROUND TERMINAL WHILE WORKING ON ELECTRICAL EQUIPMENT.**

## **PROCEDURE (REMOVAL)**

### **PANEL:**

The instrument panel may be removed by removing the button head screws on the outside edge of the panel. Tilt the panel forward (into the cabin) to reveal the connections to the instruments and panel mounted equipment.

### **INSTRUMENTS:**

1. Before removing any electrical instrument, ensure that the master switch is OFF.
2. Before removing an individual instrument, carefully disconnect wires, hoses and / or other cables, as the case may be.
3. Remove the instrument.

## **PROCEDURE (INSTALLATION)**

### **PANEL:**

Reverse the procedure for installation. Apply thread locking sealant to the instrument panel mounting screws before fitment.

### **INSTRUMENTS:**

1. Before installing any electrical instrument, ensure that the master switch is OFF.
2. When installing instruments, follow the recommendations below:
  - Do not over-tighten bolts / screws as instrument casings may break or crack.
  - Ensure hoses are free of any foreign matter and that no tight radius turns are present, as this may choke the hose or cause malfunction.
  - Ensure proper connection and tightening of all instrument electrical connectors.
  - Ensure proper connection of pneumatic tubes.
3. Perform a pitot system leak test if any instrument connecting to the pitot system was removed / installed. Refer to paragraph 7.3.1.
4. Perform a static system leak test if any instrument connecting to the static system was removed / installed. Refer to paragraph 7.3.2.
5. Verify the operation of any electrical instrument which were replaced / installed.

### 7.3 PITOT AND STATIC SYSTEMS

Refer to Figure 67. The system consists of a pitot tube mounted below the left wing and a static port behind the instrument panel. The pitot tube includes a second port set on an angled bevel below the main port for the purpose of determining aircraft angle of attack (displayed on the EFIS). Flexible plumbing connects the pitot tube and static ports to the pressure instruments (being an analogue airspeed indicator, altimeter, vertical speed indicator and the EFIS).

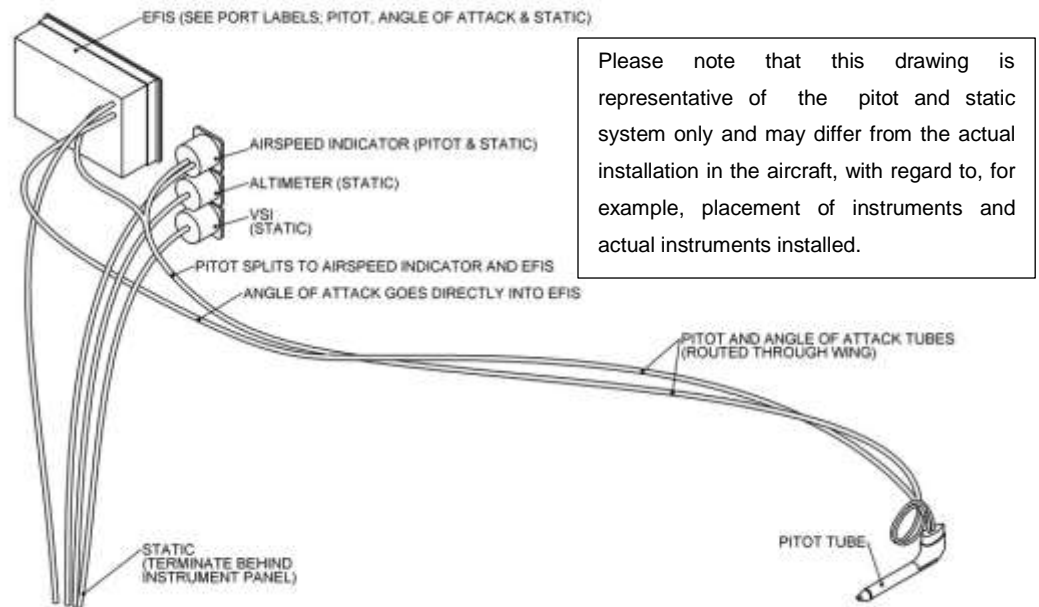

Figure 67: Representative pitot and static system.

### 7.3.1 PITOT SYSTEM LEAK TEST

For safety reasons and to ensure correct airspeed readings, it is important to test the system for leaks.

TOOLS / EQUIPMENT REQUIRED			
ITEM	QUANTITY	NOTES	
1	Rubber hose with inside diameter equal to pitot outside diameter, at least 30 cm length.	1	
The above list is not necessarily a complete list of all required tools and equipment needed. A calibrated torque wrench (with adequate range) and the correct size (as implied by the above tool list) accessories (sockets etc.) are implied for torquing bolts / nuts, if applicable. Refer to paragraph 1.5 for torque values.			
AUTHORISED PERSONNEL			
Any person performing maintenance of any kind on the aircraft or any component thereof must do so in accordance with national legislation. This is the responsibility of the aircraft owner and any person who is to perform any maintenance on the aircraft.			

### PROCEDURE

1. Ensure that all instruments (that utilise the pitot system) are connected.
2. Connect a piece of rubber hose approximately 30 centimetres long to the pitot tube, Ensure that there is no leakage at the pitot tube to hose interface.
3. Close off the opposite end of the hose and slowly roll it up until the airspeed indicator shows cruise speed. Stop rolling up the tube at the cruise speed indication.
4. Observe the airspeed indication for an adequate period.
5. A constant reading is an indication of no leak in the pitot lines.
6. Unroll the tube slowly until fully extended. Remove the tube from the pitot.
7. Fit pitot cover, if required.

### CAUTION

**AVOID BLOWING AIR THROUGH THE PITOT TOWARDS CONNECTED INSTRUMENTS, AS THIS MAY CAUSES IMMEDIATE DAMAGE. DO NOT APPLY SUCTION TO CONNECTED PITOT LINES / INSTRUMENTS.**

### 7.3.2 STATIC SYSTEM LEAK TEST

TOOLS / EQUIPMENT REQUIRED			
	ITEM	QUANTITY	NOTES
1	Vacuum pump.	1	
2	Piping to connect vacuum pump to static system T-piece.	As needed.	
<p>The above list is not necessarily a complete list of all required tools and equipment needed. A calibrated torque wrench (with adequate range) and the correct size (as implied by the above tool list) accessories (sockets etc.) are implied for torquing bolts / nuts, if applicable. Refer to paragraph 1.5 for torque values.</p>			
AUTHORISED PERSONNEL			
<p>Any person performing maintenance of any kind on the aircraft or any component thereof must do so in accordance with national legislation. This is the responsibility of the aircraft owner and any person who is to perform any maintenance on the aircraft.</p>			

#### PROCEDURE

1. Ensure that all instruments (that utilise the static system / port) are connected.
2. One of the T-pieces connected into the static system piping (behind the instrument panel) has a free end, which acts as a static port. Connect the vacuum pump to this free end.
3. Set the altimeter / EFIS to indicate 0 ft (i.e. set QFE on the subscale) or to indicate elevation above sea level (i.e. set QNH on subscale).
4. Apply a vacuum equivalent to 308.4 m (1000 ft) (differential pressure of approximately 36.2302 mb (1.07" Hg) with ambient) and hold.
5. Monitor the indication on the altimeter or EFIS. Any leak should not exceed 30.48 m (100 ft) per minute (decrease in differential pressure of approximately 0.3555 mb (0.0105" Hg) per minute).

### 7.3.3 PITOT AND / OR STATIC SYSTEM CLEANING AND SERVICING

AUTHORISED PERSONNEL
Any person performing maintenance of any kind on the aircraft or any component thereof must do so in accordance with national legislation. This is the responsibility of the aircraft owner and any person who is to perform any maintenance on the aircraft.

#### PROCEDURE

1. Open the instrument panel (refer to paragraph 7.2).
2. Disconnect the pneumatic tubes / lines from the applicable instrument(s).
3. Blow (low pressure) air into the tubes / lines, in the direction of the port (and never towards the instrument) to clear any possible obstructions.
4. Reconnect the pneumatic line(s) to the instrument(s).
5. Close the instrument panel (refer to paragraph 7.2).
6. Perform (if applicable) a pitot system leak test before flight. Refer to paragraph 7.3.1.
7. Perform (if applicable) a static system leak test before flight. Refer to paragraph 7.3.2.

CAUTION
<b>AVOID BLOWING AIR THROUGH THE PITOT OR STATIC PORTS TOWARDS CONNECTED INSTRUMENTS, AS THIS MAY CAUSES IMMEDIATE DAMAGE. DO NOT APPLY SUCTION TO PITOT LINES / INSTRUMENTS.</b>



## 7.4 AHRS AND COMPASS

The aircraft is equipped with AHRS and compass sensors which provide attitude and heading information to the EFIS. The sensors are each mounted on a plate which is in turn attached to the cabin floor with adhesive foam blocks.

### 7.4.1 AHRS AND / OR COMPASS SENSOR REMOVAL / INSTALLATION

TOOLS / EQUIPMENT REQUIRED			
	ITEM	QUANTITY	NOTES
1	Flat screwdriver.	1	
2	Flat screwdriver (small).	1	
The above list is not necessarily a complete list of all required tools and equipment needed. A calibrated torque wrench (with adequate range) and the correct size (as implied by the above tool list) accessories (sockets etc.) are implied for torquing bolts / nuts, if applicable. Refer to paragraph 1.5 for torque values.			
CONSUMABLE MATERIAL REQUIRED			
	ITEM	QUANTITY	NOTES
1	Adhesive lined foam.	As needed.	If adhesive foam was removed with removal of sensor(s).
The above list is not necessarily a complete list of all material needed. Refer to the Sling 2 construction manual.			
AUTHORISED PERSONNEL			
Any person performing maintenance of any kind on the aircraft or any component thereof must do so in accordance with national legislation. This is the responsibility of the aircraft owner and any person who is to perform any maintenance on the aircraft.			

#### WARNING

**ENSURE MASTER AND ALL AVIONIC / INSTRUMENT SWITCHES ARE OFF.  
IT MAY BE EXPEDIENT TO DISCONNECT THE BATTERY GROUND TERMINAL WHILE WORKING ON  
ELECTRICAL EQUIPMENT.**

#### CAUTION

**BE PREPARED WITH A HELPER OR SUPPORT STAND TO HANDLE THE WEIGHT  
AND / OR AWKWARDNESS OF THE OBJECT (SEAT) TO BE REMOVED / INSTALLED.**

## PROCEDURE (REMOVAL)

Retain any bolts, nuts (except lock-nuts) spacers, screws and washers (with the exception of lock-washers) for reassembly.

1. Remove the port seat (refer to paragraph 4.3.2.1).
2. Undo the screws retaining the connector (1) to the sensor (2) and disconnect the connector.

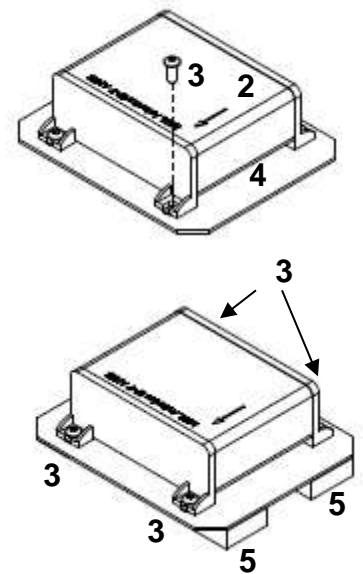

3. Undo the four screws (3) retaining the sensor to the plate (4) and remove the unit.
4. Alternatively, mark the location of the sensor / foam mounting block(s) footprint (for later replacement in the same location) and tear the unit (attached to plate) from the foam (5). Clean foam / adhesive residue from the cabin floor.

## PROCEDURE (INSTALLATION)

1. Reverse the above procedure (removal), paying close attention to the following:
  - Inspect the mounting screws for damage before fitting. Replace if necessary.
2. Inspect for alignment, security of attachment and proper connector attachment before replacing the seat.

## 7.5 HEADPHONE SOCKETS

The aircraft is equipped with standard aviation specification headphone sockets, located in / on brackets on the cabin rear bulkhead, in the centre between the seats.

### 7.5.1 HEADPHONE SOCKET REMOVAL / INSTALLATION

TOOLS / EQUIPMENT REQUIRED			
ITEM		QUANTITY	NOTES
1	2 mm Allen key.	1	
2	½ inch Spanner.	1	
3	Solder iron.	1	Installation.
4	Heat gun.	1	Installation.
The above list is not necessarily a complete list of all required tools and equipment needed. A calibrated torque wrench (with adequate range) and the correct size (as implied by the above tool list) accessories (sockets etc.) are implied for torquing bolts / nuts, if applicable. Refer to paragraph 1.5 for torque values.			
CONSUMABLE MATERIAL REQUIRED			
ITEM		QUANTITY	NOTES
1	Loctite 222.	As needed.	Bracket mounting screws.
2	Heat shrink.	As needed.	Installation.
3	Solder.	As needed.	Installation.
The above list is not necessarily a complete list of all material needed. Refer to the Sling 2 construction manual.			
AUTHORISED PERSONNEL			
Any person performing maintenance of any kind on the aircraft or any component thereof must do so in accordance with national legislation. This is the responsibility of the aircraft owner and any person who is to perform any maintenance on the aircraft.			

## PROCEDURE (REMOVAL)

1. Remove the screws (1) retaining the socket bracket (2) to the fuselage.

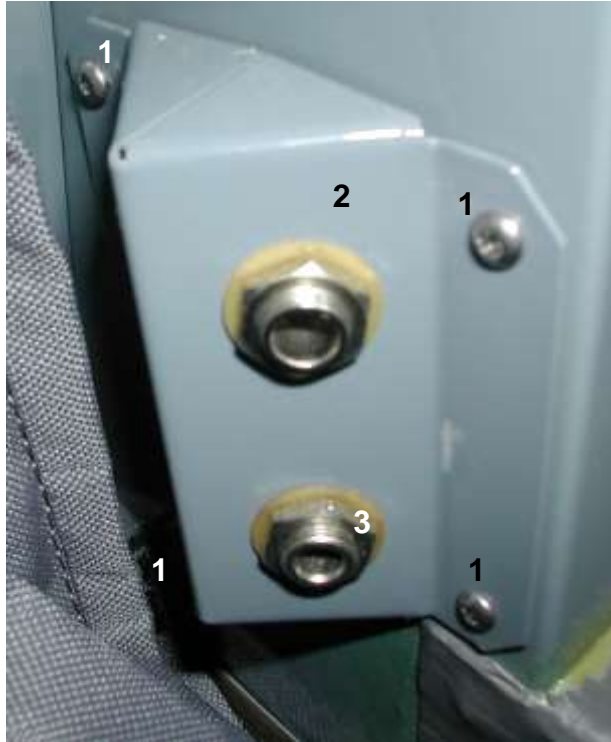

2. Undo the nut (3) retaining the socket to the mounting plate and pull the socket from the plate.
3. Remove the heat shrink on the wire connections and desolder the wire connections.

## PROCEDURE (INSTALLATION)

Refer to paragraph 13.14 for the wiring connections / information for each socket / headphone position.

1. Reverse the above procedure (removal) for installation, paying close attention to the following:
  - Observe the correct washer / insulator placement (refer to Figure 68).
  - Shrink the heat shrink with a suitable heat source (e.g. a heat gun). Do not burn / melt the heat shrink.

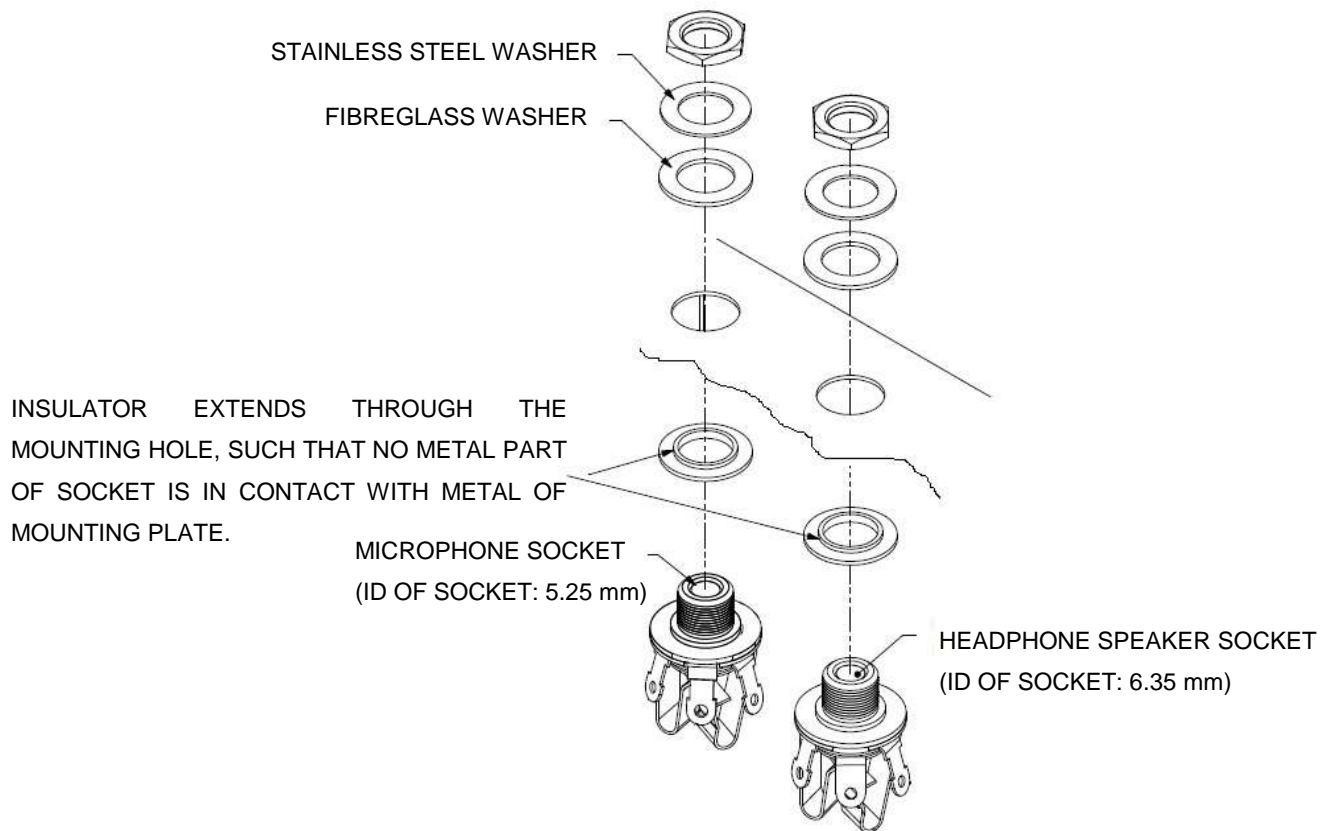

Figure 68: Headphone socket installation.

**7.6 ANTENNAE**

**7.6.1 VHF COMMUNICATION ANTENNA**

The VHF antenna is attached to the rear dorsal fuselage.

**7.6.1.1 VHF ANTENNA REMOVAL / INSTALLATION**

TOOLS / EQUIPMENT REQUIRED			
ITEM		QUANTITY	NOTES
1	2.5 mm Allen key.	1	
The above list is not necessarily a complete list of all required tools and equipment needed. A calibrated torque wrench (with adequate range) and the correct size (as implied by the above tool list) accessories (sockets etc.) are implied for torquing bolts / nuts, if applicable. Refer to paragraph 1.5 for torque values.			
CONSUMABLE MATERIAL REQUIRED			
ITEM		QUANTITY	NOTES
1	Loctite 222.	As needed.	Antenna mounting screws.
2	Clear silicone.	As needed.	
The above list is not necessarily a complete list of all material needed. Refer to the Sling 2 construction manual.			
AUTHORISED PERSONNEL			
Any person performing maintenance of any kind on the aircraft or any component thereof must do so in accordance with national legislation. This is the responsibility of the aircraft owner and any person who is to perform any maintenance on the aircraft.			

**WARNING**

**ENSURE MASTER AND ALL AVIONIC / INSTRUMENT SWITCHES ARE OFF.**

**IT MAY BE EXPEDIENT TO DISCONNECT THE BATTERY GROUND TERMINAL WHILE WORKING ON ELECTRICAL EQUIPMENT.**

## PROCEDURE (REMOVAL)

Retain any bolts, nuts (except lock-nuts) spacers, screws and washers (with the exception of lock-washers) for reassembly.

1. Unscrew the four bolts retaining the antenna to the fuselage.
2. Separate the antenna from the fuselage so that the BNC connector is exposed.
3. Undo the BNC connector and separate the cable and antenna.

## PROCEDURE (INSTALLATION)

1. Reverse the above procedure (removal), paying close attention to the following:
  - Inspect the mounting screws for damage before fitting. Replace if necessary.
  - Ensure that the base of the antenna makes proper contact with the fuselage. Clean the area if necessary.
  - Inspect the rubber seal for damage before fitment. Replace if necessary.
  - Apply thread locking sealant to the antenna mounting screws before fitting.
2. Apply clear silicone (refer to Figure 69) around the interface between the fuselage and antenna base. Allow to dry.

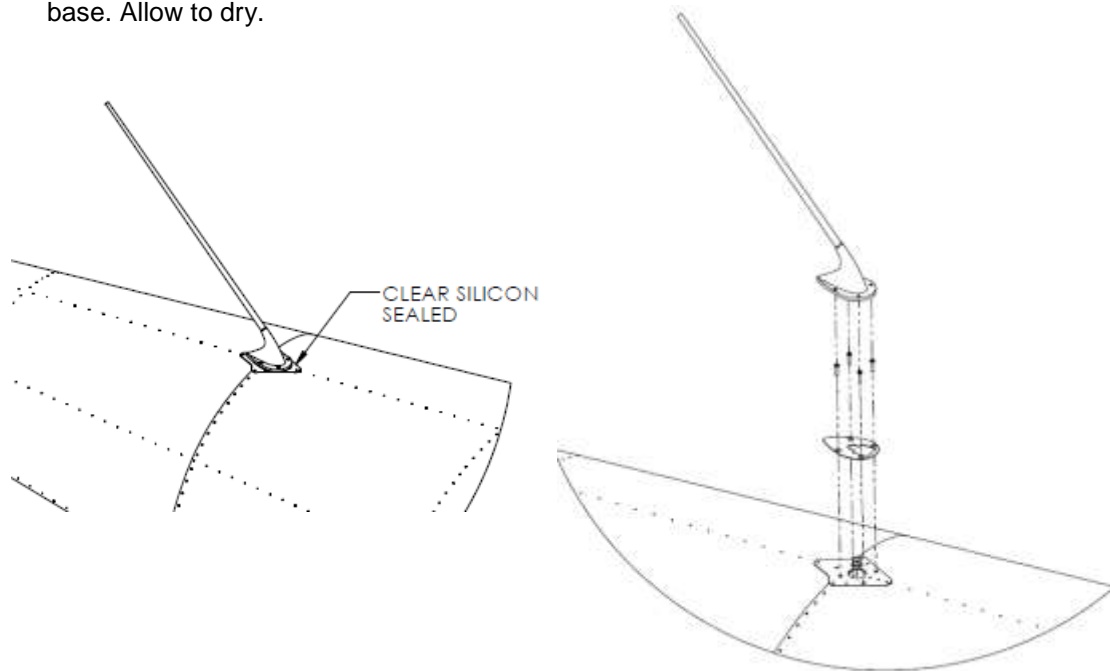

Figure 69: VHF antenna installation.

3. Apply power to the radio and perform a communication test.

## 7.6.2 GPS ANTENNA

The GPS antenna is mounted in the engine compartment on a bracket attached to the firewall. Refer to paragraph 4.

### 7.6.2.1 GPS ANTENNA REMOVAL / INSTALLATION

TOOLS / EQUIPMENT REQUIRED		
ITEM	QUANTITY	NOTES
1	Side cutter.	1
The above list is not necessarily a complete list of all required tools and equipment needed. A calibrated torque wrench (with adequate range) and the correct size (as implied by the above tool list) accessories (sockets etc.) are implied for torquing bolts / nuts, if applicable. Refer to paragraph 1.5 for torque values.		
CONSUMABLE MATERIAL REQUIRED		
ITEM	QUANTITY	NOTES
1	Tie wraps.	As needed.
Installation.		
The above list is not necessarily a complete list of all material needed. Refer to the Sling 2 construction manual.		
AUTHORISED PERSONNEL		
Any person performing maintenance of any kind on the aircraft or any component thereof must do so in accordance with national legislation. This is the responsibility of the aircraft owner and any person who is to perform any maintenance on the aircraft.		

#### **WARNING**

**ENSURE MASTER AND ALL AVIONIC / INSTRUMENT SWITCHES ARE OFF.  
IT MAY BE EXPEDIENT TO DISCONNECT THE BATTERY GROUND TERMINAL WHILE WORKING ON  
ELECTRICAL EQUIPMENT.**



### PROCEDURE (REMOVAL)

1. Unplug the antenna cable from the iBOX interface (below the instrument panel).
2. Cut the tie wraps (1) retaining the antenna (2) to the bracket (3). Cut any tie wraps securing the cable (e.g. to other cables) and pull the cable through the rubber grommet (4) in the mounting bracket.



### PROCEDURE (INSTALLATION)

1. Reverse the above procedure (removal) for installation.
2. Inspect for security of attachment.
3. Apply power and verify GPS operation on the EFIS.

## **8. UTILITY SYSTEMS**

### **8.1 CABIN HEATING AND COOLING**

The heating system exhaust vent is located near the rudder pedals on the passenger side of the cabin. Two fresh air vents are found on the left and right sides of the instrument panel, each with a shut-off valve that can be directed through 180 degrees. The heating system is comprised of a heat exchanger on the exhaust muffler, a hot air shut-off valve connected to a control (ON/OFF) knob situated in the central instrument panel, and the above-mentioned exhaust outlet.

#### **8.1.1 HEAT EXCHANGER ASSEMBLY REMOVAL AND INSTALLATION**

Refer to paragraph 5.2.10.

## 9. BRAKE SYSTEM

Refer to Figure 70. The brake system consists of a brake fluid reservoir, a master cylinder and two disc brakes assemblies. An intercept valve activates the parking brake. Braking action is through a lever located on the cabin tunnel between seats. The hydraulic circuit intercept valve is also located between seats and, when closed with lever pulled, keeps circuit under pressure and aircraft's parking brake on

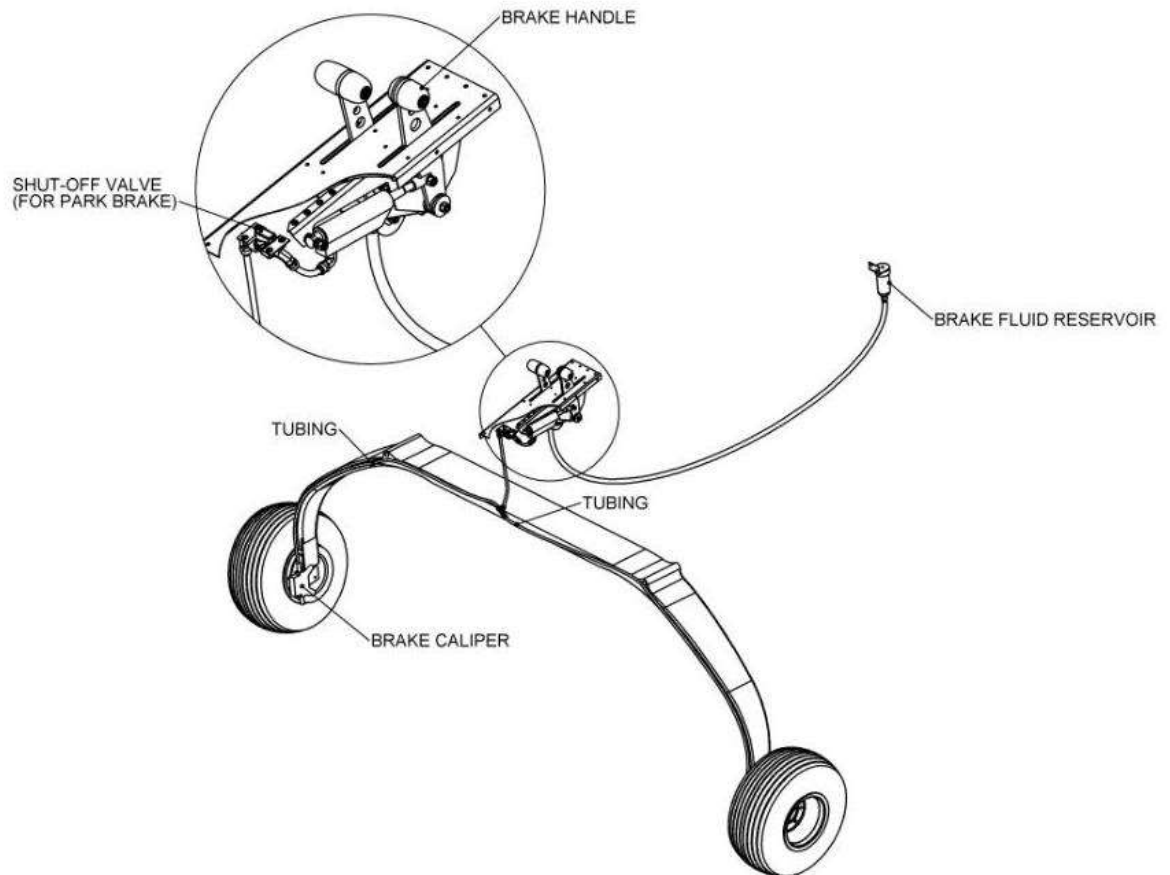

Figure 70: Brake system.

**9.1 BRAKE FLUID DRAINING, REPLACEMENT AND BRAKE SYSTEM BLEEDING**

TOOLS / EQUIPMENT REQUIRED			
ITEM	QUANTITY	NOTES	
1	¼ inch Spanner.	1	
2	Manual pump to pump brake fluid.	1	Pump method of replacement only.
3	Container for drained fluid.	As needed.	
<p>The above list is not necessarily a complete list of all required tools and equipment needed. A calibrated torque wrench (with adequate range) and the correct size (as implied by the above tool list) accessories (sockets etc.) are implied for torquing bolts / nuts, if applicable. Refer to paragraph 1.5 for torque values.</p>			
CONSUMABLE MATERIAL REQUIRED			
ITEM	QUANTITY	NOTES	
1	Brake fluid.	As needed.	Refer to paragraph 1.4.
<p>The above list is not necessarily a complete list of all material needed. Refer to the Sling 2 construction manual.</p>			
AUTHORISED PERSONNEL			
<p>Any person performing maintenance of any kind on the aircraft or any component thereof must do so in accordance with national legislation. This is the responsibility of the aircraft owner and any person who is to perform any maintenance on the aircraft.</p>			

**WARNING**

**SPILLED BRAKE FLUID CREATES A SAFETY HAZARD. CLEAN UP SPILLED BRAKE FLUID BEFORE CONTINUING WITH WORK.**

### PROCEDURE (DRAIN)

1. Open the park brake shut-off valve.
2. Remove the plastic cap (1) and loosen and remove the brake calliper nipple (2). Let the brake fluid drain out in a container.



### PROCEDURE (FILL)

#### METHOD 1 (PUMP)

1. Remove the brake fluid reservoir cap.
2. Ensure park brake shut-off valve is open.
3. Loosen the nipple (2) on the brake calliper enough to allow the passage of fluid. Attach a pipe over the nipple and to a manually operated pump feeding from a reservoir filled with the correct brake fluid.
4. Use the pump to pump brake fluid until it reaches the bottom of the brake fluid reservoir. Tighten the nipple and remove the pipe.
5. Top up the brake fluid reservoir and replace the cap.
6. Apply the brakes and verify for correct operation and the absence of sponginess.

#### METHOD 2 (GRAVITY)

3. Ensure park brake shut-off valve is open.
4. Loosen the brake calliper nipple (2) slightly to allow the passage of air and the seepage of brake fluid.
5. Remove the brake fluid reservoir cap.
6. Add brake fluid to the reservoir and let it run down the fluid lines to the main wheel brake assemblies, until the fluid exits without air bubbles.

7. Apply the brakes and verify for correct operation and the absence of sponginess.

### **PROCEDURE (BLEED)**

Both main wheels are bled independently.

1. Pull the brake lever to pressurise the system.
2. Loosen the brake calliper nipple to allow the fluid to spurt out.
3. Tighten the nipple and release the brake lever.
4. Repeat steps 1 to 3 until the fluid comes out smoothly with the absence of air bubbles (no longer spurts).
5. Top up the brake fluid reservoir.

## **9.2 BRAKE MECHANISM REMOVAL / INSTALLATION**

Refer to paragraph 4.4.1.3.

### 9.3 BRAKE DISC REPLACEMENT

TOOLS / EQUIPMENT REQUIRED		
ITEM	QUANTITY	NOTES
1	4 mm Allen key / hex drive.	1
The above list is not necessarily a complete list of all required tools and equipment needed. A calibrated torque wrench (with adequate range) and the correct size (as implied by the above tool list) accessories (sockets etc.) are implied for torquing bolts / nuts, if applicable. Refer to paragraph 1.5 for torque values.		
AUTHORISED PERSONNEL		
Any person performing maintenance of any kind on the aircraft or any component thereof must do so in accordance with national legislation. This is the responsibility of the aircraft owner and any person who is to perform any maintenance on the aircraft.		

#### PROCEDURE (REMOVAL)

Retain any bolts, nuts (except lock-nuts) spacers, screws and washers (with the exception of lock-washers) for reassembly.

1. Remove the main wheel (refer to paragraph 4.4.1.2).
2. Unfasten the button head screws retaining the brake disc to the wheel assembly and remove the brake disc.

#### PROCEDURE (INSTALLATION)

1. Reverse the above procedure (removal) for installation, paying close attention to the following:
  - Inspect all bolts and / or screws for damage. Replace if necessary.
  - Inspect the brake disc for damage and / or cracks before fitment.
2. Before flight, verify correct operation of the brake mechanism and function.

**9.4 BRAKE LINING REPLACEMENT**

TOOLS / EQUIPMENT REQUIRED			
	ITEM	QUANTITY	NOTES
1	4 mm Drill bit and drive (electric or hand drill).	1 Set.	
2	7/16 Spanner	2	Axle / spat mounting plate retaining nut and bolts.
3	Hammer, punch and anvil / bucking bar (suitable for rivets supplied with the brake linings).	1 Set.	
<p>The above list is not necessarily a complete list of all required tools and equipment needed. A calibrated torque wrench (with adequate range) and the correct size (as implied by the above tool list) accessories (sockets etc.) are implied for torquing bolts / nuts, if applicable. Refer to paragraph 1.5 for torque values.</p>			
AUTHORISED PERSONNEL			
<p>Any person performing maintenance of any kind on the aircraft or any component thereof must do so in accordance with national legislation. This is the responsibility of the aircraft owner and any person who is to perform any maintenance on the aircraft.</p>			



## PROCEDURE (REMOVAL)

1. Remove the main wheel (refer to paragraph 4.4.1.2) and obtain the first brake lining mounting plate / calliper (1).
2. The spat mounting plate (2) prevents the rear calliper (3) from sliding out of plate (4) attached to the strut by the axle mounting bolts (5). Undo the four axle bolts and nuts (5) to release the spat mounting plate (2), Remove the spat mounting plate (2), Remove the spat mounting plate.

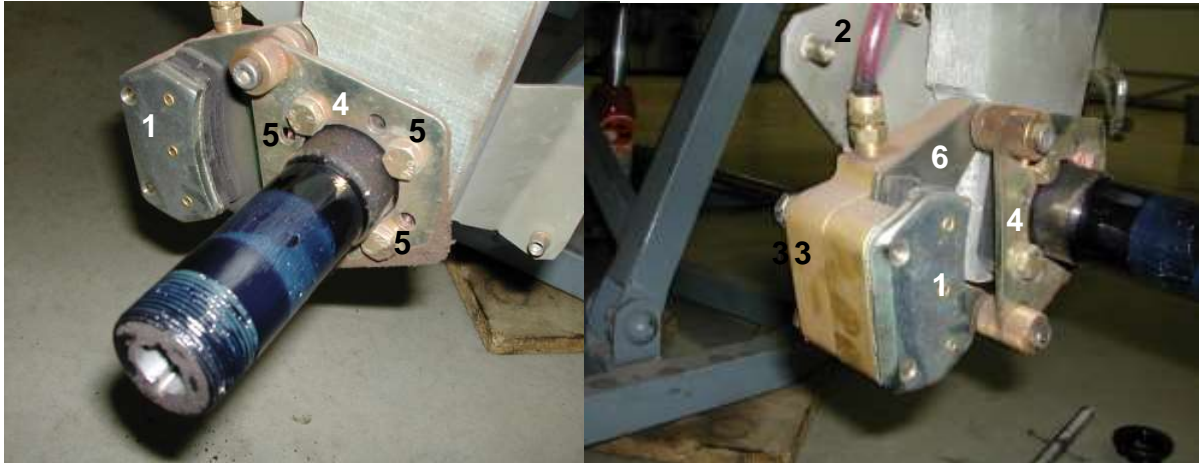

3. To obtain the second brake lining mounting plate (6), slide the calliper (3) out of plate (4), then slide the brake lining mounting plate (6) off the calliper. Note that in the photos below the calliper (3) is shown disconnected from the brake fluid supply line. This is not required.

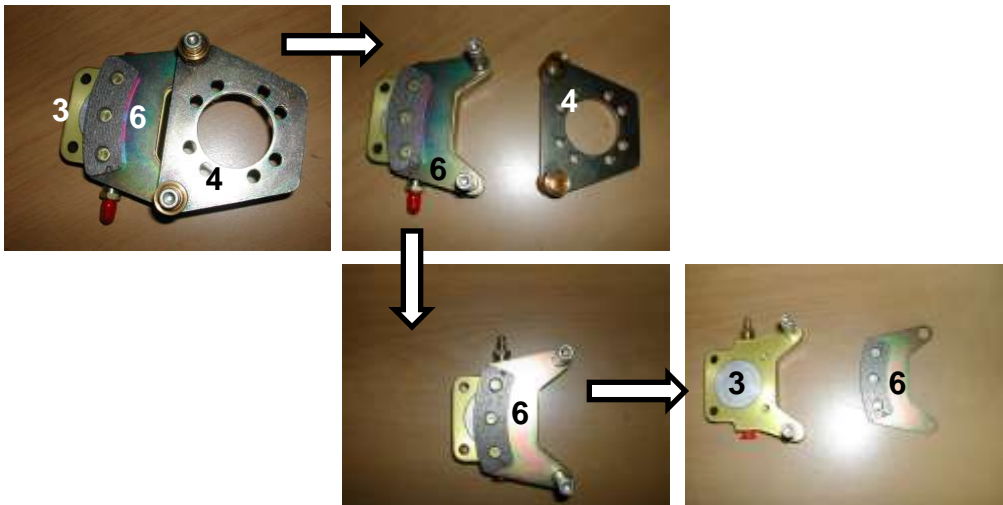

## PROCEDURE (REPLACEMENT)

1. Drill out the rivets (1) to remove the linings from the mounting plates (2).
2. Set the new linings in place, insert the brass rivets (supplied with the linings) and set the rivets.



## PROCEDURE (INSTALLATION)

1. Reverse the above procedure (removal) to install, paying close attention to the following:
  - Inspect the new brake linings for damage before use. Inspect for damage and the formation of cracks which may have resulted from the riveting process.
  - Note that the caliper is fitted into plate (1) such that the grooved sides of the brass fixtures (2) in plate (1) faces away from the brake caliper (3), i.e. plate (1) must be fitted correctly (orientation) around the axle.



This plate mounted around axle, with the grooved sides in the brass fixtures facing the wheel.

2. Inspect for security of attachment.
3. Before flight, verify correct operation of the brake mechanism and function.

## 10. ELECTRICAL SYSTEM

### GENERAL

This aircraft electrical system consists of a 12 V DC circuit. An 17 Ah lead acid battery provides the energy to drive the starter and acts as an emergency standby supply of electrical power in case of an alternator malfunction.

The EFIS and iBox are provided with a 5 Ah back-up battery which charges via the back-up battery charging circuit (refer to Figure 91).

The RDAC unit, compass (not shown) and AHRS unit (not shown) are powered from the iBox unit. Refer to the MGL Avionics iBOX installation manual.

### 914 UL AND 912 ULS

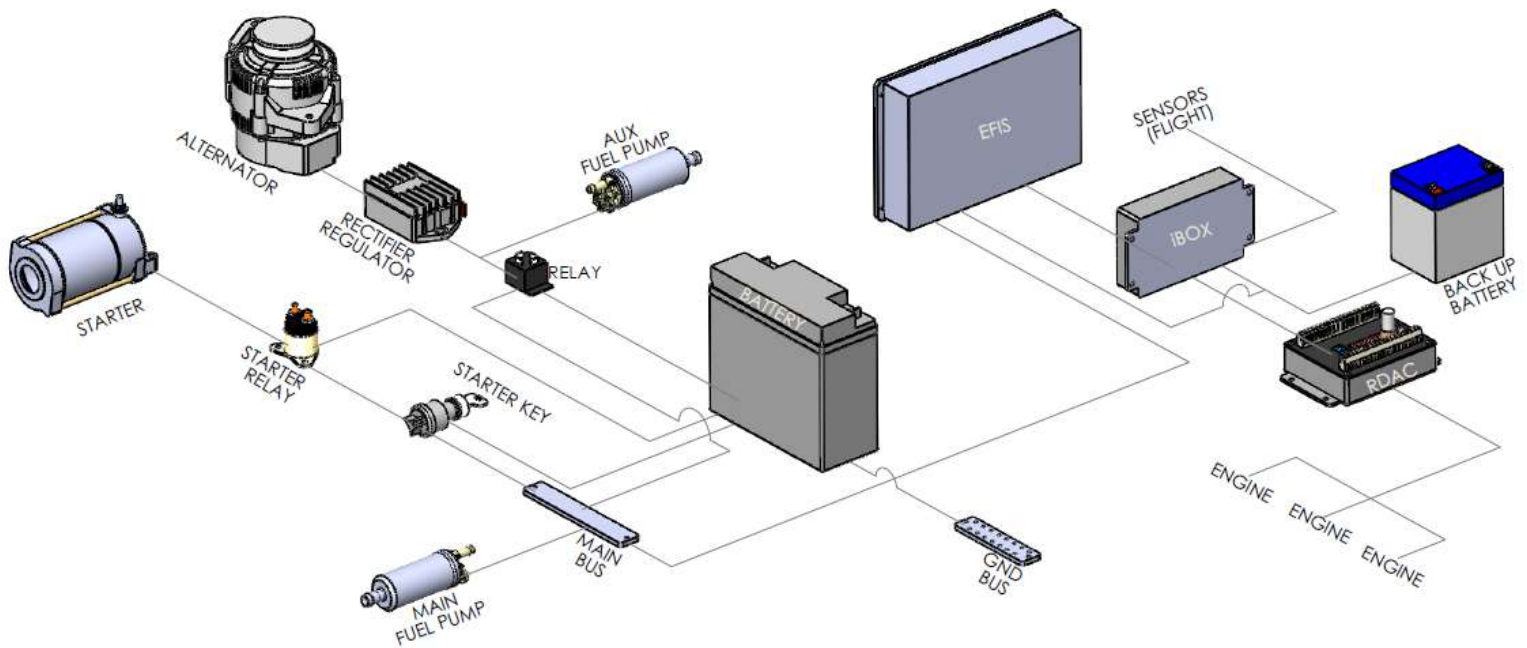

Figure 71: Electrical system – 914 UL equipped aircraft (overview).

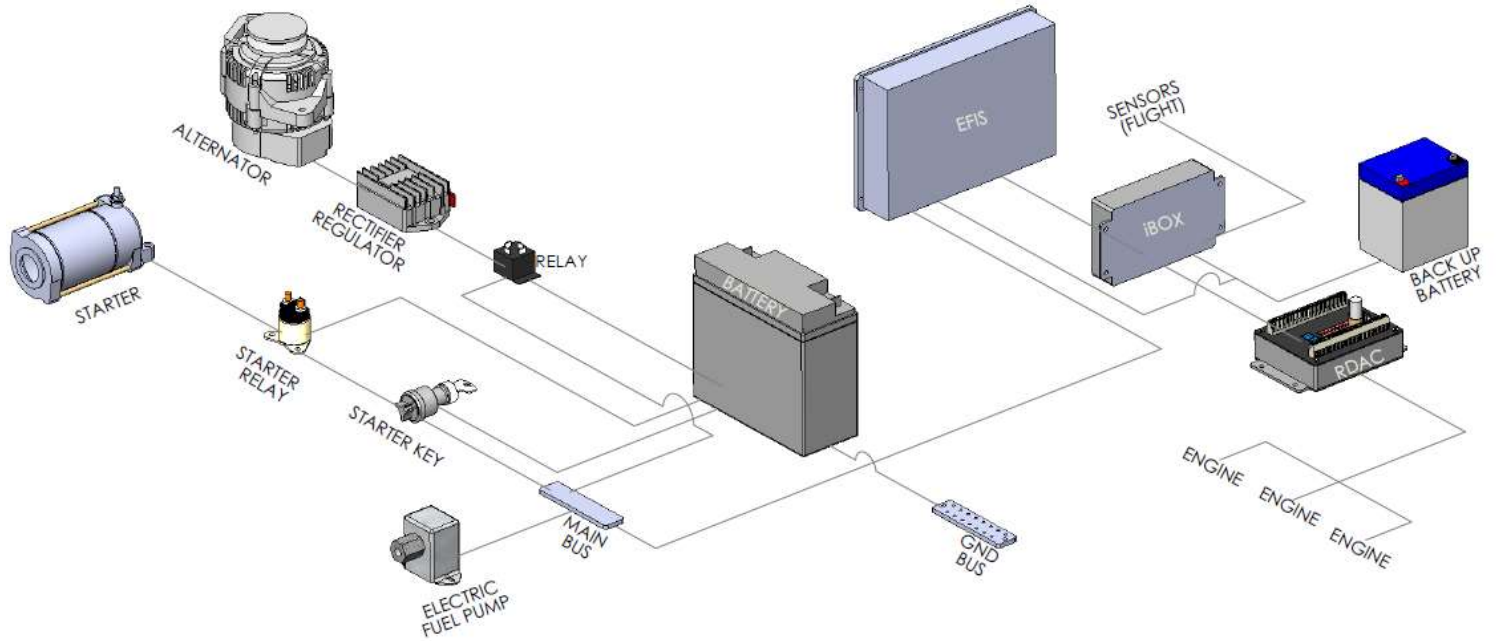

Figure 72: Electrical system – 912 ULS equipped aircraft (overview).

A single-phase alternator (integral to the engine) (912 ULS and 914 UL) connected to a regulator / rectifier (mounted in the cabin) supplies DC power to the main bus bar and to recharge the battery. The supply end of the rectifier is connected to the main bus and battery through a circuit breaker mounted on the instrument panel and a 12 V relay. A red warning light on the instrument panel will (indicating to the pilot) when the alternator is not operating. Electrical service users are connected between the main bus and the ground bus via switches and / or circuit breakers located on the instrument panel. Refer to paragraph 13 for electrical wiring diagrams.

912 iS

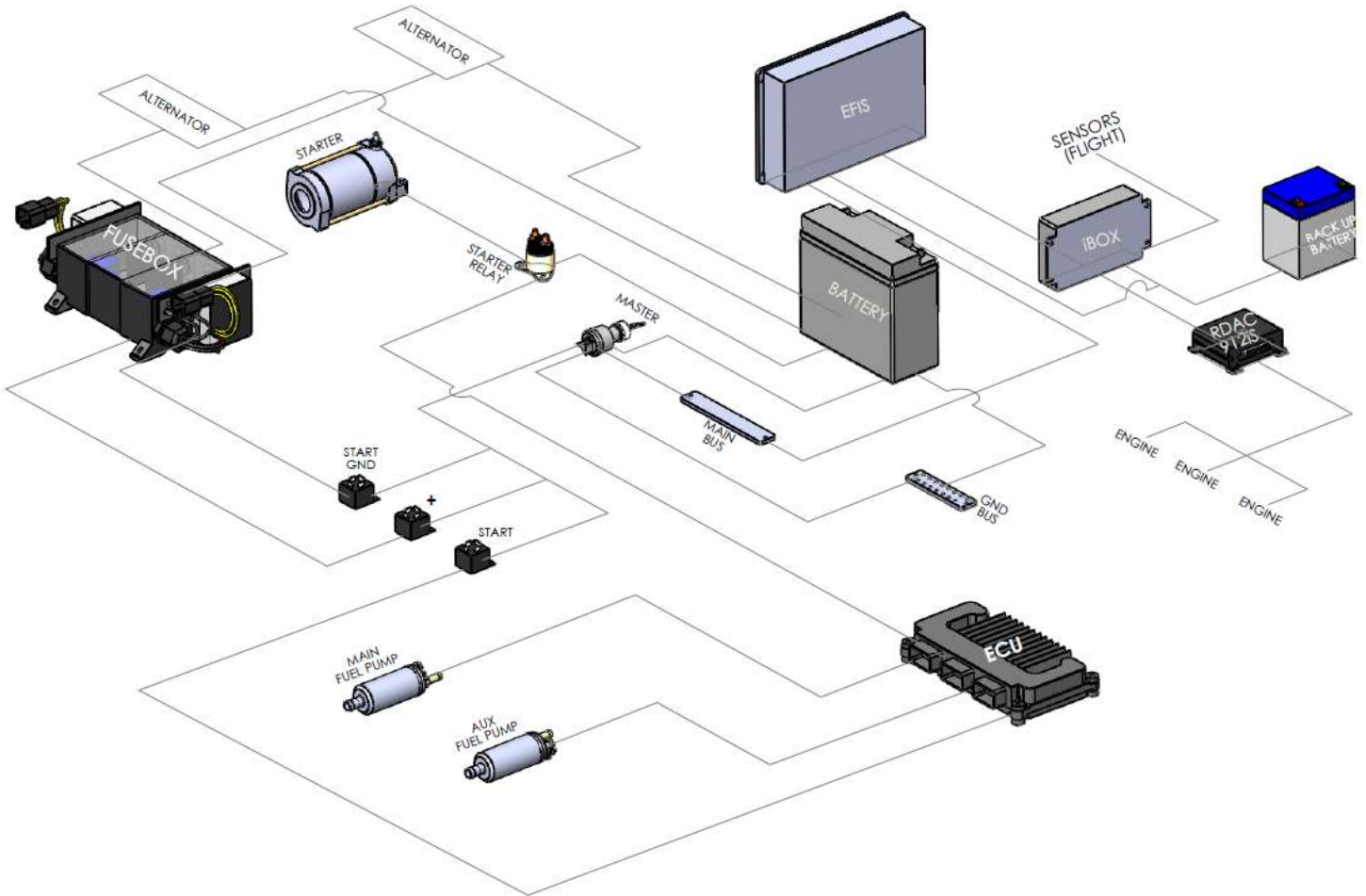

Figure 73: Electrical system – 912 iS equipped aircraft (overview).

The 912 iS engine is equipped with two three-phase alternators. One alternator (Alternator A) supplies power to the EMS / ECU. The other (Alternator B) is available to the aircraft systems and to charge the battery. Refer to the applicable engine manual(s) for more information. Electrical service users are connected between the main bus and the ground bus via switches and / or circuit breakers located on the instrument panel.

The EMS / ECU can be powered from the main battery (as a back-up power source).

Refer to paragraph 13 for electrical wiring diagrams.

## TYPICAL ELECTRICAL EQUIPMENT

The following table lists typical electrical equipment:

	Description		
1	Alternator	17	Oil pressure sensor and fuel flow sensor (912 ULS, 914 UL)
2	Alternator I(charge)I light	18	Oil temperature sensor
3	Battery	19	Propeller (Airmaster) and propeller controller (if fitted)
4	Circuit breakers	20	RDAC and iBox
5	Cylinder head temperature sensors and exhaust gas temperature sensors	21	Regulator / rectifier
6	Electrical and electronic instruments and radio	22	Starter
7	Elevator and Aileron autopilot servos, turbocharger waste gate servo (914 UL)	23	Strobe light
8	Flap actuator motor	24	Strobe light power supply
9	Flap controller	25	Strobe light switch
10	Ignition systems	26	Trim tab actuator motor
11	Landing and taxi light switches	27	Switches, trim tab switch
12	Landing and taxi lights	28	Electrical fuel pump(s)
13	Master / ignition / starter switch		
14	Master relay		
15	Navigation lights		
16	Navigation lights switch		

**10.1 BATTERY REMOVAL / INSTALLATION**

TOOLS / EQUIPMENT REQUIRED		
ITEM	QUANTITY	NOTES
1	8 mm Spanner.	2
<p>The above list is not necessarily a complete list of all required tools and equipment needed. A calibrated torque wrench (with adequate range) and the correct size (as implied by the above tool list) accessories (sockets etc.) are implied for torquing bolts / nuts, if applicable. Refer to paragraph 1.5 for torque values.</p>		
AUTHORISED PERSONNEL		
<p>Any person performing maintenance of any kind on the aircraft or any component thereof must do so in accordance with national legislation. This is the responsibility of the aircraft owner and any person who is to perform any maintenance on the aircraft.</p>		

**WARNING**  
**MASTER / IGNITION SWITCHES OFF.**

**WARNING**

**ALLOW THE ENGINE AND APPLICABLE COMPONENTS TO COOL COMPLETELY BEFORE PERFORMING ANY WORK OR INSPECTION IN THE ENGINE COMPARTMENT. HOT ENGINE COMPONENTS CAN CAUSE SERIOUS BURNS OR CAN IGNITE SPILLED FLUID / VAPOUR.**

## PROCEDURE (REMOVAL)



1. Engine stopped.
2. Master switch OFF.
3. Remove the top engine cowling (refer to paragraph 5.1.1).
4. First disconnect the ground (negative) cable (1, black) and then the positive cable (2, red) from the battery terminals (3).
5. Loosen the tie-in strap (4) and remove the battery (5) from the bracket (6).

## PROCEDURE (INSTALLATION)

1. Master switch OFF. All other switches OFF.
2. Thoroughly clean (and dry) the inside and outside of the battery bracket.
3. Insert the battery into the bracket. Ensure that the battery is inserted the right way round, with the negative (-) terminal towards the starboard wing and the positive terminal (+) towards the port wing.
4. First connect the positive cable (red) and then the negative cable (black) to the corresponding battery terminals.
5. Secure the battery with the tie in strap.
6. Inspect for correct connection and security of attachment.
7. Replace the top cowl (refer to paragraph 5.1.1).



**10.2 EFIS BACK-UP BATTERY REMOVAL / INSTALLATION**

TOOLS / EQUIPMENT REQUIRED		
ITEM	QUANTITY	NOTES
1	Side cutter.	1
2	2.5 mm Allen key.	1
The above list is not necessarily a complete list of all required tools and equipment needed. A calibrated torque wrench (with adequate range) and the correct size (as implied by the above tool list) accessories (sockets etc.) are implied for torquing bolts / nuts, if applicable. Refer to paragraph 1.5 for torque values.		
CONSUMABLE MATERIAL REQUIRED		
ITEM	QUANTITY	NOTES
1	Tie wraps.	2.
2	Loctite 222.	As needed. Instrument panel retaining screws.
The above list is not necessarily a complete list of all material needed. Refer to the Sling 2 construction manual.		
AUTHORISED PERSONNEL		
Any person performing maintenance of any kind on the aircraft or any component thereof must do so in accordance with national legislation. This is the responsibility of the aircraft owner and any person who is to perform any maintenance on the aircraft.		

**WARNING**  
**MASTER / IGNITION SWITCHES OFF.**

**CAUTION**  
**EFIS, EFIS BACK-UP AND ALL OTHER AVIONIC / INSTRUMENT SWITCHES OFF.**

### PROCEDURE (REMOVAL)

Retain any bolts, nuts (except lock-nuts) spacers, screws and washers (with the exception of lock-washers) for reassembly.

1. Undo the screws retaining the instrument panel and tilt it forward to gain access to the battery.
2. Unplug the electrical wires / lugs from the battery terminals.
3. Cut and remove the tie wraps retaining the battery to the bracket and fuselage frame and remove the battery.

### PROCEDURE (INSTALLATION)

1. Reverse the above procedure (removal), paying close attention to the following:
  - Inspect all bolts, nuts and screws for damage. Replace if necessary.
  - The battery is installed with its positive (red) terminal to the starboard side of the aircraft.
  - The battery is tie wrapped through both the holes in the bracket and the holes in the bulkhead, i.e. with two tie wraps which cross each other.



2. Inspect for security of attachment and for correct polarity of the connections before closing the instrument panel.
3. Apply thread locking sealant to the instrument panel mount screws before fitment.
4. Verify correct operation of the EFIS from the back-up battery alone, before flight.

### 10.3 ALTERNATOR MAINTENANCE

Servicing or repair of the alternator (AC generator) must be carried out by authorised personnel only.

### 10.4 REPLACEMENT OF CIRCUIT BREAKERS AND / OR SWITCHES

TOOLS / EQUIPMENT REQUIRED		
ITEM	QUANTITY	NOTES
1	9/16 Spanner.	Switches.
2	Phillips screwdriver or flat screwdriver.	Circuit breakers.
The above list is not necessarily a complete list of all required tools and equipment needed. A calibrated torque wrench (with adequate range) and the correct size (as implied by the above tool list) accessories (sockets etc.) are implied for torquing bolts / nuts, if applicable. Refer to paragraph 1.5 for torque values.		
CONSUMABLE MATERIAL REQUIRED		
ITEM	QUANTITY	NOTES
1	Loctite 222.	Instrument panel retaining screws.
The above list is not necessarily a complete list of all material needed. Refer to the Sling 2 construction manual.		
AUTHORISED PERSONNEL		
Any person performing maintenance of any kind on the aircraft or any component thereof must do so in accordance with national legislation. This is the responsibility of the aircraft owner and any person who is to perform any maintenance on the aircraft.		

#### WARNING

**ENSURE MASTER AND ELECTRICAL EQUIPMENT SWITCHES ARE OFF.  
IT MAY BE EXPEDIENT TO DISCONNECT THE BATTERY GROUND TERMINAL WHILE WORKING ON  
ELECTRICAL EQUIPMENT.**

#### CAUTION

**CIRCUIT BREAKERS AND / OR SWITCHES MUST BE REPLACED BY CIRCUIT BREAKERS AND / OR  
SWITCHES WITH IDENTICAL RATING AND SPECIFICATION.**

## PROCEDURE (CIRCUIT BREAKER)

1. Open the instrument panel (refer to paragraph 7.2).
2. Unscrew the wire / lug connecting terminals (1) on the circuit breaker (2) and remove the wires. Note (or mark) the placement / connection of the wires. Wires must be reconnected to the replacement circuit breaker in the same sense / order.
3. Undo the circuit breaker retaining nut / ring (3) and remove the circuit breaker and lock washer (4) from the instrument panel.
4. Slip the new washer (4) supplied with the circuit breaker over the circuit breaker threaded stub and inset the circuit breaker through the instrument panel. Ensure that the circuit breaker is inserted right side up. Align the circuit breaker body vertically and secure with the nut / ring (3). Do not over tighten.
5. Reattach the wires to the circuit breaker connecting terminals, in the same order / sense that they were fitted to the removed circuit breaker.
6. Inspect for security of attachment and correct connection.
7. Apply thread locking sealant to the instrument panel mount screws and close the instrument panel.



## PROCEDURE (SWITCH)

1. Open the instrument panel (refer to paragraph 7.2).
2. The electrical wiring connections from the switch connections (1). Note (or mark) the placement / connection of the wires. Wires must be reconnected to the replacement switch in the same sense / order.
3. Undo the front nut (2) securing the switch to the instrument panel and remove the switch.
4. Adjust the rear nut (3) on the replacement switch so that the switch body will be the correct distance behind the instrument panel when fitted / the switch will extend the correct distance in front of the instrument panel.
5. Ensure that the switch is inserted correct side up. Align the switch body vertically and secure with the front nut (3). Do not over tighten. PLEASE NOTE THAT IN CASES WHERE THE IGNITION (MAGNETO) SWITCHES ARE SEPARATE FROM THE KEY SWITCH, THE SWITCHES ARE MOUNTED UPSIDE DOWN, SO THAT THE IGNITION CIRCUITS ARE GROUNDED WHEN THE SWITCH LEVER IS DOWN.
6. Reattach the wires to the switch connecting terminals, in the same order that they were fitted to the removed switch.
8. Inspect for security of attachment and correct connection.
9. Apply power and test for correct operation.
10. Apply thread locking sealant to the instrument panel mount screws and close the instrument panel.

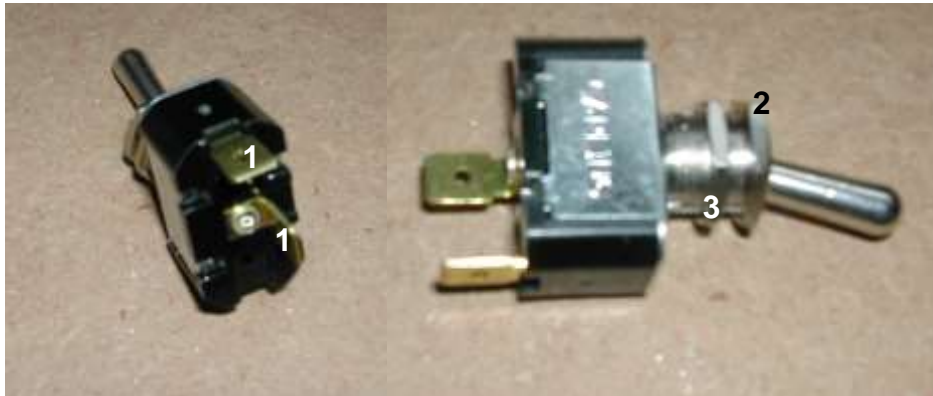

**10.5 REGULATOR / RECTIFIER REMOVAL AND REPLACEMENT**

TOOLS / EQUIPMENT REQUIRED		
ITEM	QUANTITY	NOTES
1	10 mm Socket.	1
2	Socket wrench + extension (if needed) for item 1.	1
<p>The above list is not necessarily a complete list of all required tools and equipment needed. A calibrated torque wrench (with adequate range) and the correct size (as implied by the above tool list) accessories (sockets etc.) are implied for torquing bolts / nuts, if applicable. Refer to paragraph 1.5 for torque values.</p>		
AUTHORISED PERSONNEL		
<p>Any person performing maintenance of any kind on the aircraft or any component thereof must do so in accordance with national legislation. This is the responsibility of the aircraft owner and any person who is to perform any maintenance on the aircraft.</p>		

**WARNING**

**ENSURE MASTER AND ELECTRICAL EQUIPMENT SWITCHES ARE OFF.**

**IT MAY BE EXPEDIENT TO DISCONNECT THE BATTERY GROUND TERMINAL WHILE WORKING ON ELECTRICAL EQUIPMENT.**

### PROCEDURE (REMOVAL)

Retain any bolts, nuts (except lock-nuts) spacers, screws and washers (with the exception of lock-washers) for reassembly.

1. Master switch OFF.
2. Disconnect the connection plug (1) from the rectifier (2).

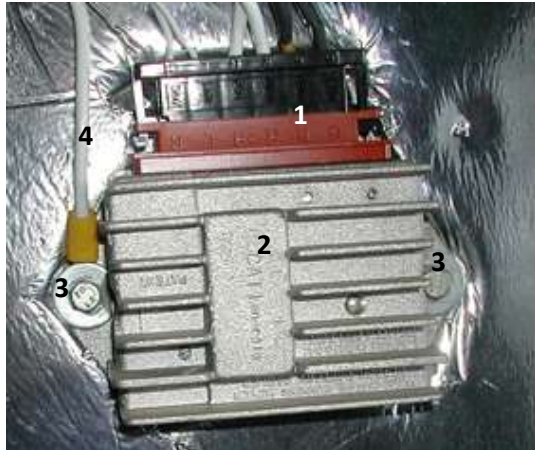

3. Undo the bolts (3) retaining the rectifier and the ground wire (4) to the firewall. Remove the rectifier.

### PROCEDURE (INSTALLATION)

1. Reverse the above procedure (removal) to install the regulator / rectifier, paying close attention to the following:
  - Tighten the mounting bolts sufficiently. Do not over tighten.

## 11. EXTERIOR LIGHTING

Exterior lighting consists of:

- Navigation lights.
- Landing and taxi lights.
- Strobe light.

### 11.1 NAVIGATION LIGHTS

Combined navigation and strobe lights are installed on the wing tips. All navigation lights are controlled by a single switch located on the instrument panel. Green, white and strobe lights are located on starboard wing tip. Red, white and strobe lights are located on the port wing tip.



**11.1.1 NAVIGATION LIGHT REMOVAL / INSTALLATION**

TOOLS / EQUIPMENT REQUIRED			
ITEM		QUANTITY	NOTES
1	2.5 mm Allen key / hex drive.	1	
The above list is not necessarily a complete list of all required tools and equipment needed. A calibrated torque wrench (with adequate range) and the correct size (as implied by the above tool list) accessories (sockets etc.) are implied for torquing bolts / nuts, if applicable. Refer to paragraph 1.5 for torque values.			
CONSUMABLE MATERIAL REQUIRED			
ITEM		QUANTITY	NOTES
1	Loctite 222.	As needed.	Navigation light retaining screws.
The above list is not necessarily a complete list of all material needed. Refer to the Sling 2 construction manual.			
AUTHORISED PERSONNEL			
Any person performing maintenance of any kind on the aircraft or any component thereof must do so in accordance with national legislation. This is the responsibility of the aircraft owner and any person who is to perform any maintenance on the aircraft.			

**WARNING**

**ENSURE MASTER AND NAVIGATION LIGHT SWITCHES ARE OFF.**

**IT MAY BE EXPEDIENT TO DISCONNECT THE BATTERY GROUND TERMINAL WHILE WORKING ON ELECTRICAL EQUIPMENT.**

### PROCEDURE (REMOVAL)

Retain any bolts, nuts (except lock-nuts) spacers, screws and washers (with the exception of lock-washers) for reassembly.

1. Master switch in OFF position. Navigation lights switch in OFF position.
2. Undo the button head screws retaining the navigation light to the wing.
3. Carefully move the light away from the wingtip until the wire connection plugs are revealed. Disconnect. Retain the rubber backing for reassembly.

### PROCEDURE (INSTALLATION)

1. Reverse the above procedure for reinstallation, paying close attention to the following:
  - Inspect all bolts, nuts and screws for damage. Replace if necessary.
  - Inspect the rubber backing for damage before fitting. Replace if necessary.
  - Apply thread locking sealant to the navigation light retaining screws before fitment. Do not over tighten.
2. Apply electrical power and verify correct operation of the lights.

## 11.2 LANDING AND TAXI LIGHTS

A landing light is located in each wing leading edge. The landing lights are activated by a switch located on the instrument panel. A taxi light is located in each wing leading edge. The taxi lights are activated by a switch located on the instrument panel.

### 11.2.1 LANDING AND / OR TAXI LIGHT REMOVAL / INSTALLATION

TOOLS / EQUIPMENT REQUIRED			
ITEM		QUANTITY	NOTES
1	2.5 mm Allen key / hex driver.	1	
2	Phillips screwdriver.	1	
3	Heat gun.	1	
The above list is not necessarily a complete list of all required tools and equipment needed. A calibrated torque wrench (with adequate range) and the correct size (as implied by the above tool list) accessories (sockets etc.) are implied for torquing bolts / nuts, if applicable. Refer to paragraph 1.5 for torque values.			
CONSUMABLE MATERIAL REQUIRED			
ITEM		QUANTITY	NOTES
1	9.5 mm Heat shrink.	As needed.	
The above list is not necessarily a complete list of all material needed. Refer to the Sling 2 construction manual.			
AUTHORISED PERSONNEL			
Any person performing maintenance of any kind on the aircraft or any component thereof must do so in accordance with national legislation. This is the responsibility of the aircraft owner and any person who is to perform any maintenance on the aircraft.			

#### WARNING

**ENSURE MASTER AND LANDING / TAXI LIGHT SWITCHES ARE OFF.**

**IT MAY BE EXPEDIENT TO DISCONNECT THE BATTERY GROUND TERMINAL WHILE WORKING ON ELECTRICAL EQUIPMENT**

## PROCEDURE (REMOVAL)

Retain any bolts, nuts (except lock-nuts) spacers, screws and washers (with the exception of lock-washers) for reassembly.

1. Master switch in OFF position. Landing light and taxi light switches in OFF positions.
2. Undo the screws retaining the clear lens to the wing and remove the lens.
3. Undo the button head screws (1) which secure the taxi (2) or landing (3) light and remove together with the tension springs. Retain the springs for reassembly. Slowly move the light away from the mounting bracket, until the electric wire connectors are exposed.

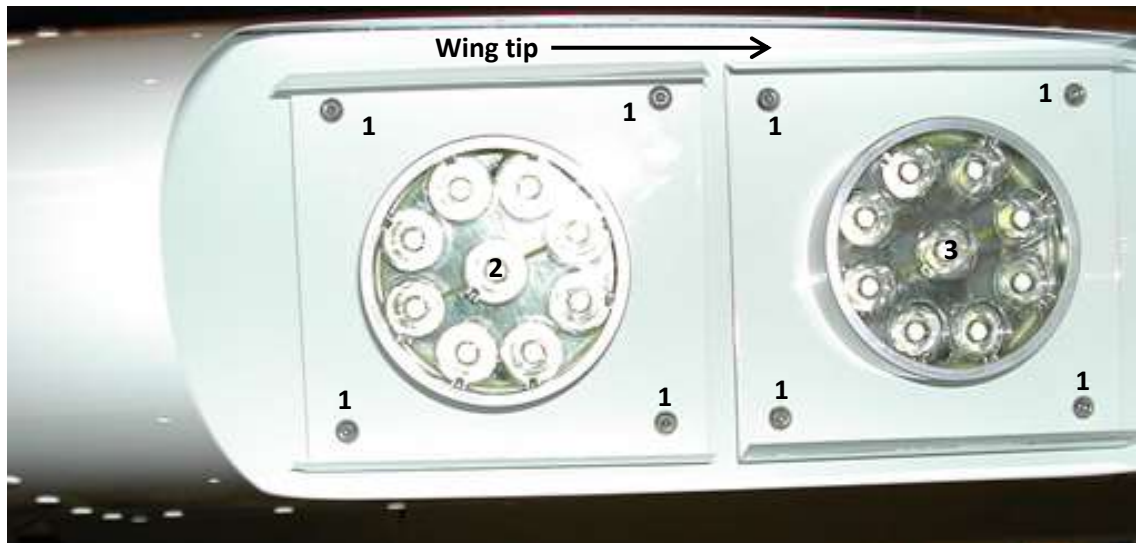

4. Remove the heat shrink from the connectors and disconnect.

## PROCEDURE (INSTALLATION)

1. Reverse the above procedure (removal) for installation, paying close attention to the following:
  - Inspect all bolts and / or screws for damage. Replace if necessary.
  - The light assembly is installed on the wing with the red wire (wired into the circular extension on the light itself) facing towards the top of the wing.

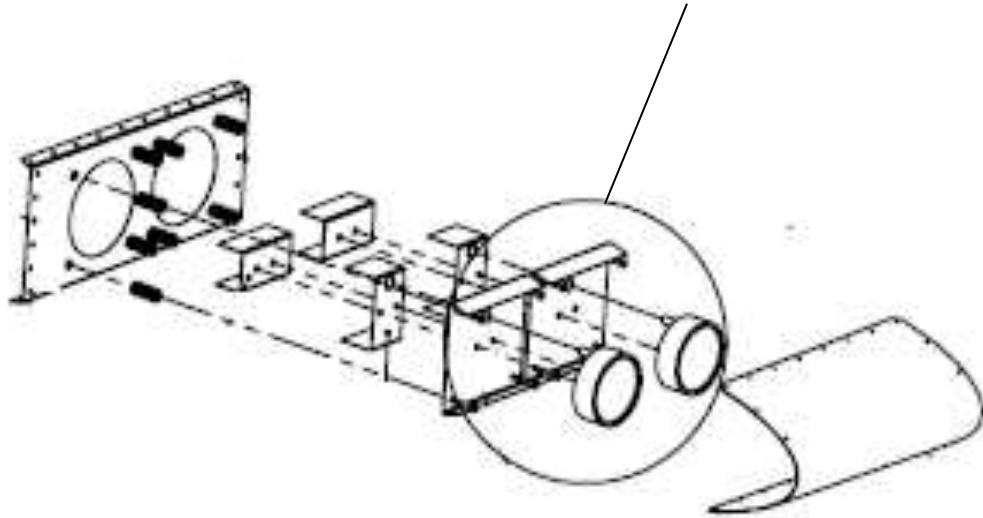

Figure 74 : Landing and taxi light installation.

- All connector connections must be covered by heat shrink (see below). Slide heat shrink over the wires before connecting the connectors together. Slide back over the connected connectors and shrink with a suitable heat source (e.g. a heat gun). Do not melt / burn the heat shrink.



2. Adjust the light (refer to paragraph 11.2.3).
3. Apply electrical power and verify for correct operation of the light and correct adjustment.
4. Inspect for security of attachment before replacing the clear lens.

**11.2.2 LANDING AND / OR TAXI LIGHT REPLACEMENT**

TOOLS / EQUIPMENT REQUIRED		
ITEM	QUANTITY	NOTES
1	3/8 Spanner.	1
<p>The above list is not necessarily a complete list of all required tools and equipment needed. A calibrated torque wrench (with adequate range) and the correct size (as implied by the above tool list) accessories (sockets etc.) are implied for torquing bolts / nuts, if applicable. Refer to paragraph 1.5 for torque values.</p>		
CONSUMABLE MATERIAL REQUIRED		
ITEM	QUANTITY	NOTES
1	Tie wraps.	As needed.
<p>The above list is not necessarily a complete list of all material needed. Refer to the Sling 2 construction manual.</p>		
AUTHORISED PERSONNEL		
<p>Any person performing maintenance of any kind on the aircraft or any component thereof must do so in accordance with national legislation. This is the responsibility of the aircraft owner and any person who is to perform any maintenance on the aircraft.</p>		

## PROCEDURE (DISASSEMBLY)

Retain any bolts, nuts (except lock-nuts) spacers, screws and washers (with the exception of lock-washers) for reassembly.

1. Remove the light assembly from the aircraft (refer to paragraph 11.2.1).
2. Undo the nuts (1) retaining the light to the angled plates (2), front plate (3) and ground wire (4). Cut tie wraps. Remove the light.

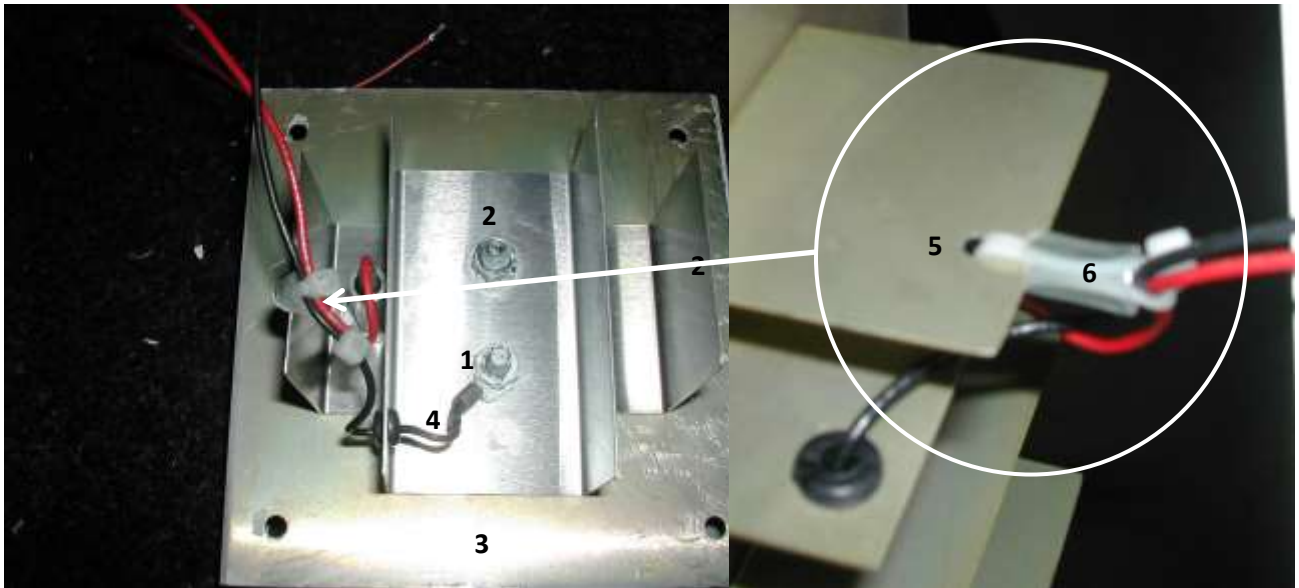

## PROCEDURE (ASSEMBLY)

1. Reverse the above procedure (disassembly), paying careful attention to the following:
  - Observe correct orientation of the angled plates. Also refer to Figure 74.
  - Tie wrap the wires together and to the angled plates (through hole (5)) with a plastic tubular standoff / spacer (6) to distance the wires from the angled plate's edge.
  - Inspect the light for any sign of damage before assembling.

**11.2.3 LANDING AND / OR TAXI LIGHT ADJUSTMENT**

TOOLS / EQUIPMENT REQUIRED		
ITEM	QUANTITY	NOTES
1	2.5 mm Allen key / hex driver.	1
2	Phillips screwdriver.	1
<p>The above list is not necessarily a complete list of all required tools and equipment needed. A calibrated torque wrench (with adequate range) and the correct size (as implied by the above tool list) accessories (sockets etc.) are implied for torquing bolts / nuts, if applicable. Refer to paragraph 1.5 for torque values.</p>		
AUTHORISED PERSONNEL		
<p>Any person performing maintenance of any kind on the aircraft or any component thereof must do so in accordance with national legislation. This is the responsibility of the aircraft owner and any person who is to perform any maintenance on the aircraft.</p>		

**PROCEDURE**

1. Undo the screws retaining the clear lens to the wing and remove the lens.
2. Adjust the light angle in azimuth and elevation by independently adjusting each button head screw until the desired result is attained.
3. Replace the lens.



### 11.3 STROBE LIGHT

A strobe light is installed on the rudder horn. The strobe light is activated by a switch located on the instrument panel.

#### 11.3.1 STROBE LIGHT REMOVAL / INSTALLATION

TOOLS / EQUIPMENT REQUIRED		
ITEM	QUANTITY	NOTES
1	2.5 mm Allen key / hex drive.	1
The above list is not necessarily a complete list of all required tools and equipment needed. A calibrated torque wrench (with adequate range) and the correct size (as implied by the above tool list) accessories (sockets etc.) are implied for torquing bolts / nuts, if applicable. Refer to paragraph 1.5 for torque values.		
CONSUMABLE MATERIAL REQUIRED		
ITEM	QUANTITY	NOTES
1	Loctite 222.	As needed
Strobe light retaining screws.		
The above list is not necessarily a complete list of all material needed. Refer to the Sling 2 construction manual.		
AUTHORISED PERSONNEL		
Any person performing maintenance of any kind on the aircraft or any component thereof must do so in accordance with national legislation. This is the responsibility of the aircraft owner and any person who is to perform any maintenance on the aircraft.		

**WARNING**

**ENSURE MASTER AND STROBE LIGHT SWITCHES ARE OFF.  
IT MAY BE EXPEDIENT TO DISCONNECT THE BATTERY GROUND TERMINAL WHILE WORKING ON  
ELECTRICAL EQUIPMENT.**

### PROCEDURE (REMOVAL)

Retain any bolts, nuts (except lock-nuts) spacers, screws and washers (with the exception of lock-washers) for reassembly.

1. Master switch in OFF position. Strobe light switch in OFF position.
2. Undo the button head screws retaining the strobe light to the wing.
3. Carefully move the light away from the rudder until the wire connection plugs are revealed. Disconnect.

### PROCEDURE (INSTALLATION)

1. Reverse the above procedure for reinstallation, paying close attention to the following:
  - Inspect all bolts, nuts and screws for damage. Replace if necessary.
  - Apply thread locking sealant to the strobe light retaining screws before fitment. Do not over tighten.
2. Apply electrical power and verify correct operation of the strobe light. Testing of the strobe light may have to be done with the engine running, since the battery may or may not have enough voltage to energize the light.

## **12. EMERGENCY AND SAFETY SYSTEMS**

### **12.1 BALLISTIC PARACHUTE**

The Sling 2 and Sling LSA are designed specifically for convenient fitment of a Magnum 601 ballistic parachute recovery system. The system is designed to enable the pilot or passenger to deploy the parachute in case of emergency, in such a manner that the aircraft structure is carried under the parachute to the ground, on the basis that the occupants will not be injured and the aircraft structure suffers minimal damage.

#### **12.1.1 GENERAL SERVICE AND MAINTENANCE.**

The ballistic parachute should be serviced by qualified personnel only.

Refer to paragraph 3.3.2.

## 12.2 SAFETY HARNESES

The aircraft is fitted with a lap and shoulder strap safety harness for each occupant. The lap strap brackets (one for each half of the lap strap) are attached next to the seat, to the fuselage side and inside the centre console. The shoulder strap(s) bracket for each harness is attached to the cargo / luggage area rear bulkhead.

### 12.2.1 REMOVAL / INSTALLATION OF SAFETY BELT(S)

TOOLS / EQUIPMENT REQUIRED		
ITEM	QUANTITY	NOTES
1	7/16 Spanner.	2
The above list is not necessarily a complete list of all required tools and equipment needed. A calibrated torque wrench (with adequate range) and the correct size (as implied by the above tool list) accessories (sockets etc.) are implied for torquing bolts / nuts, if applicable. Refer to paragraph 1.5 for torque values.		
AUTHORISED PERSONNEL		
Any person performing maintenance of any kind on the aircraft or any component thereof must do so in accordance with national legislation. This is the responsibility of the aircraft owner and any person who is to perform any maintenance on the aircraft.		

#### CAUTION

**BE PREPARED WITH A HELPER OR SUPPORT STAND TO HANDLE THE WEIGHT AND / OR AWKWARDNESS OF THE OBJECT (SEAT) TO BE REMOVED / INSTALLED.**

## PROCEDURE (REMOVAL)

Retain any bolts, spacers, nuts (except lock-nuts) screws and washers (with the exception of lock-washers) for reassembly.

1. Remove the seat (refer to paragraph 4.3.2.1) on the side of the safety harness to be removed.
2. Undo the bolt (inside the centre console) retaining the lap strap to the fuselage and remove the belt / strap.
3. Undo the bolt (1) and nut (2) retaining the lap strap bracket to the fuselage side and remove the lap strap.

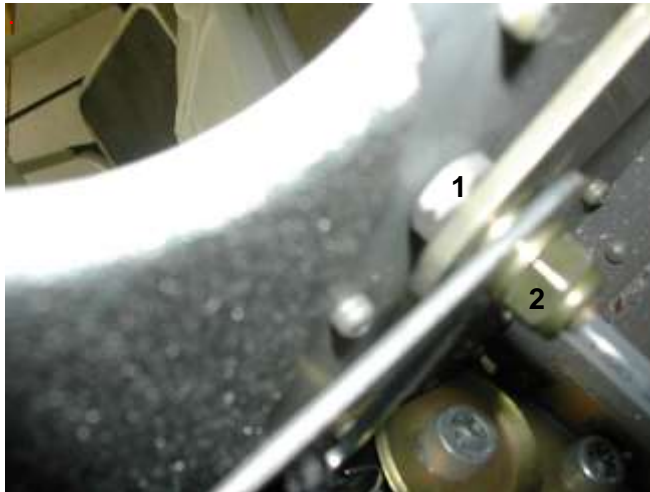

4. Undo the nut and bolt (3) retaining the shoulder strap(s) to the cargo / luggage compartment rear bulkhead and remove the strap(s).



## PROCEDURE (INSTALLATION)

1. Reverse the above procedure for reinstallation, paying close attention to the following:
  - Inspect all bolts, nuts and screws for damage. Replace if necessary.
  - Do not reuse lock-nuts. Fit new.
  
2. Inspect the entire length of the safety harness canvas for damage before fitment.

**13. APPENDIX A (AVIONICS AND ELECTRICAL SYSTEM WIRING DIAGRAMS)**

**13.1 CHARGE AND START SYSTEM / FUEL PUMPS WIRING DIAGRAM (914 UL)**

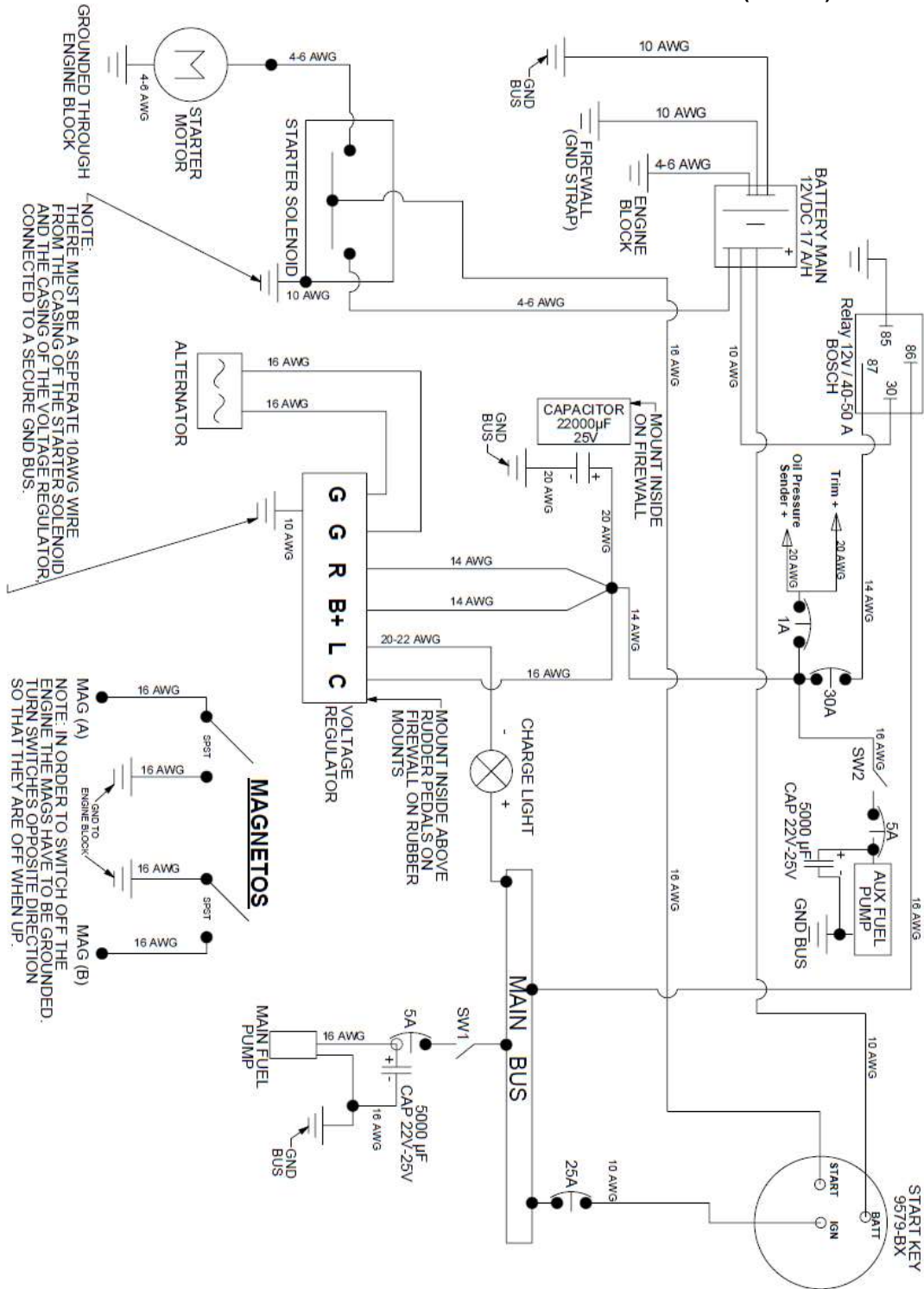

Figure 75: Charge and start system wiring diagram /fuel pump wiring (914 ULS)

**13.2 CHARGE AND START SYSTEM / FUEL PUMPS WIRING DIAGRAM (912 ULS)**

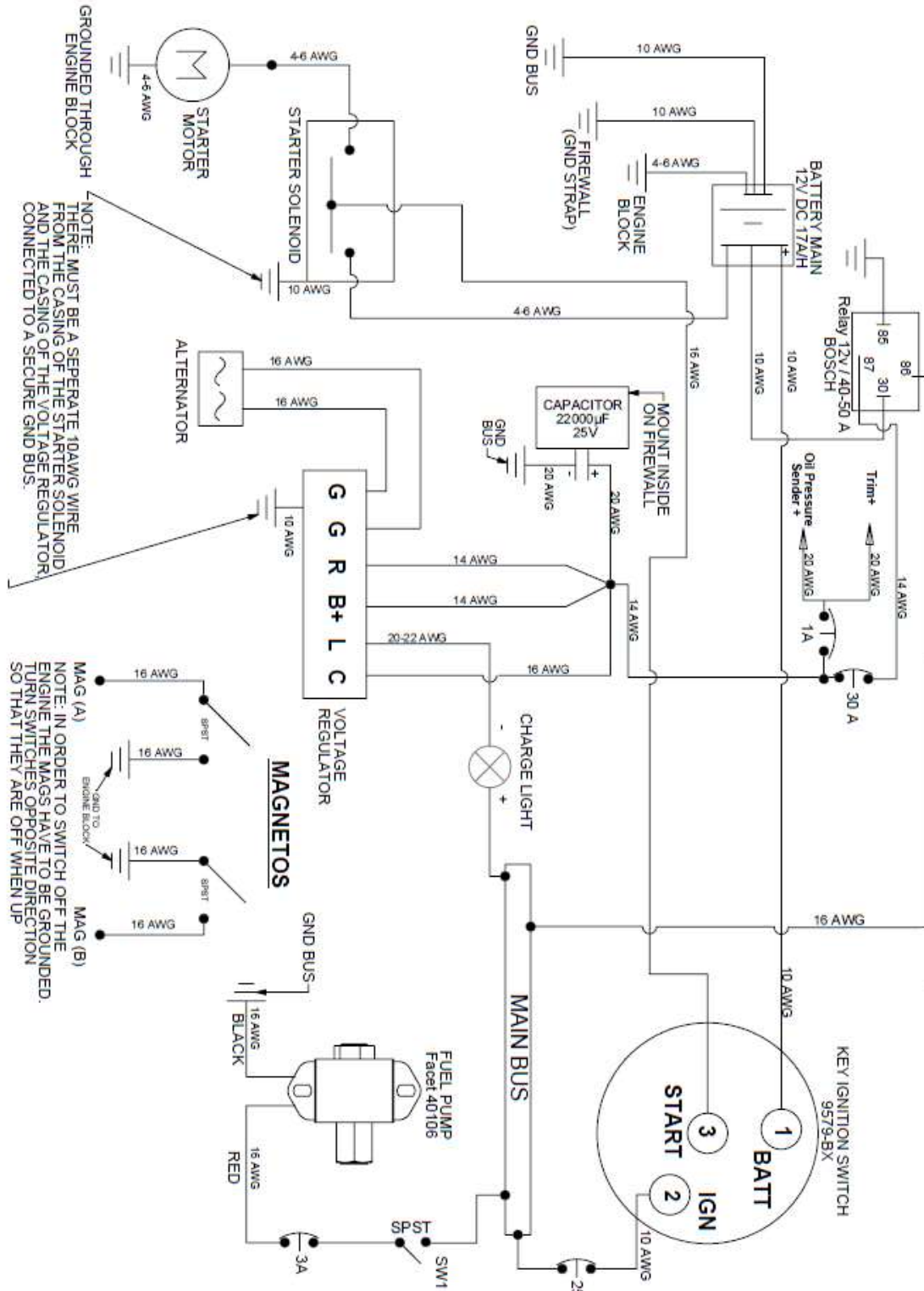

Figure 76: Charge and start system wiring diagram /fuel pump wiring (912 ULS).



13.3 EXTERNAL ALTERNATOR WIRING DIAGRAM (914 UL / 912 ULS)

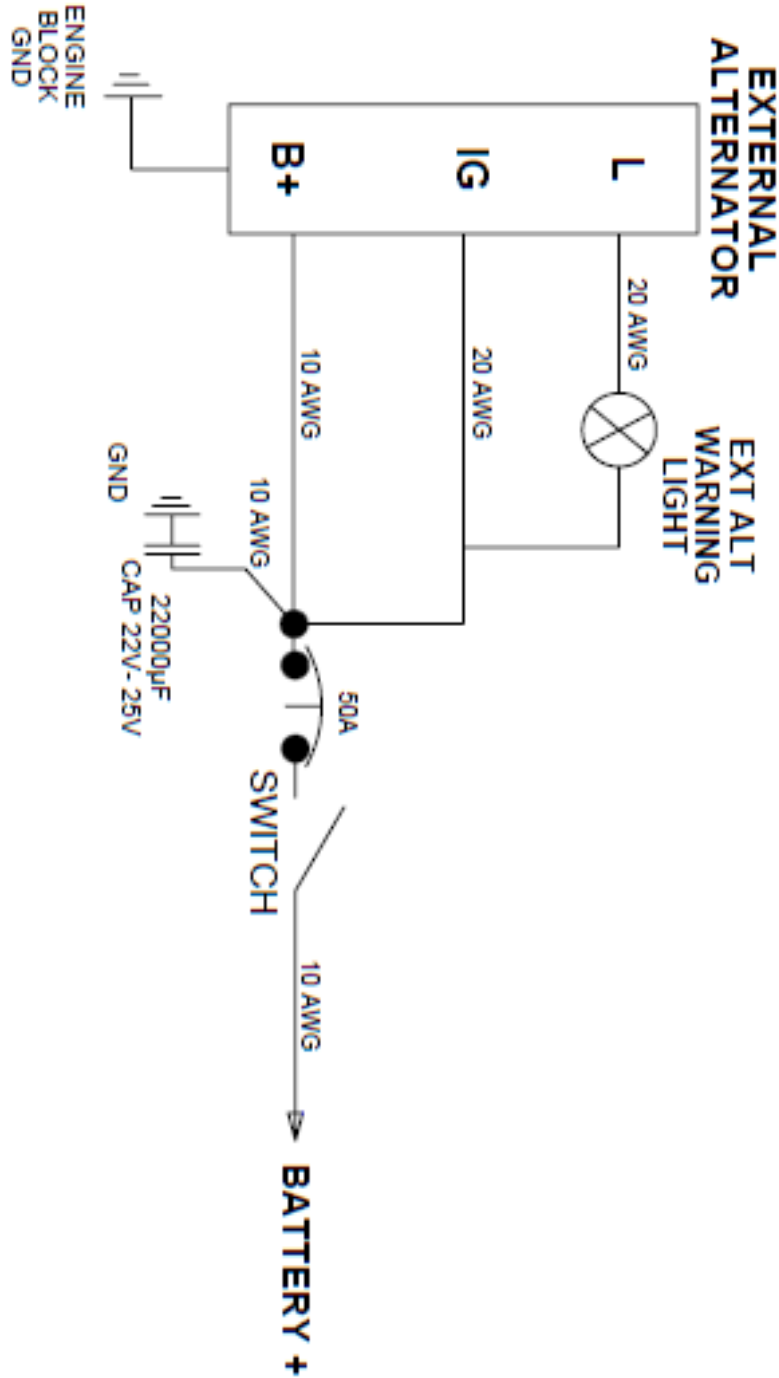

Figure 77: External alternator wiring diagram (914 UL / 912 ULS).

**13.4 ELECTRICAL SYSTEM / FUEL PUMPS WIRING DIAGRAM (912 IS)**

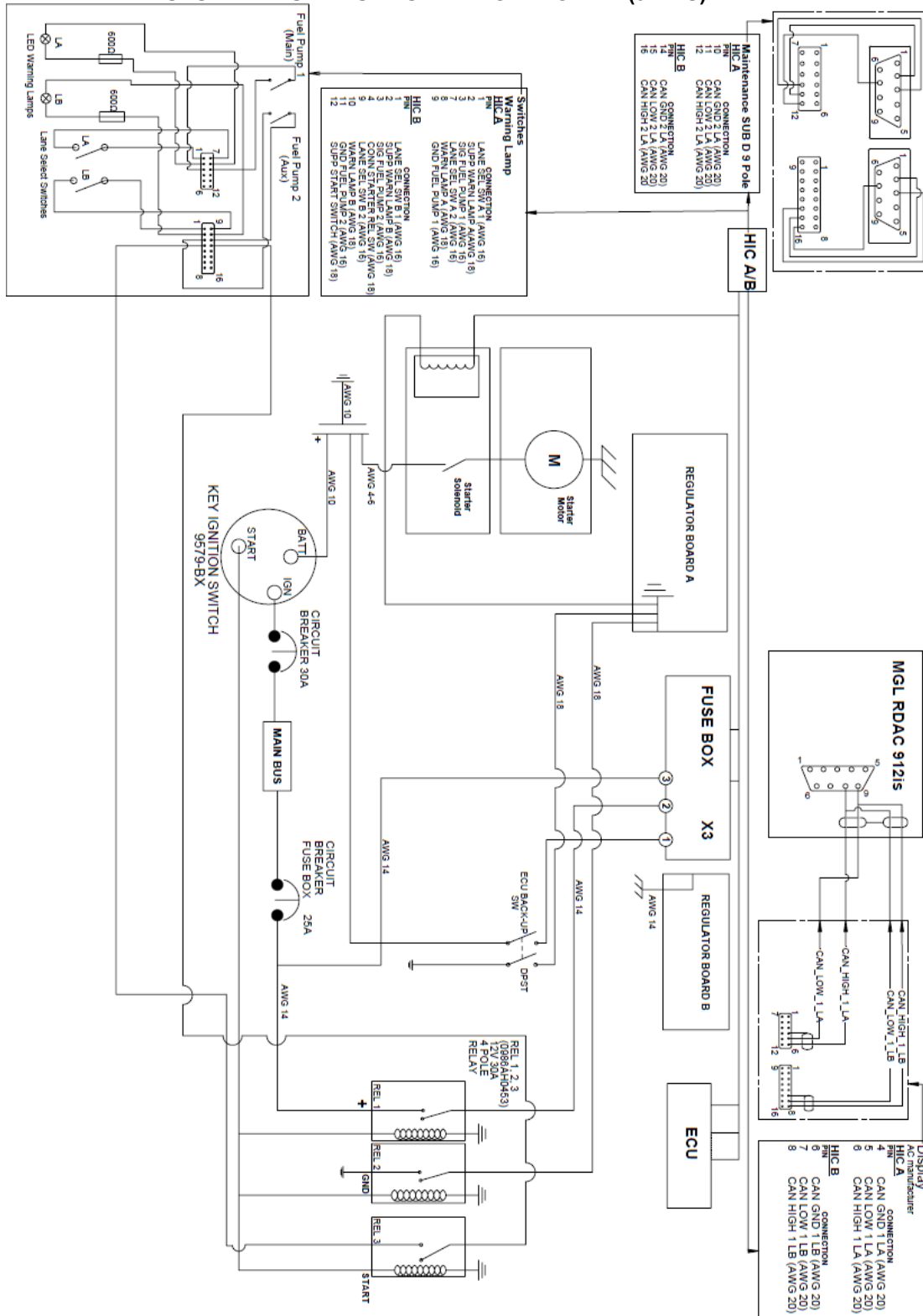

Figure 78: 912 iS electrical wiring diagram.

13.5 SWITCHES AND CIRCUIT BREAKERS WIRING DIAGRAM (914 UL)

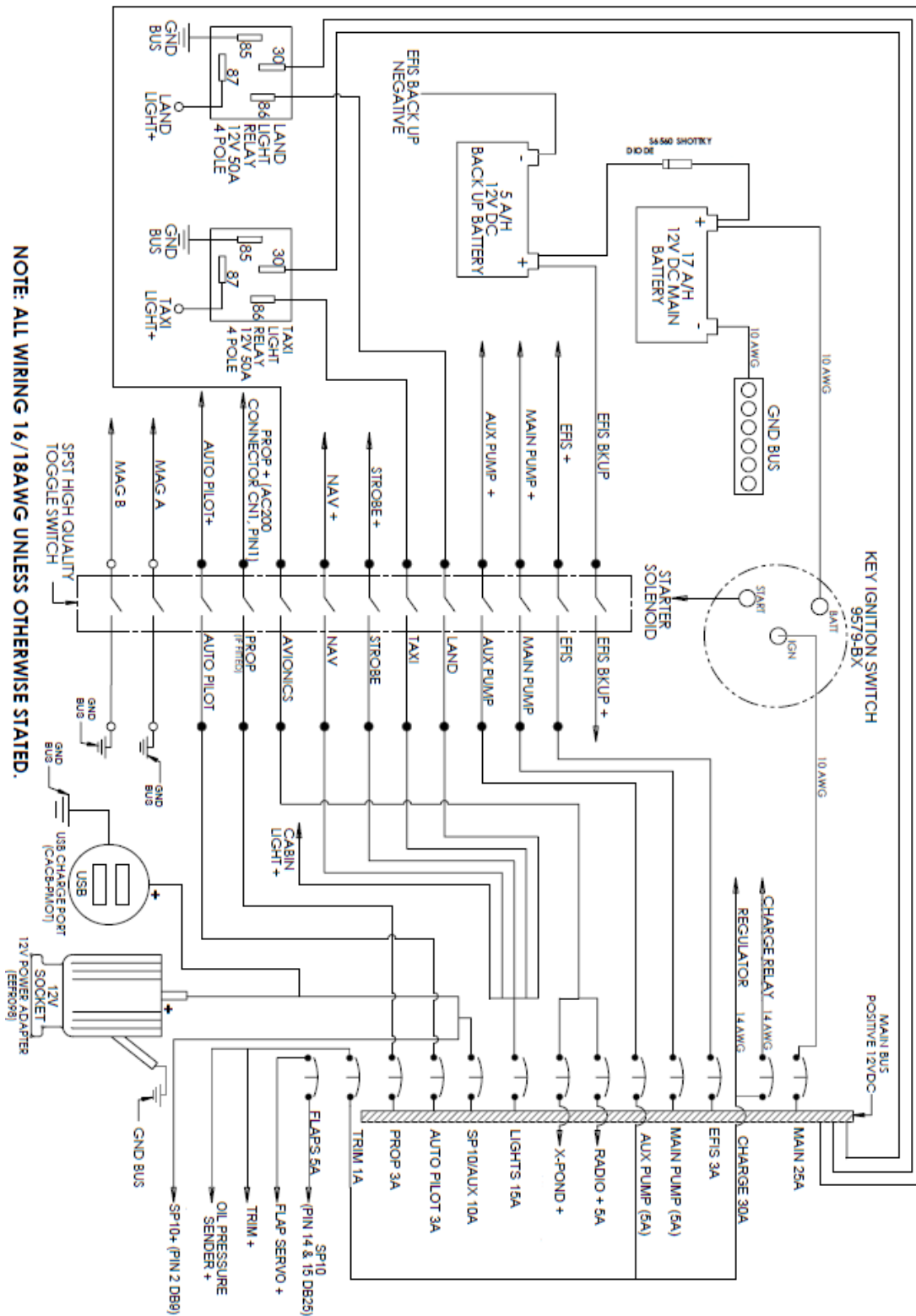

Figure 79: Switches and circuit breakers wiring diagram (914 UL).

**13.6 SWITCHES AND CIRCUIT BREAKERS WIRING DIAGRAM (912 ULS)**

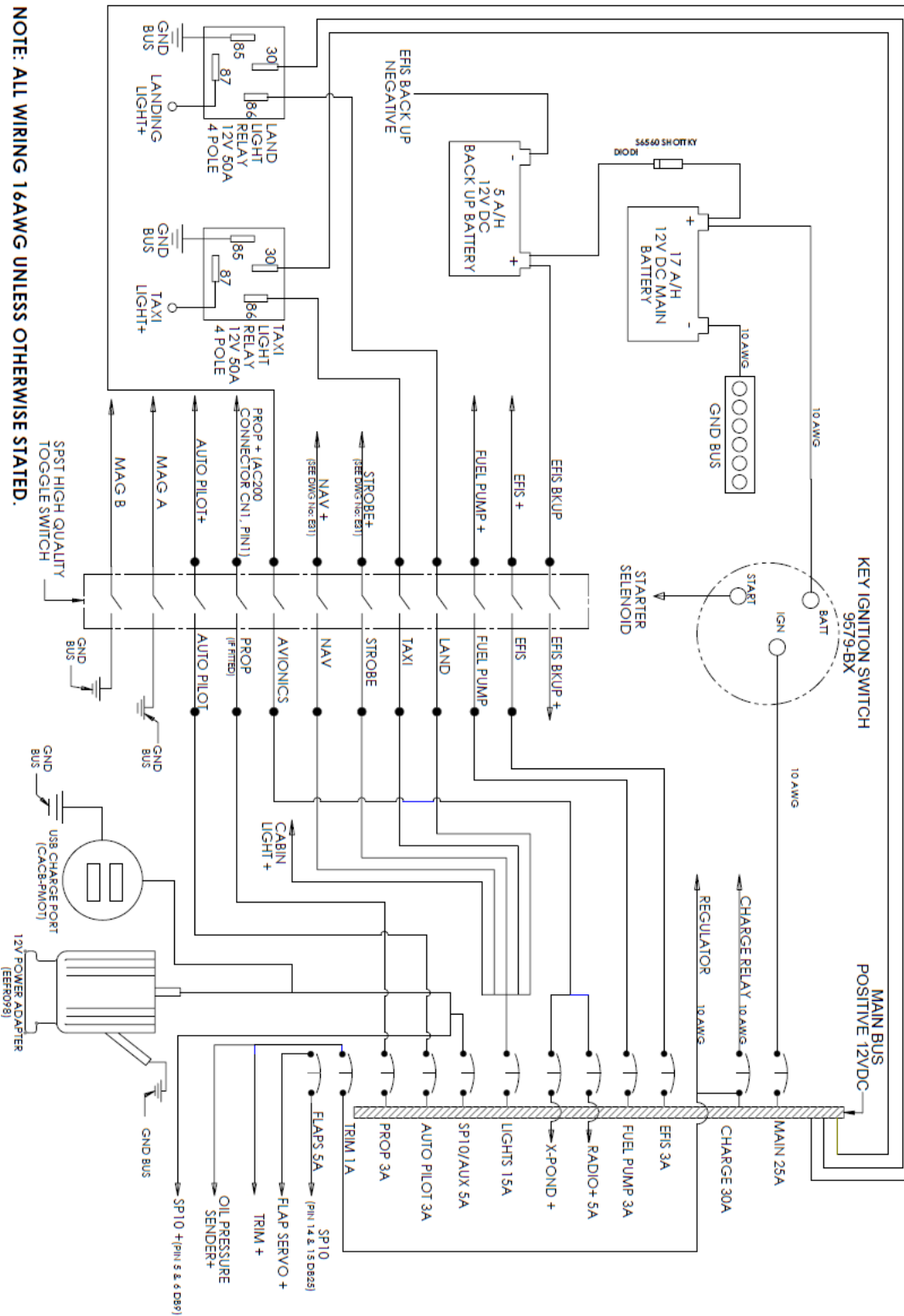

Figure 80: Switches and circuit breakers wiring diagram (912 ULS).

**13.7 SWITCHES AND CIRCUIT BREAKERS WIRING DIAGRAM (912 IS)**

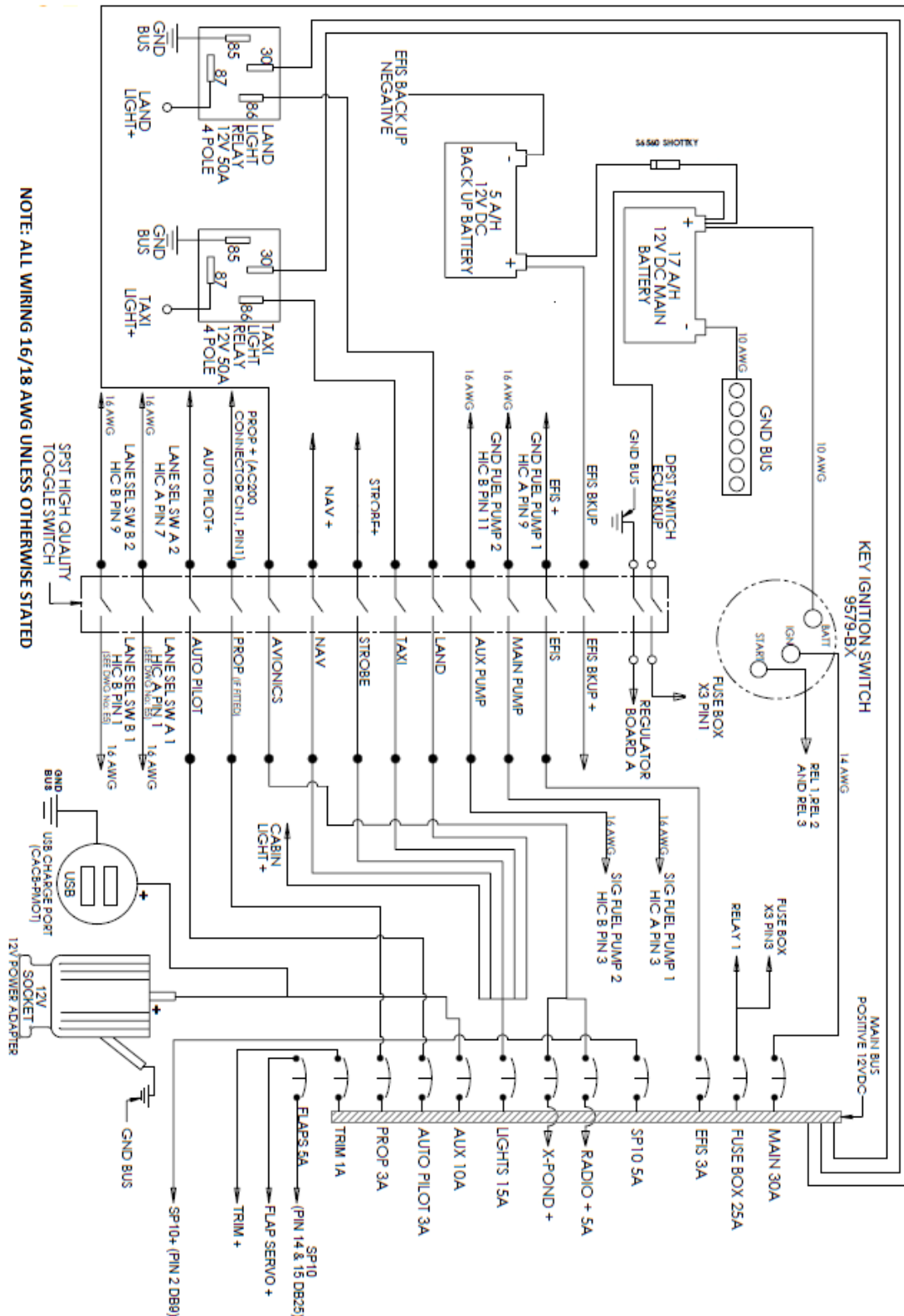

Figure 81: Switches and circuit breakers wiring diagram (912 iS).

### 13.8 FLAP SYSTEM WIRING DIAGRAM

#### 13.8.1 MGL SP10 FLAP CONTROL WITH 4 POSITION ROTARY SWITCH

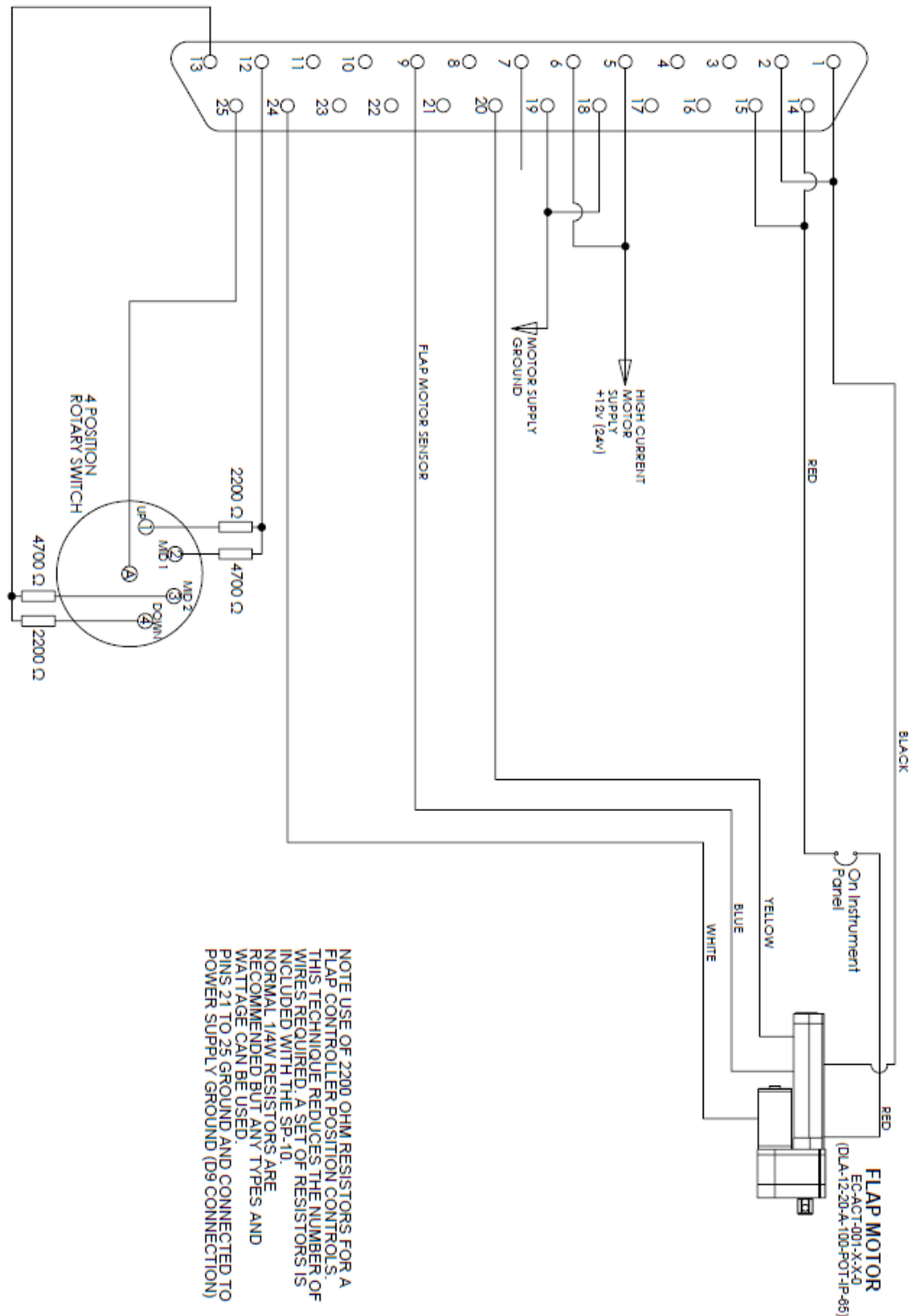

Figure 82: MGL SP10 flap controller.

13.8.2 INOTEC FLAP SYSTEM

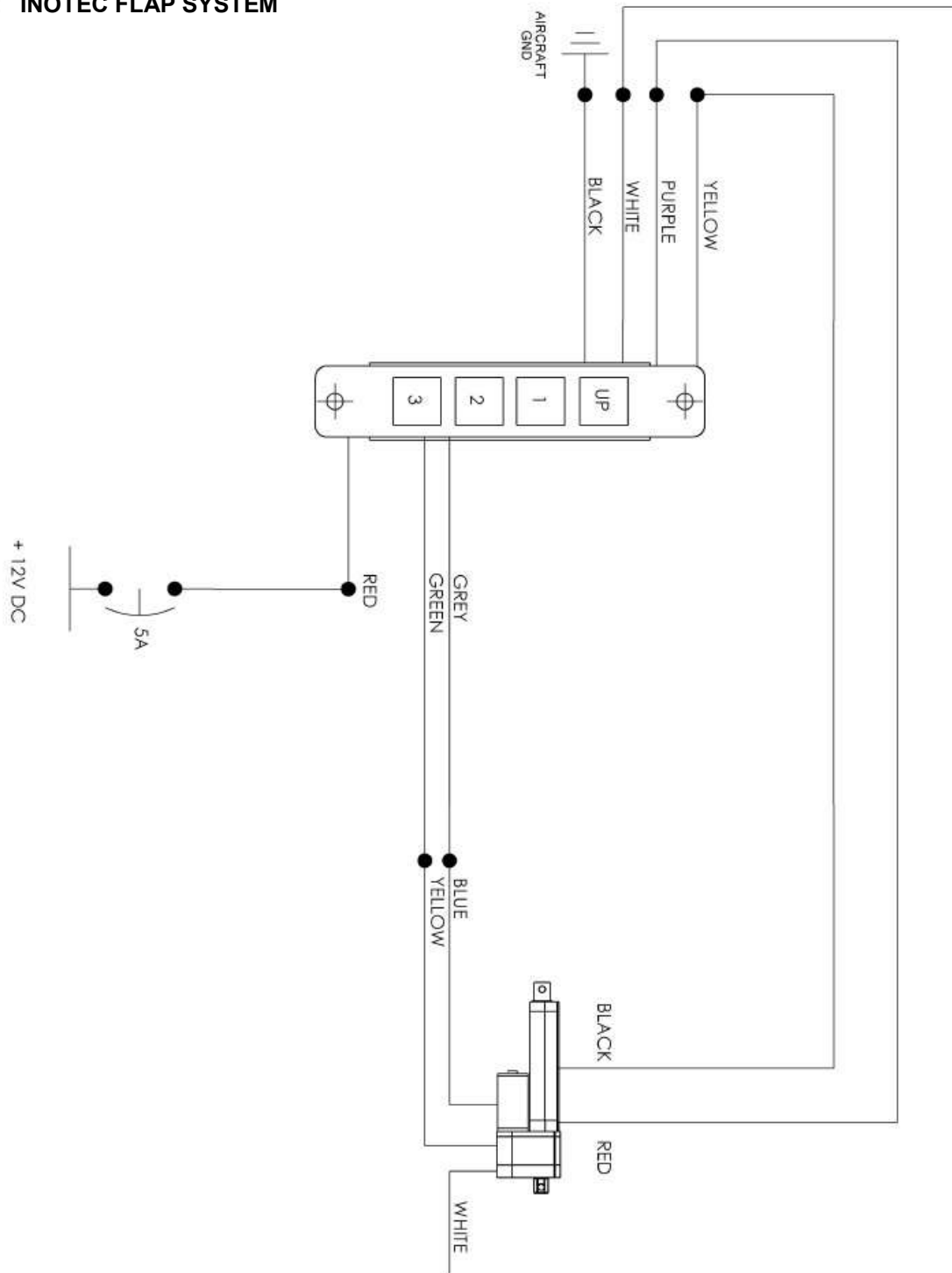

Figure 83: Flap system wiring diagram – INOTEC.

### 13.8.3 E-FLAPS

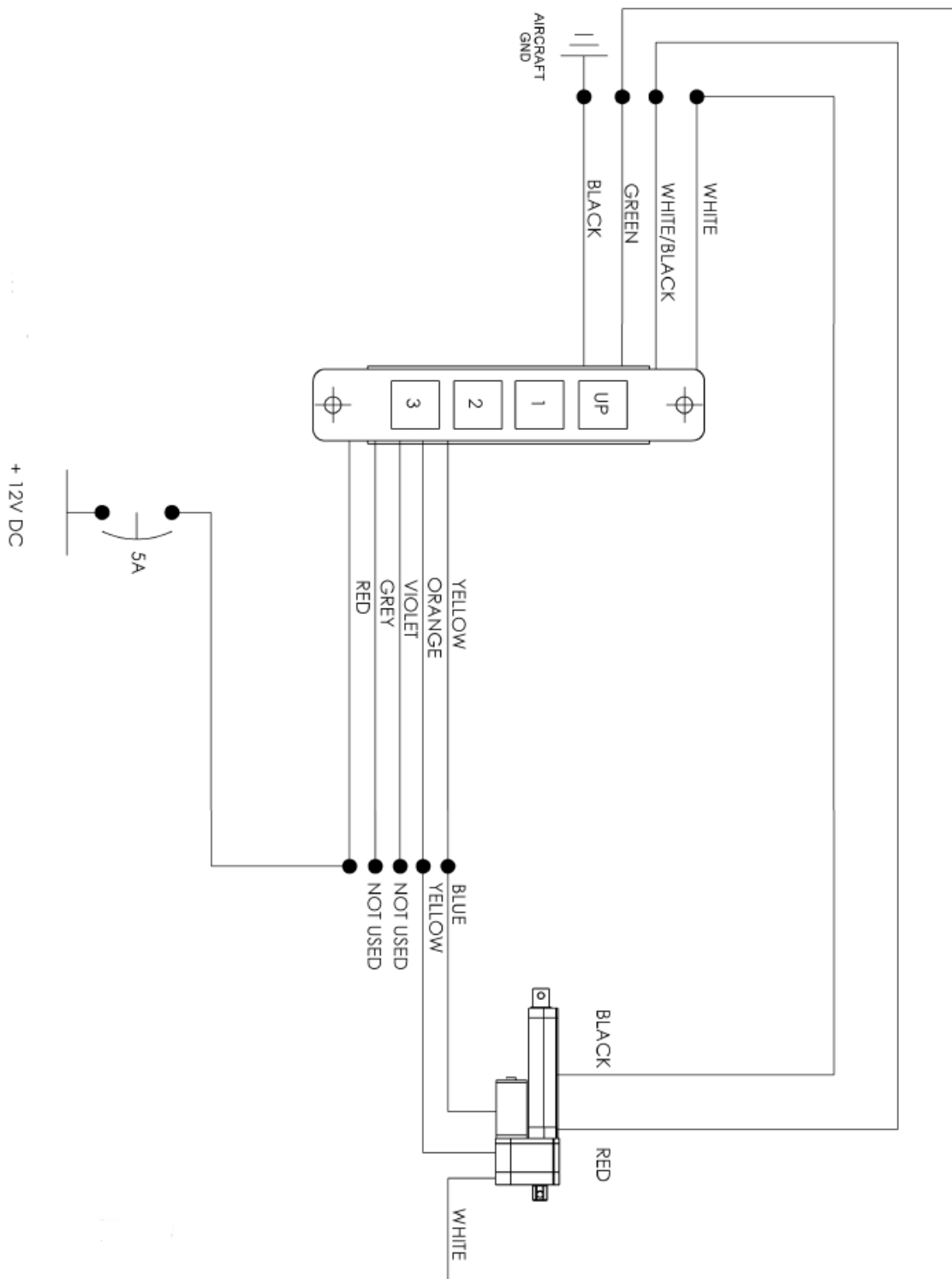

Figure 84: Flap system wiring diagram - E-Flaps.



### 13.9 ELEVATOR TRIM MOTOR WIRING DIAGRAM

#### 13.9.1 DUAL STICK TRIM

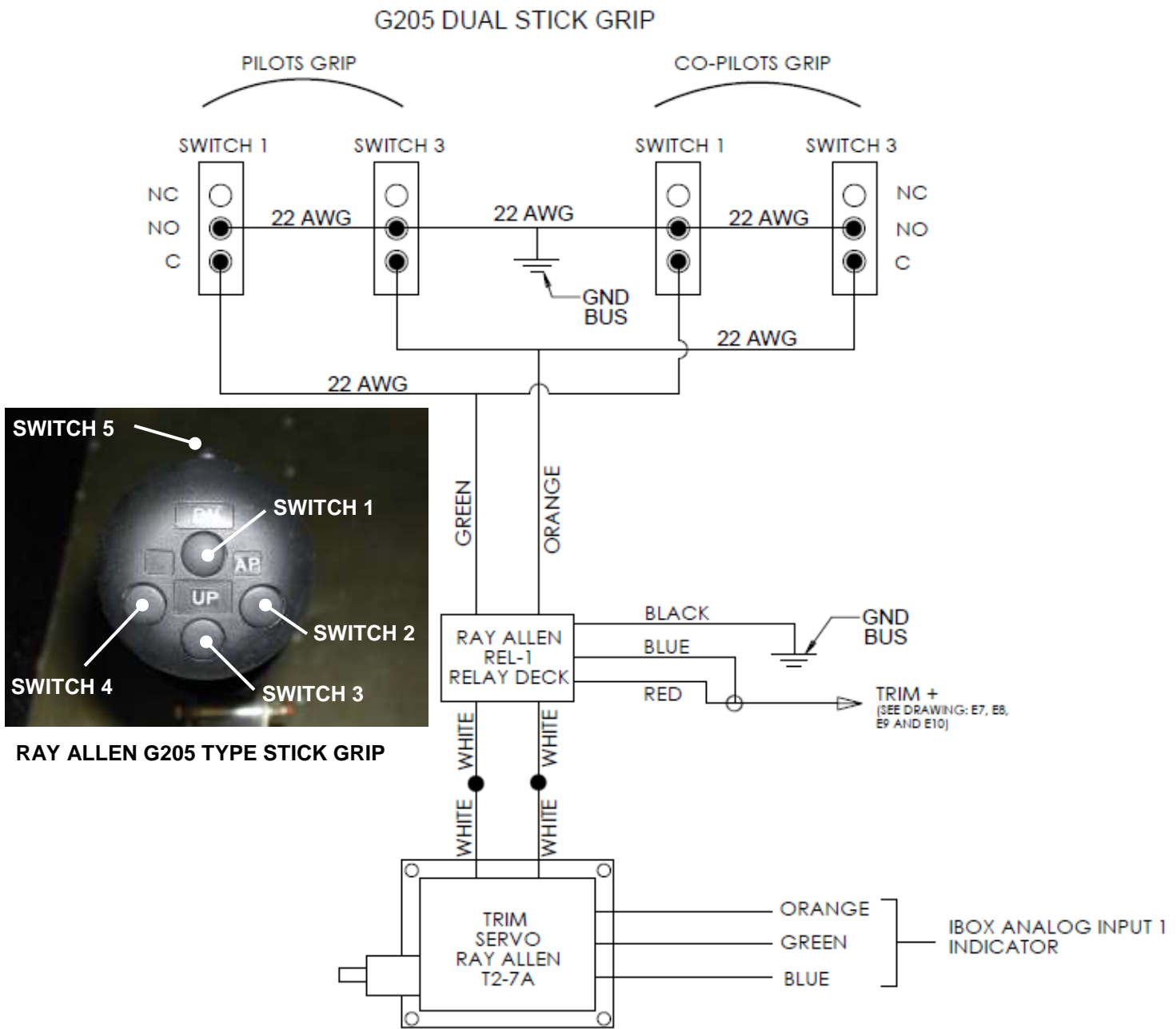

Figure 85: Elevator trim motor wiring diagram – dual control sticks.

### 13.9.2 SINGLE STICK TRIM

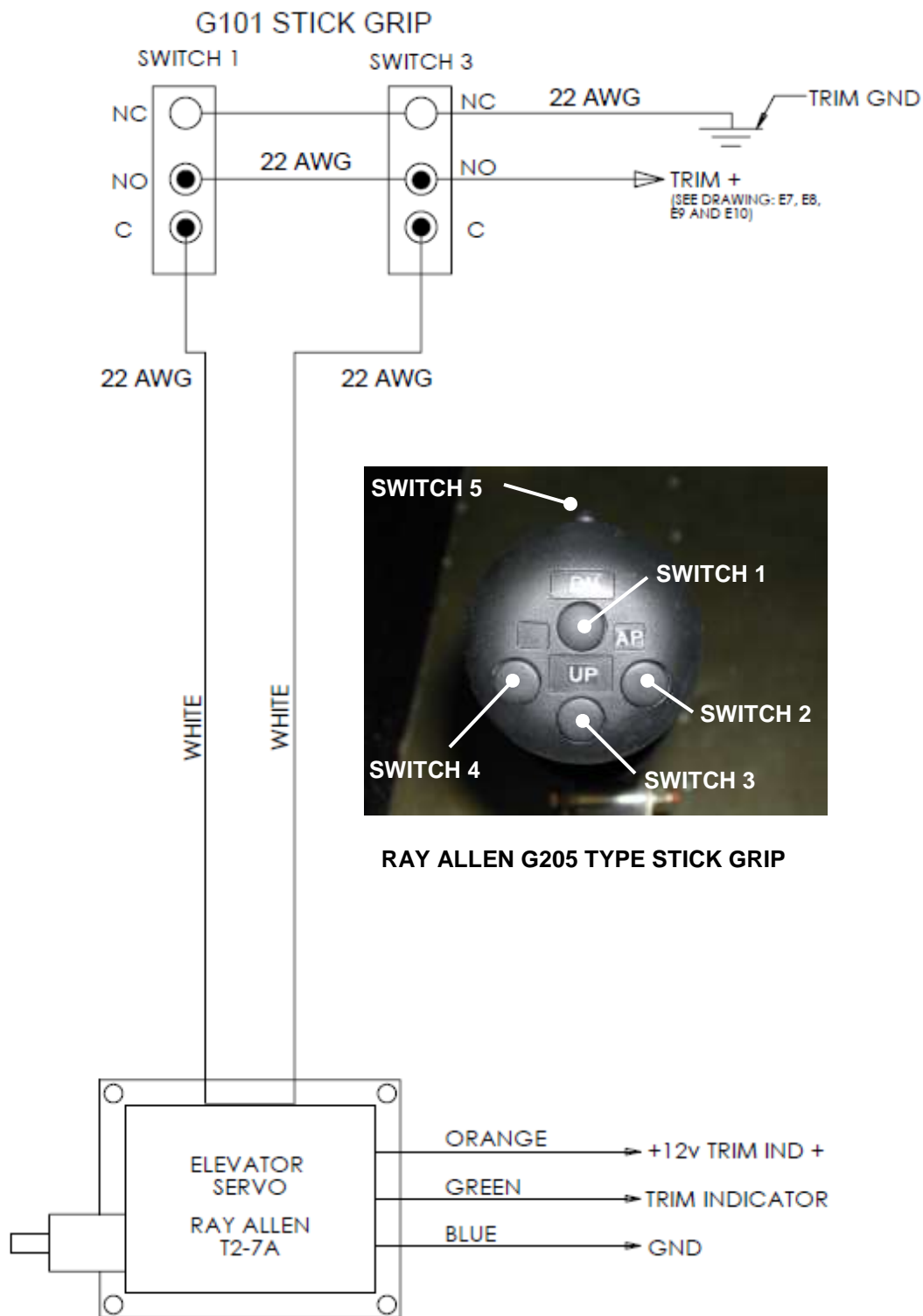

Figure 86: Elevator trim motor wiring diagram – single control stick.

13.10 EFIS SYSTEM / COMMUNICATIONS BUS LAYOUT

13.10.1 912 IS INSTALLATION

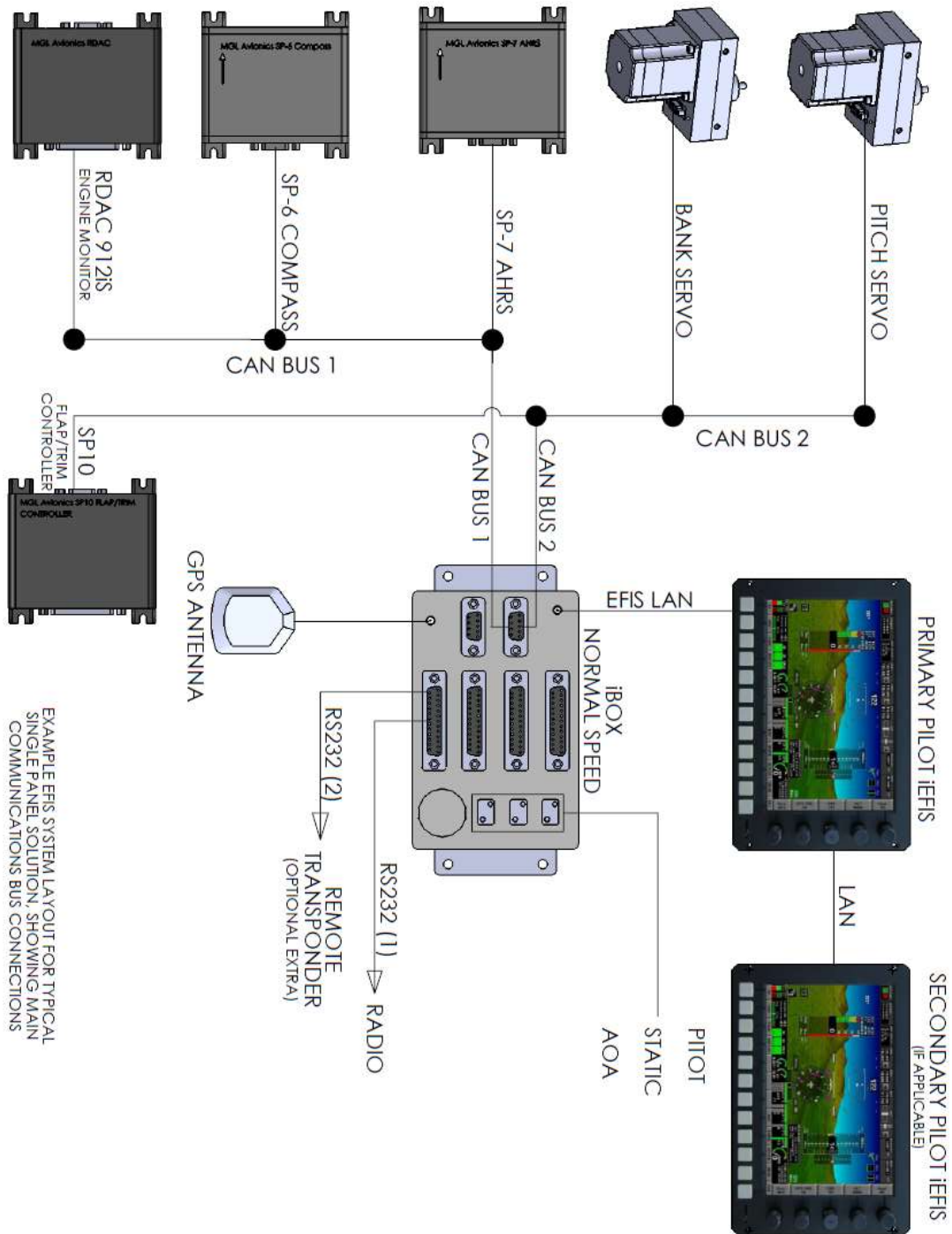

Figure 87: EFIS system / communications bus layout - 912 iS.

13.10.2 914 UL / 912 ULS INSTALLATION

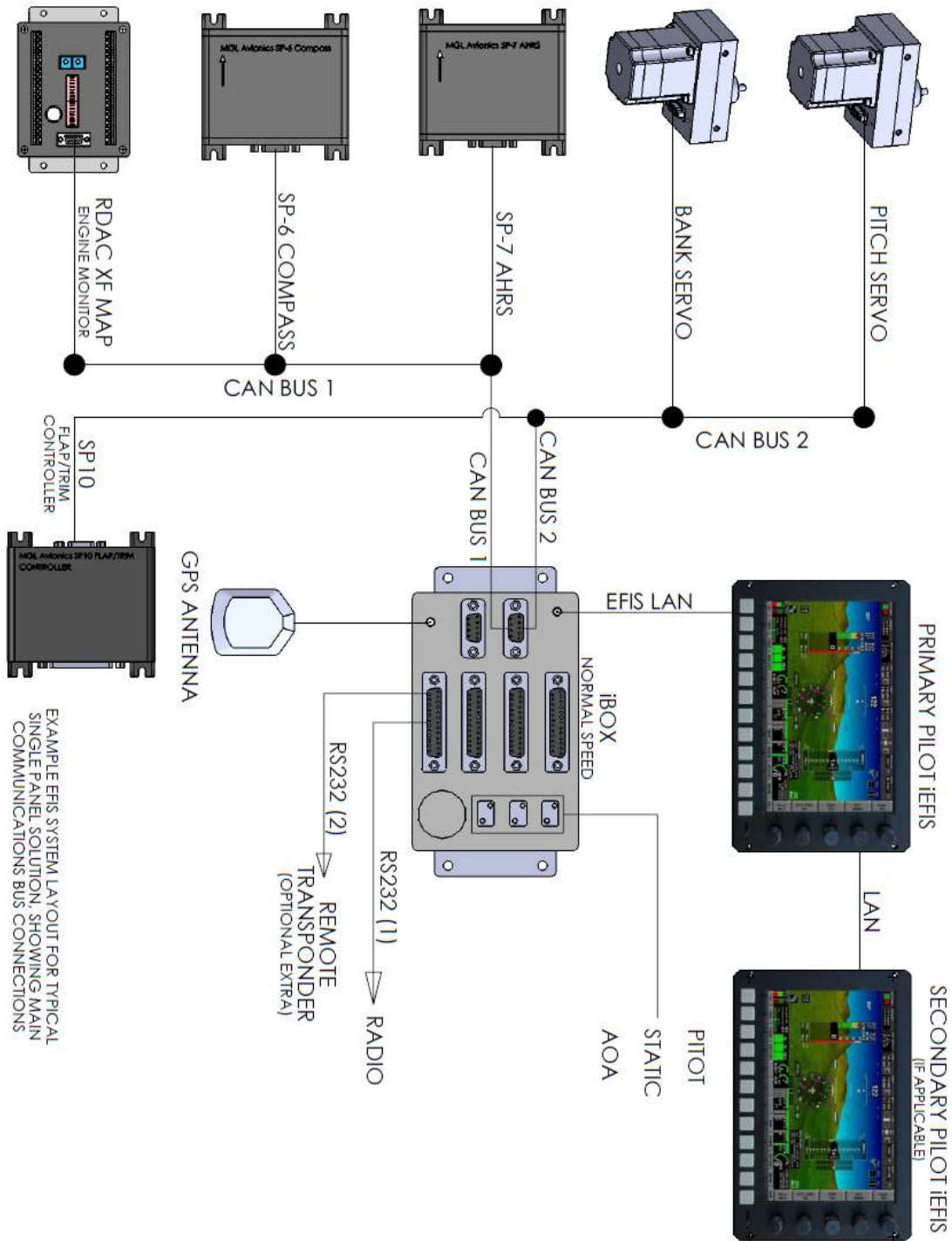

Figure 88: EFIS system / communications bus layout – 914 UL / 912 ULS.

13.11 AHRS AND COMPASS WIRING DIAGRAM

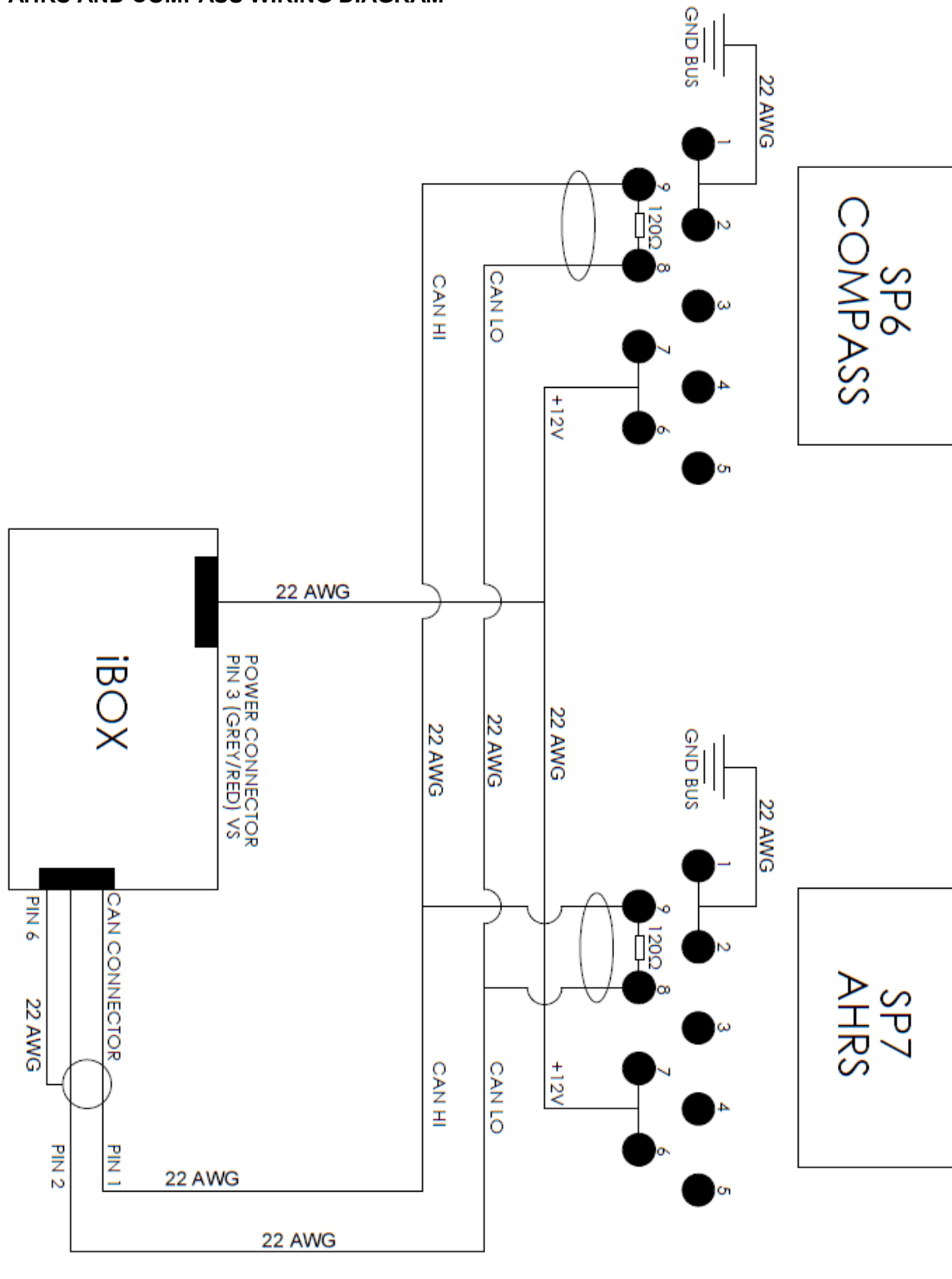

Figure 89: AHRS and compass wiring diagram.

### 13.12 AUTOPILOT ROLL SERVO AND PITCH SERVO WIRING DIAGRAM

NOTE  
PIN 6 + 7 ON THE SERVOS ARE INTERNALLY CONNECTED  
USE EITHER OR BOTH PINS AS POSITIVE

NOTE  
A 120Ω LOAD RESISTOR MUST BE INSTALLED BETWEEN  
PIN 8 + 9 ON EACH SERVO

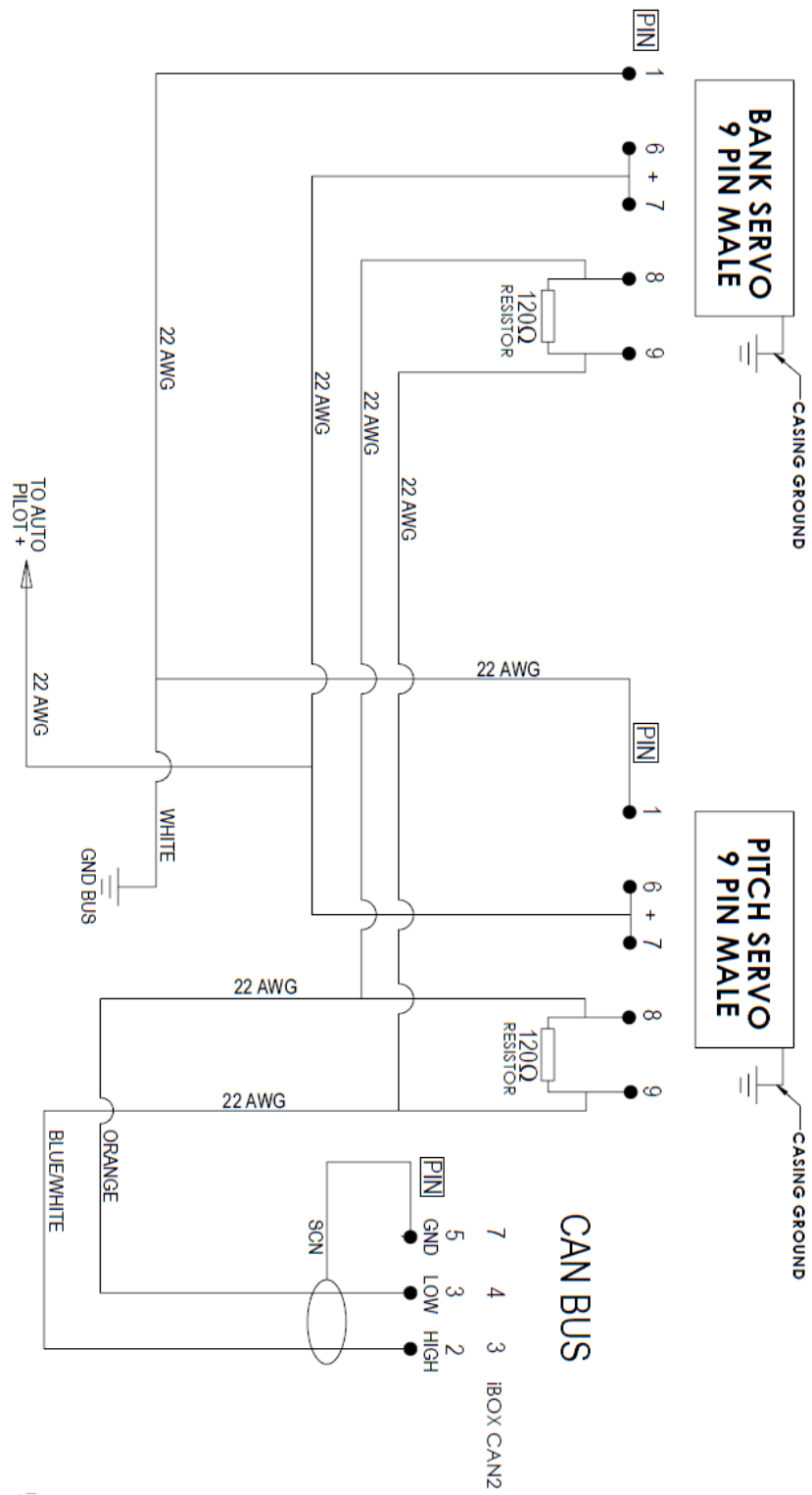

Figure 90: Autopilot roll servo and pitch servo wiring diagram.

13.13 EFIS BACK-UP BATTERY CHARGE CIRCUIT

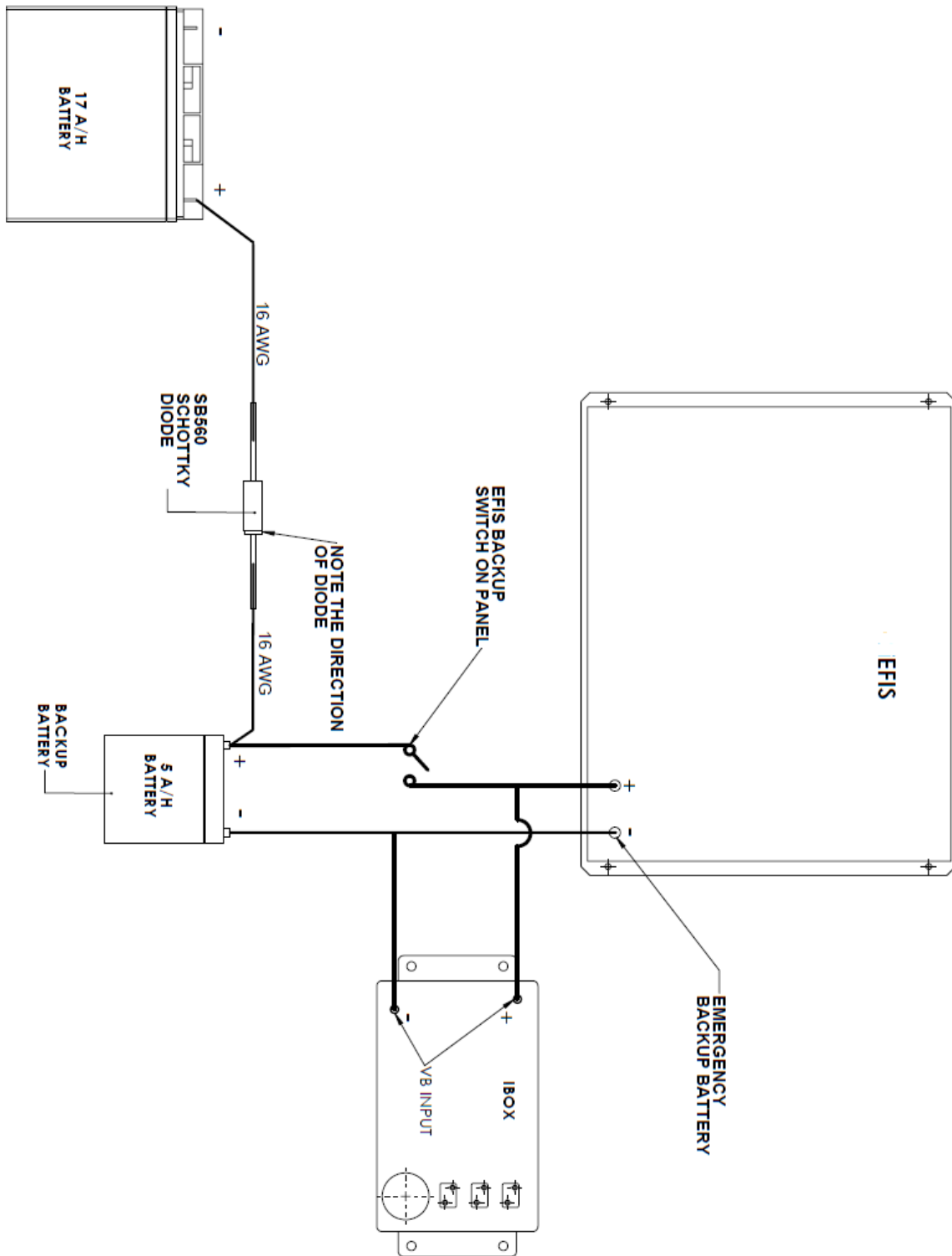

Figure 91: EFIS back-up battery charge circuit.

13.14 HEADPHONE / RADIO WIRING DIAGRAM (MGL V6)

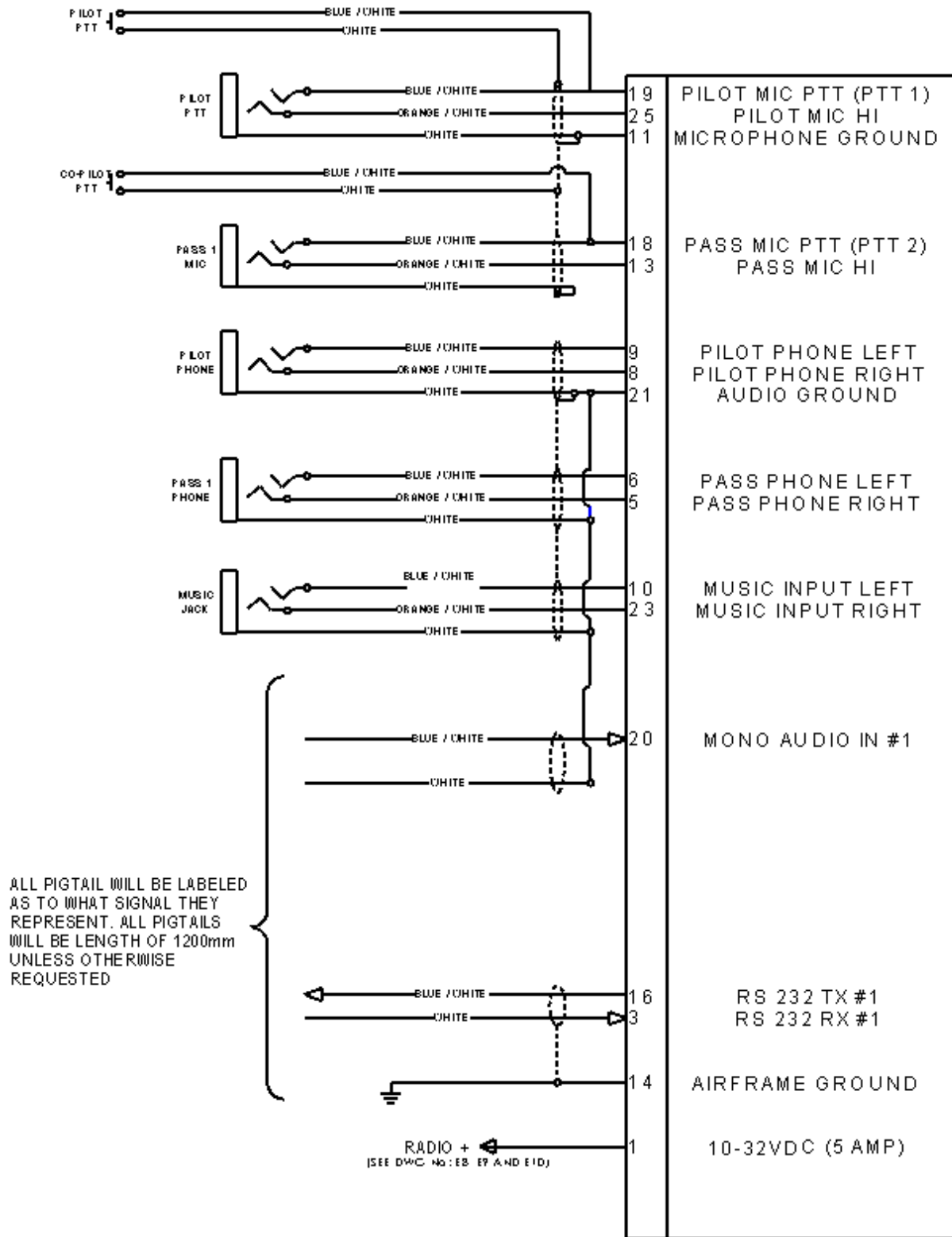

Figure 92: Headphone / radio / intercom wiring diagram (MGL V6).



**13.15 MGL V6 RADIO CONNECTOR PIN DIAGRAM**

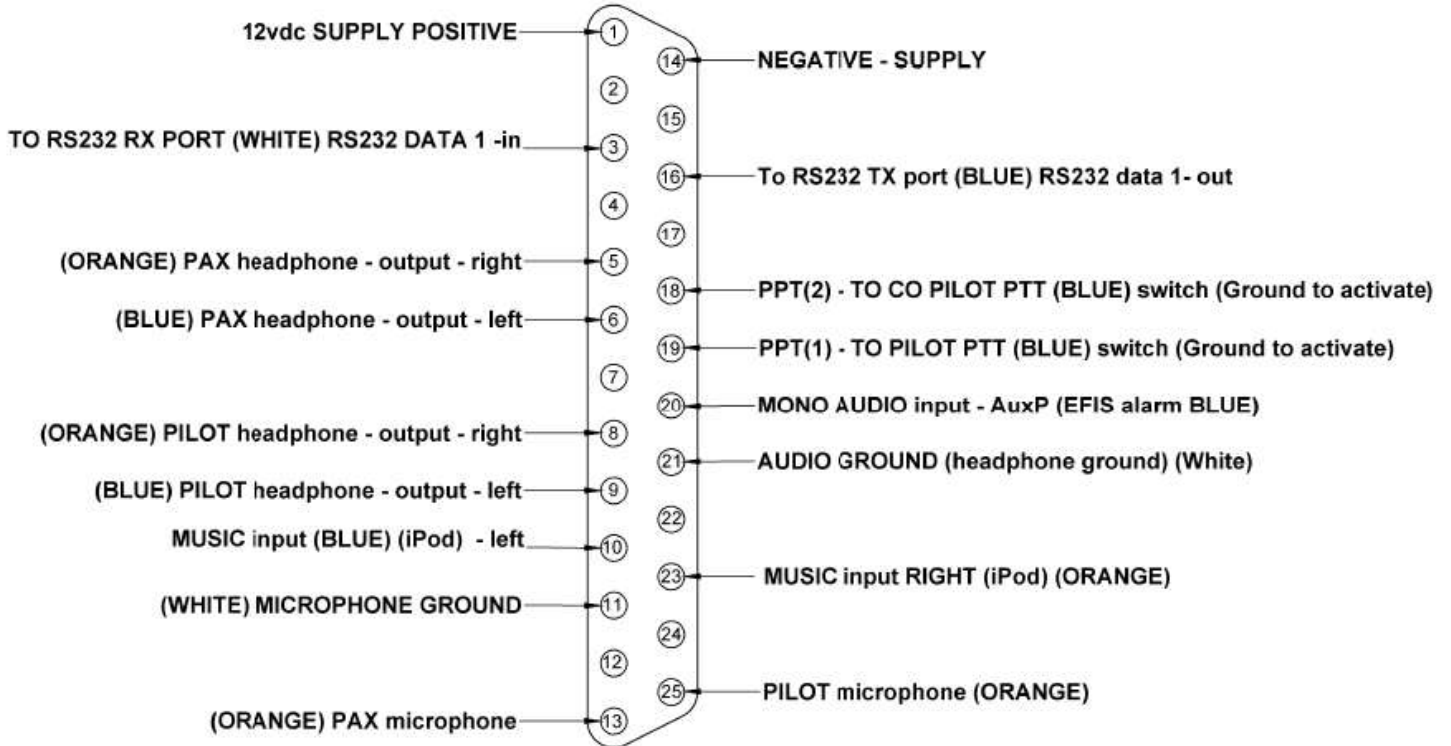

Figure 93: MGL V6 radio connector pin diagram.

13.16 POSITION / NAVIGATION LIGHTS WIRING DIAGRAM

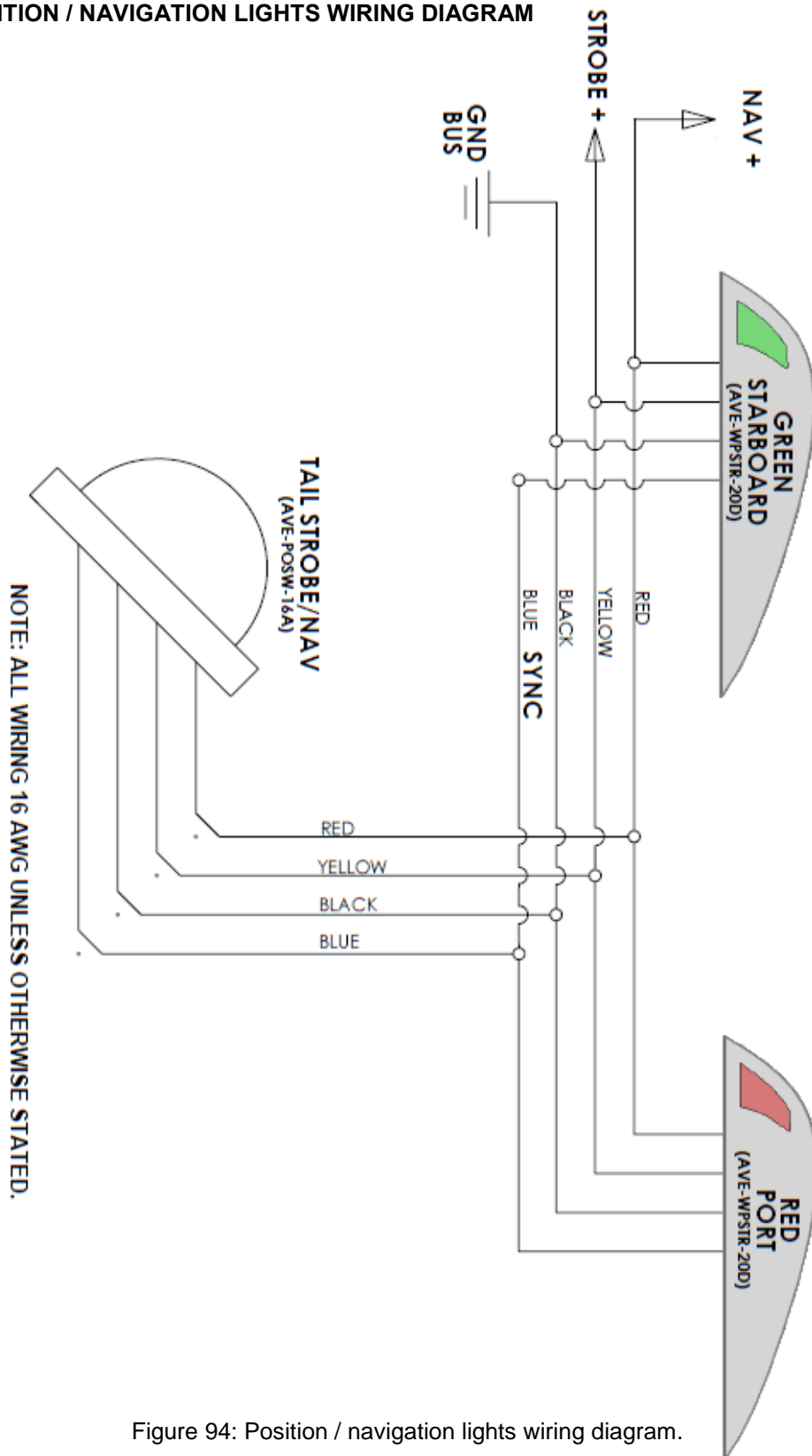

Figure 94: Position / navigation lights wiring diagram.

13.17 OIL PRESSURE TRANSDUCER TO RDAC WIRING DIAGRAM (914 UL / 912 ULS)

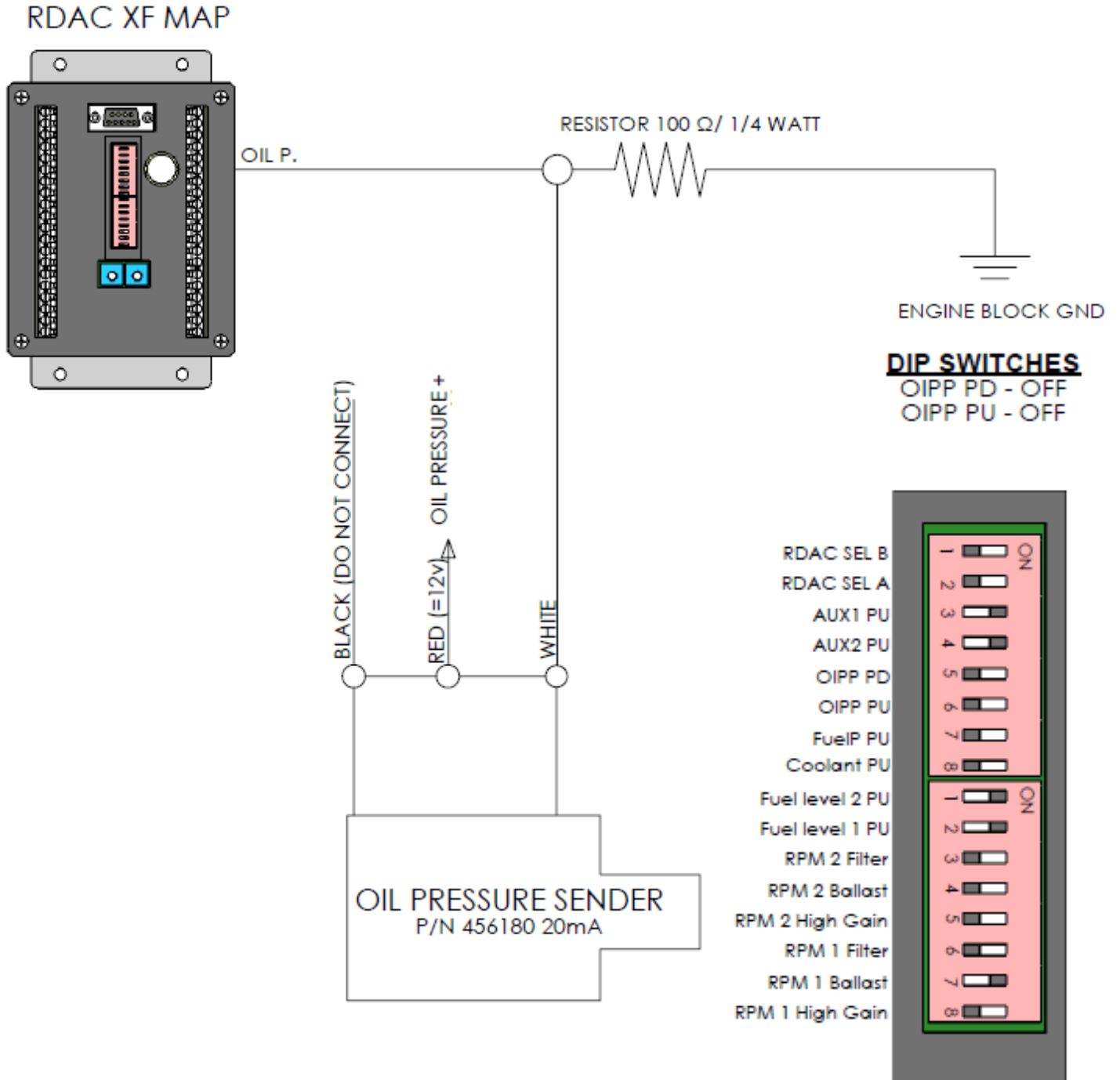

Figure 95: RDAC to oil pressure transducer wiring diagram and settings (914 UL / 912 ULS).

### 3.1 DUAL EFIS INSTALLATION WIRING DIAGRAM

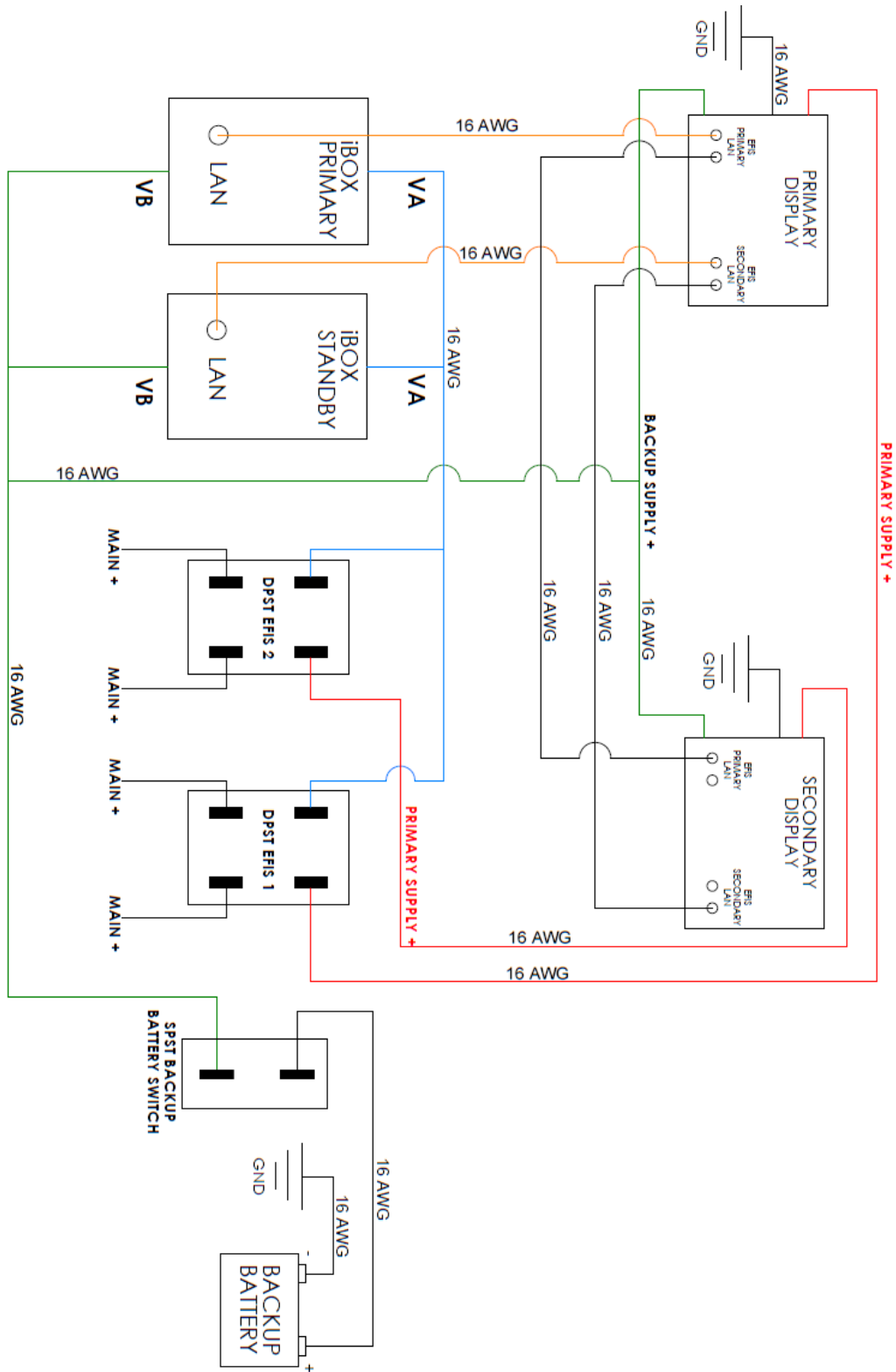

Figure 96: Dual EFIS installation wiring diagram.

### 3.2 TRANSPONDER (IF FITTED) WIRING DIAGRAMS

#### 3.2.1 TRIG TT21 TRANSPONDER (IF FITTED) WIRING DIAGRAM

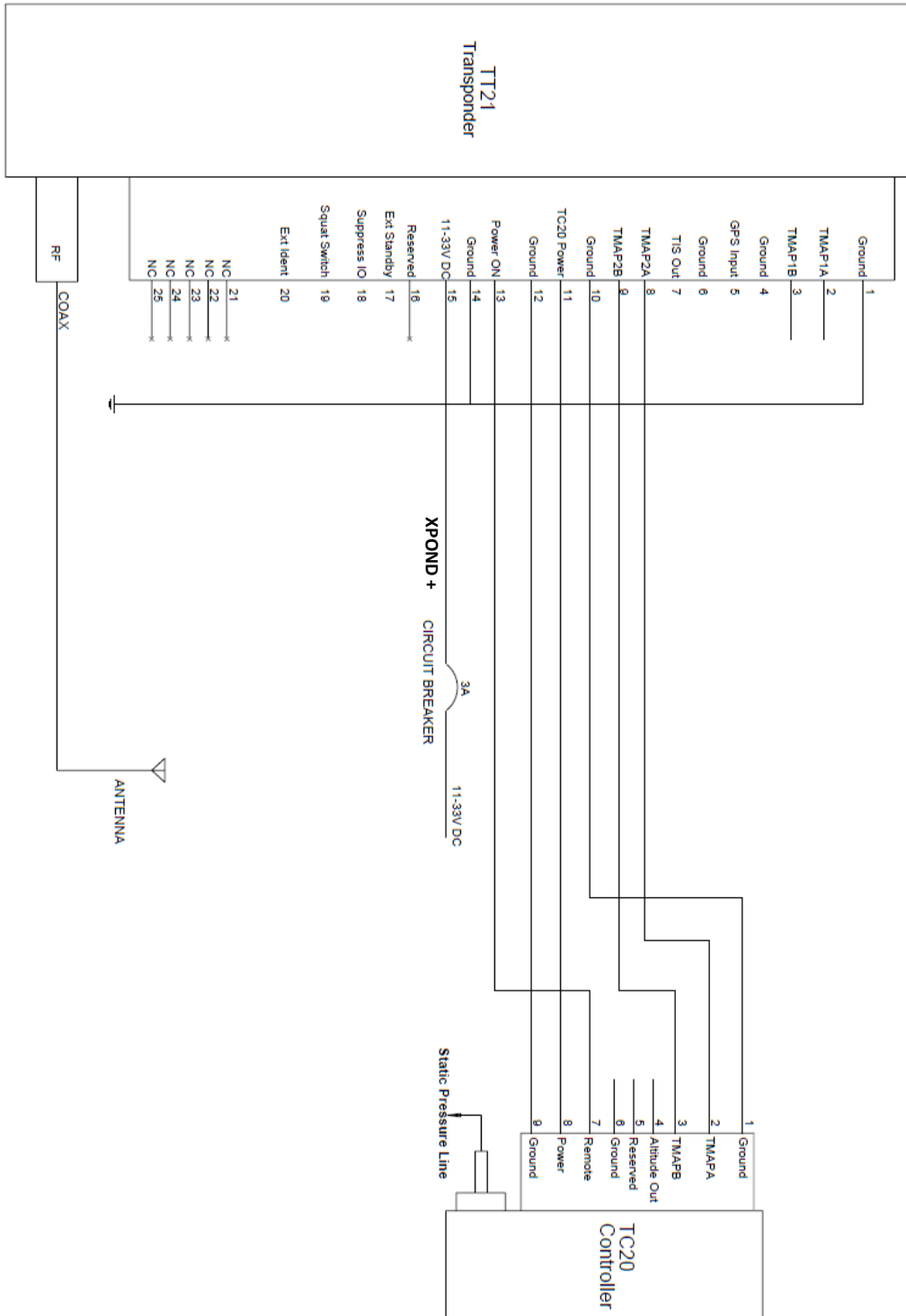

Figure 97: TRIG TT21 transponder (if fitted) wiring diagram.

3.1.1 SANDIA STX 165R TRANSPONDER (IF FITTED) WIRING DIAGRAM

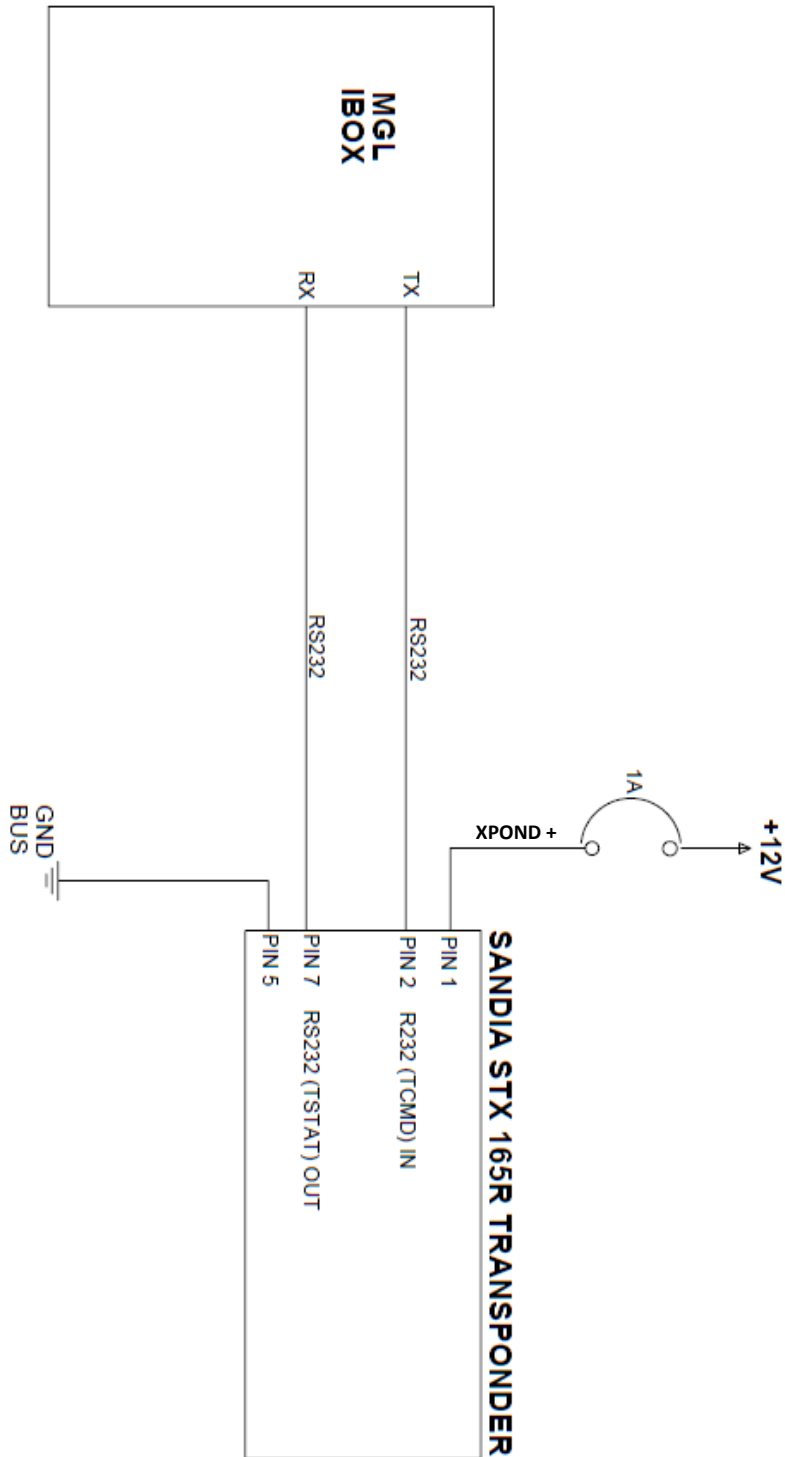

Figure 98: SANDIA STX 165R transponder (if fitted) wiring diagram.

### **3.2 ENGINE MONITORING TRANSDUCERS (SENSORS) / RDAC ELECTRICAL WIRING**

Refer to the latest revision of the RDAC XF installation documentation from MGL (manufacturer).

Also refer to paragraph 13.17.

### **3.3 EFIS AND IBOX ELECTRICAL WIRING**

Refer to the iEFIS Panel Installation Manual and the MGL Avionics iBOX V1 Installation Manual.

### **3.4 PROPELLER AND PROPELLER CONTROLLER ELECTRICAL WIRING INFORMATION (AIRMASTER PROPELLER)**

Refer to the latest revision of the Airmaster AP3 Series and AP4 Series Constant Speed Propeller Operator's Manual.

### **3.5 ROTAX 912 ULS / 912 IS / 914 UL ENGINE ELECTRICAL WIRING INFORMATION**

Refer to the latest revisions of the following Rotax documents, as applicable:

1. Maintenance Manual (Heavy Maintenance) for Rotax Engine Types Rotax 912 and Rotax 914 Series (Reference no. MMH-914).
2. Maintenance Manual (Line Maintenance) for Rotax Engine Type 914 Series.
3. Operators Manual for Rotax Engine Type 914 Series (Reference no. OM-914).
4. Installation Manual for Rotax Engine Type 914 Series (Reference no, IM-914).
5. Maintenance Manual (Line Maintenance) for Rotax Engine Type 912 Series.
6. Operators Manual for Rotax Engine Type 912 Series (Reference no. OM-912).
7. Installation Manual for Rotax Engine Type 912 Series (Reference no. IM-912).
8. Maintenance Manual (Heavy Maintenance) for Rotax Engine Types Rotax 912 i Series (Reference no. MMH-912i).
9. Maintenance Manual (Line Maintenance) for Rotax Engine Type 912i Series (Reference no. MML-912i).
10. Operators Manual for Rotax Engine Type 912 i Series (Reference no. OM-912i).
11. Installation Manual for Rotax Engine Type 912i Series (Reference no, IM-912i).

#### 4. APPENDIX B (FIREWALL MOUNTED EQUIPMENT)

##### 4.1 ROTAX 914 UL

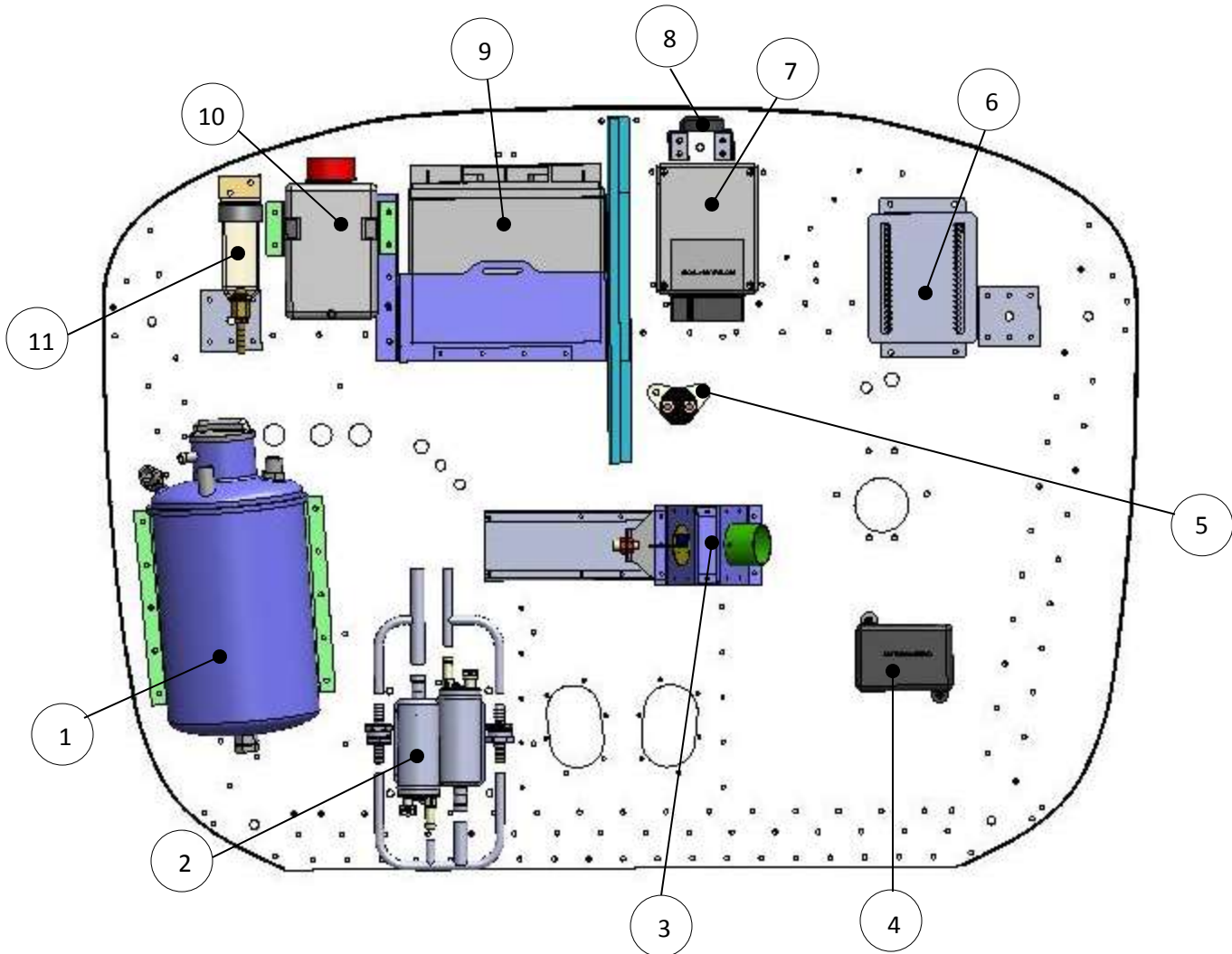

1	Oil reservoir	7	TCU (Turbocharger Control Unit)
2	Fuel pump assembly	8	GPS antenna
3	Cabin air inlet / splitter box	9	Main battery
4	Turbocharger waste gate servo	10	Coolant overflow bottle
5	Starter relay	11	Brake fluid reservoir
6	RDAC		

Figure 99: Firewall forward mounted equipment (914 UL).



4.2 ROTAX 912 IS

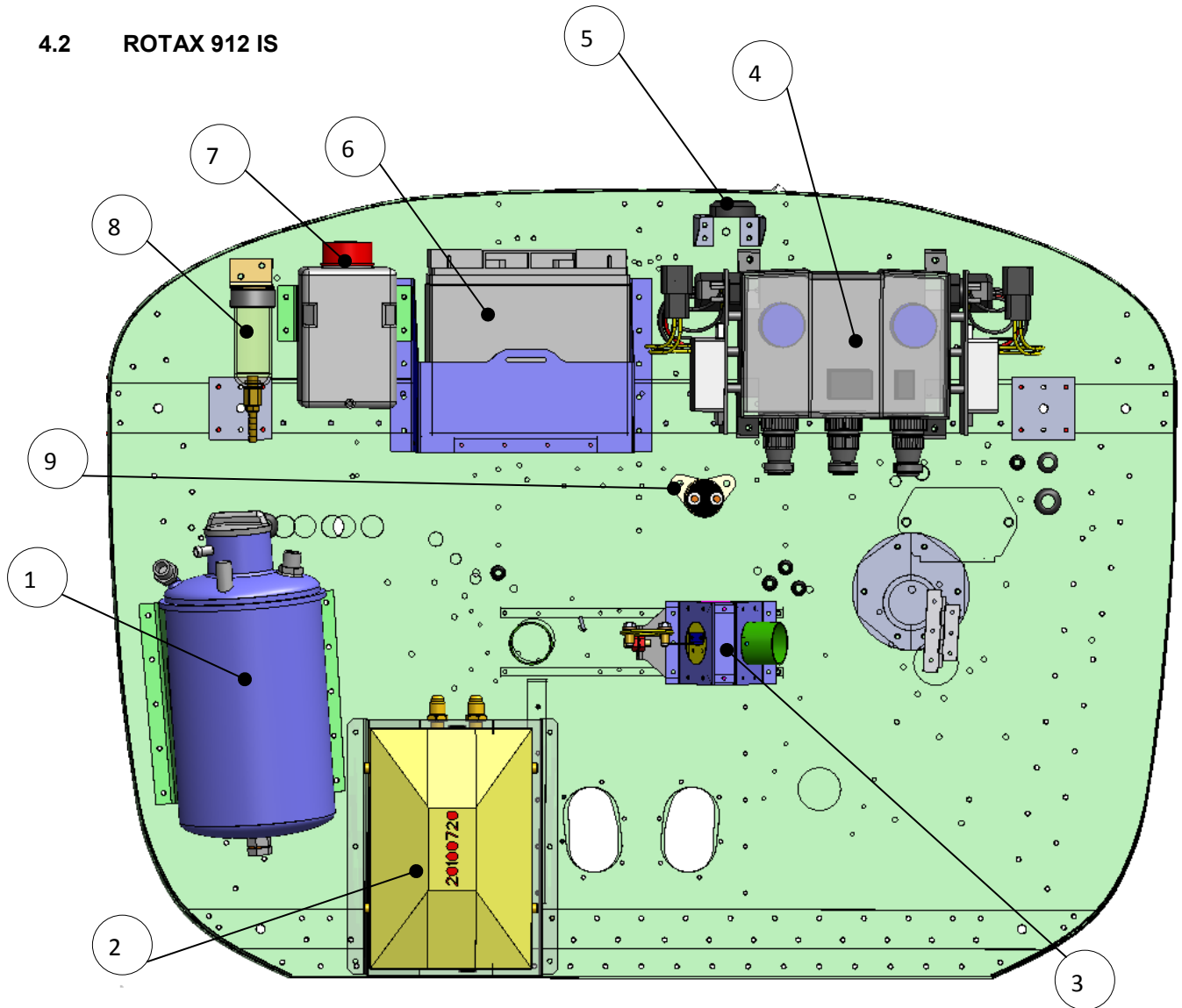

1	Oil reservoir	7	Coolant overflow bottle
2	Fuel pump assembly	8	Brake fluid reservoir
3	Cabin air inlet / splitter box	9	Starter relay
4	Fuse box		
5	GPS antenna		
6	Main battery		

Figure 100: Firewall forward mounted equipment (912 IS).

4.3 ROTAX 912 ULS

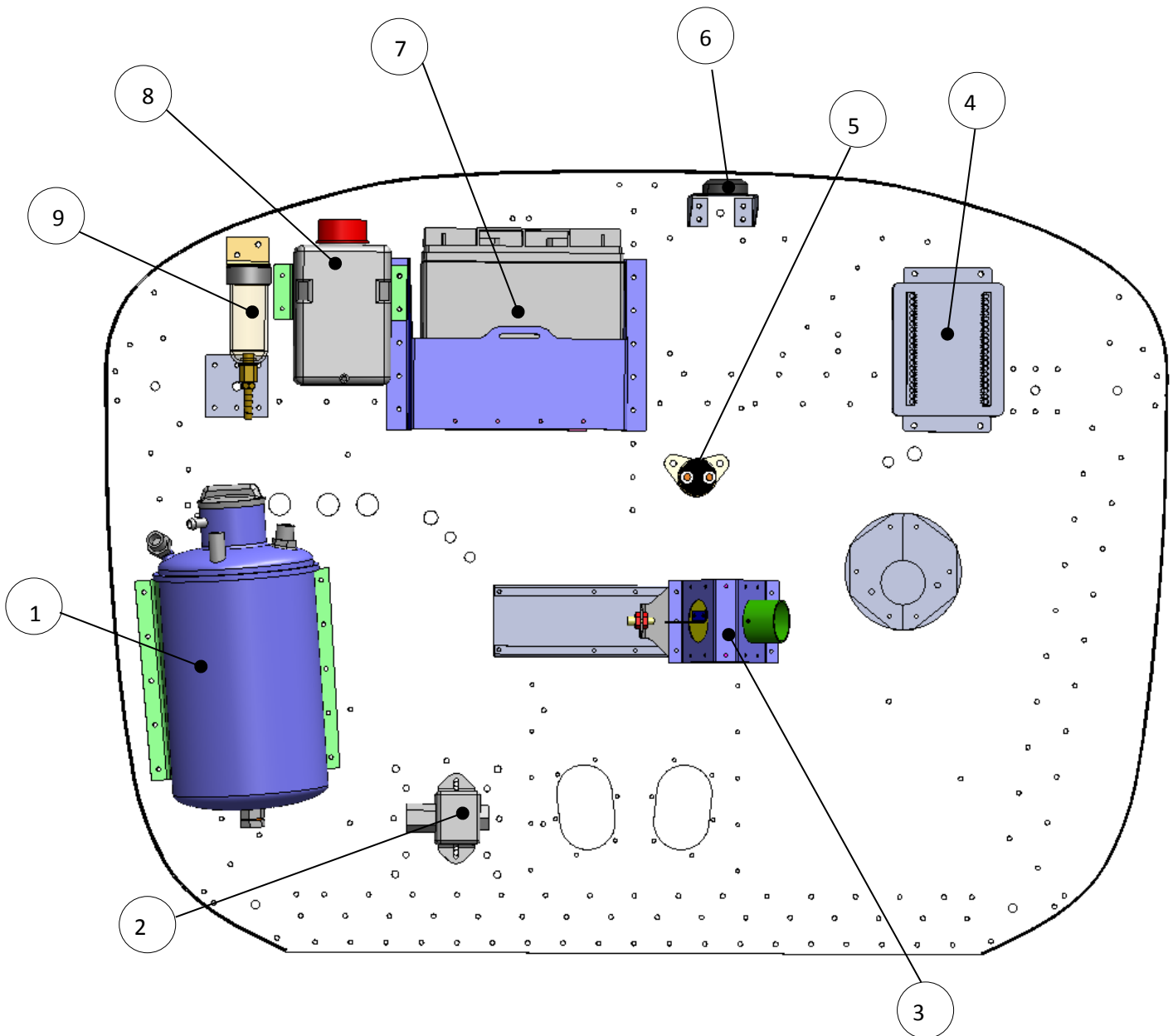

1	Oil reservoir	7	Main battery
2	Electric fuel pump (shown without cover)	8	Coolant overflow bottle
3	Cabin air inlet / splitter box	9	Brake fluid reservoir
4	RDAC		
5	Starter relay		
6	GPS antenna		

Figure 101: Firewall forward mounted equipment (912 ULS).

5. APPENDIX C (GENERAL PROCEDURES AND TECHNIQUES NOT DESCRIBED ELSEWHERE)

5.1 REMOVAL OF TWO-EAR CLAMPS



Use a hacksaw or Dremel tool to cut through the one ear as shown by the dotted line. Once cut through, pry the clamp open and remove.

Figure 102: Two-ear clamp removal.

5.2 PUSHROD ADJUSTMENT

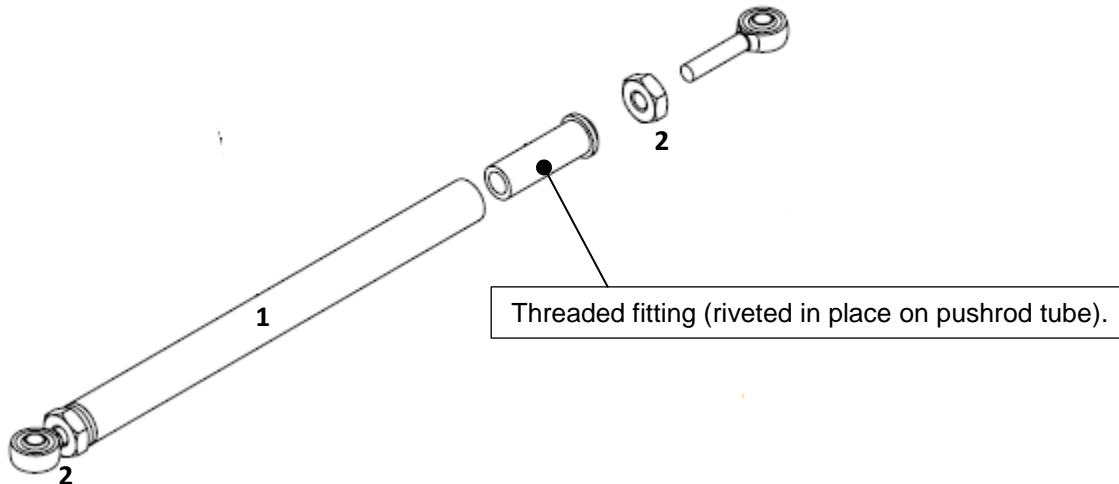

Figure 103: Pushrod adjustment.

Pushrods are assembled using one left handed thread fitting and one right handed thread fitting, allowing the coupling length to be adjusted in situ by turning the rod (1) just as one would a turnbuckle. Loosen the two lock-nuts (2) and adjust the pushrod. Once the desired length has been set the pushrod is locked by tightening the two nuts (2) against the pushrod ends. Do not over tighten the nuts. It is normal procedure to index (i.e. paint creep marks across) the lock-nut and pushrod interfaces.

### 5.3 FITTING OF FIRE RESISTANT SLEEVING OVER OIL AND FUEL LINES / HOSES

Fire resistant sleeving fitted over fuel / oil hoses which are secured (to fittings / couplings) with two-ear clamps must be secured with safety wire adjacent to the two-ear clamp, on both sides of the clamp.

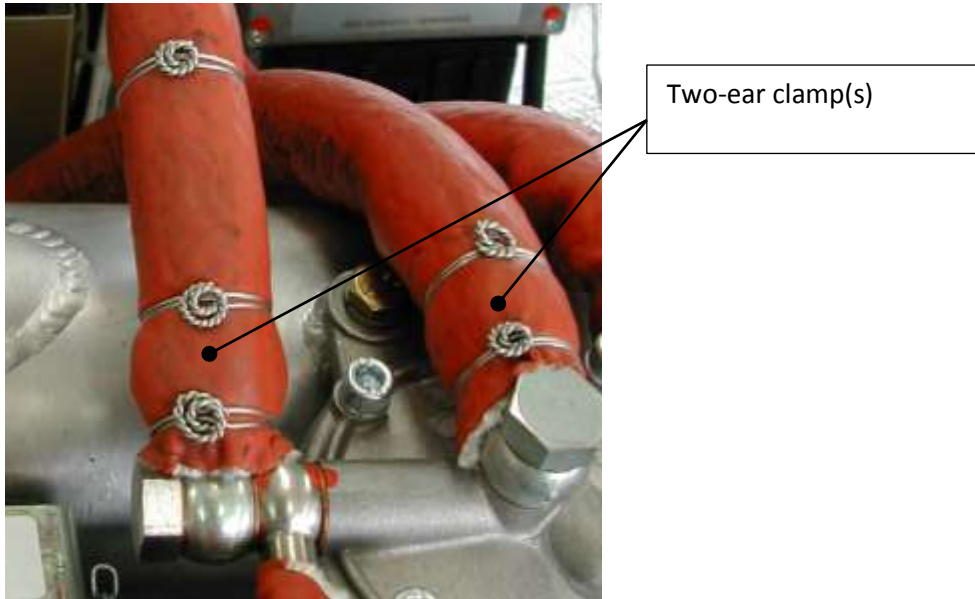

Figure 104: Fire resistant sleeving installation.

**6. APPENDIX D (GENERAL PROCEDURES FOR PREPARATION FOR TRIAL RUN OF ENGINE)**

**WARNING**

**PRIOR TO STARTING THE ENGINE REVIEW ALL INSTRUCTIONS IN THE LATEST REVISION ENGINE OPERATORS MANUAL AND IN ANY LATEST REVISION SERVICE INSTRUCTION APPLICABLE TO THE ENGINE.**

The procedure described below is given as general information and guideline only, and is subject to the information contained in the latest revisions of any applicable documentation and service instructions from the engine manufacturer.

1. Review all applicable instructions and procedures in the latest revision of the applicable operators manual for the engine type.
2. Review any applicable latest revision service instructions for the engine type.
3. Perform a thorough visual inspection of the engine and accessories.
4. Verify engine fluid (fuel, oil and coolant) levels.
5. Verify for correct oil system purging.
6. Verify security of attachment of oil filter.
7. Inspect for correct routing, connection and security of fluid (oil, fuel and coolant) hose / pipe connections.
8. Inspect for leaks.
9. Operate the (electric) fuel pumps and inspect for leaks.
10. Verify that the throttle and choke (912 ULS, 914 UL) operates across the correct range of motion.
11. Verify security of attachment and correct pitch of propeller.
12. If applicable, verify correct operation of propeller and propeller controller.
13. Verify all electrical and sensor wires for correct routing, connection and security.
14. Verify that all applicable instruments are connected correctly and serviceable.
15. Fasten the aircraft to the ground / use chock for wheels. Run the engine in an area which will not expose others to hazards.
16. Verify (use a multimeter / ohmmeter) that the ignition leads are grounding with the ignition switches in OFF position.
17. Inspect the engine mount / mounting / suspension for security attachment and correctness.
18. Verify that no tools, loose or foreign objects remain in the engine compartment.

**7. APPENDIX E (AN WASHER AND NUT HARDWARE DESIGNATIONS)**

Reference (this manual)	Hardware Designation
<b>WASHERS</b>	
AN3 washer (1.6 mm / 0.064")	AN960-10
AN3 washer (0.8 mm / 0.032")	AN960-10L
AN4 washer (1.6 mm / 0.064")	AN960-416
AN4 washer (0.8 mm / 0.032")	AN960-416L
AN5 washer (1.6 mm / 0.064")	AN960-516
AN5 washer (0.8 mm / 0.032")	AN960-516L
AN6 washer (1.6 mm / 0.064")	AN960-616
AN6 washer (0.8 mm / 0.032")	AN960-616L
<b>NUTS / LOCKNUTS</b>	
AN3 lock-nut (Nyloc)	AN365-1032A
AN4 lock-nut (Nyloc)	AN365-428A
AN4 lock-nut (low profile) (Nyloc)	AN364-428A
AN5 lock-nut (Nyloc)	AN365-524A
AN5 castle nut	AN310-5
AN6 lock-nut (Nyloc)	AN365-624A